

Wireless Power Transfer for Medical Implants

Khem Narayan Poudel*, Madhav Pant†

* Computational Science Program, Middle Tennessee State University Murfreesboro, USA, Email: *knp4k@mtmail.mtsu.edu

† Faculty of Engineering and Information Technology, University of Technology Sydney, Australia

Abstract—Wireless power transfer has enhanced its capability and been able to suit itself for various applications with pace of time. This paper presents modern wireless power transfer methods in medical implants design that can possibly overcome the traditional battery operated implants. Various advantages of far field inductive power transfer is pointed and the way to model the implants inside the human body is clearly illustrated. The modelling of maximum power utilization by the implant inside the human body is demonstrated using the equivalent cylinder layers properties. Advanced Design System, a automation software for RF, microwave is used to match the source and load impedance, Simplorer to calculate the voltage utilized by the implant and ANSYS HFSS to model implant in real environment is used to simulate overall project design. This designed implant can drive the implant consuming power up-to 0.1135 mW. The qualitative design and analysis of such implant could also be used on other medical applications considering ICNIRP criteria.

I. INTRODUCTION

Wireless power transfer (WPT) technology for implantable medical devices have been drawing strong research attention due to its safety and design requirements. These safe and relentless wireless power delivery eliminates the need of implantable batteries and percutaneous wires [1], [2]. The percutaneous wires are prone to infection where as the batteries have limited operating time and energy budget. However, the costly and unreliable packaged batteries that required frequent surgery for replacement has been used in some implantable devices like spinal cord stimulators, artificial heart pumps ventricular assist device retinal, and bionic eye brain and many others implantable medical devices. To overcome these issues, wireless power transfer technologies can be used to charge the batteries driving the implants or drive implants independently. Different types of well known wireless power transfer have been used such as near field inductive power transfer, optical power transfer, ultrasonic power transfer and far field inductive power transfer depending upon their characteristics and their application criteria. Various experiments have been carried out to enhance the intensity of power to be transfer to the destination device over long distance in medical application [3]. In this paper, we present a far field inductive power transfer method that can penetrate at higher depth, and the field at the destination can be controlled by adjusting the frequency and power of the transmitter to meet ICNIRP criteria.

II. MODEL DESCRIPTION

Figure 1 illustrates the general setup for far field power transfer technique. It consists of transmitter which radiates at 2.5 GHz through half-wave length dipole antenna of length

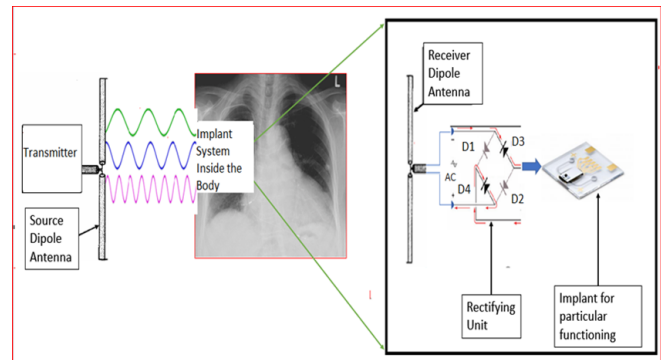

Fig. 1. The general layout setup for wireless power transfer for medical implants.

60 mm and of diameter 5 mm. The dipole antenna along with rectifier and implant is wrapped with the ceramic surface of width 3 mm. The antenna is kept at 5 mm below the skin and 5 mm underneath the bone. The receiving implant system was kept inside the geometrical cylinders which was modelled with characteristics of bone and skin. Both the antennas are separated at the various distance from their centers. The power source antenna is excited using lumped port.

III. RESULTS AND DISCUSSION

The central distance between the power transmitting antenna and the power receiving antenna are varied and the field captured on the receiving antenna is recorded using ANSYS HFSS which is high frequency structure simulator software. To capture the real maximum voltage received by the implant inside the human body cylinder layers with similar characteristics of bones and skin was modelled. The field generated on the receiving antenna due transmitting antenna was recorded and mathematical calculation was made to calculate power density. Product of power density along with surface area gave rise to power on the receiving antenna. Thus, received power was replaced with the power source in ANSYS simplorer along with arranged rectifier to calculate the maximum voltage utilized by the implant. The receiving implant system was kept inside the geometrical cylinders which was modelled with characteristics of bone and skin. Both the antennas as separated at the various distance from their centers. The power source antenna is excited using lumped port.

TABLE I
FIELDS ON THE VARIOUS SURFACE AT 180 MM DISTANCE APART FROM
THE CENTRES OF THE ANTENNAS

Surfaces	E_{Max} (V/m)	E_{Avg} (V/m)	H^*_{Max} (A/m)	H^*_{Max} (A/m)
On the Skin	27.19	20.65	0.25	0.19
On the bone	29.75	17.95	0.77	0.33
On the Ceramic Coating	35.95	18.11	0.63	0.33
On the receiving antenna	92.31	44.81	1.15	0.52

Table shows the electric and magnetic field generated on the various portion of the implant system inside the human body. The power density (W/m^2) is calculated by real value of product of electric field(E) and conjugate of magnetic field (H^*). At distance of 180 mm the 27.19 V/m, 29.75 V/m, 35.95 V/m, 92.31 V/m was developed on the surface of skin, bone, ceramic coating and on receiving antenna which lies below the 137 V/m which is below the Occupational exposure limit set by ICNIRP criteria for public exposure. The effective area of the antenna considering the lumped port of length 2 mm was $4.241 \times 10^{-5} m^2$. The power density multiplied with the surface area of the antenna gives the value of power (P) developed at the power receiving antenna.

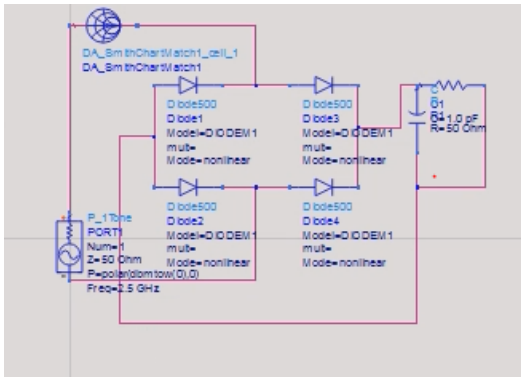

Fig. 2. Smith Chart matching for Maximum power transfer.

For maximum power transfer impedance of the transmitting antenna should be matched with impedance of the receiving antenna with rectifier circuit. We tested this impedance matching using smith chart in Advanced Design System, which is automation software for electronic design. We assume that load is of 50 ohm and capacitor of 10 pF for smoothing of DC voltage. Figure 4 illustrates the auto element matching of series inductance of $L1 = 797.54 \mu H$ and shunt capacitor of $C2 = 10 \text{ pF}$. Figure 3 demonstrates the response of the network after selecting the matched element which resembles with the power transmitting antenna.

Figure 4 shows the simulation rectifier circuit for Simplorer that is developed after extracting elements for matched networks along with HSMS 27202 diode. The power developed at the surface of the antenna is substituted with power source of respective value and simulation was carried which resulted the corresponding maximum voltage that can be utilized by the implant of resistance 50 Ohm. We found the power of 25.2764, 4.3797, 4.4942, and 0.98 milliwatt

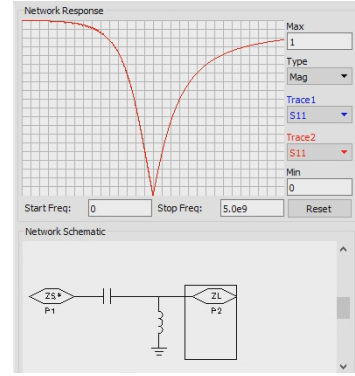

Fig. 3. Network response of the designed rectifier circuit.

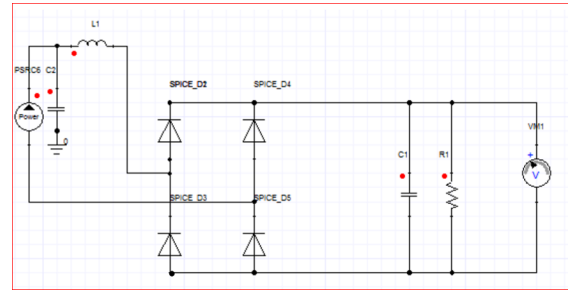

Fig. 4. Rectifier circuit for simulation in Simplorer.

developed at the surface antenna at distances of 100, 150, 180, and 208 mm respectively. Similarly, the maximum voltage of 655.71, 219.7353, 223.55, 75.34 developed at the rectifier circuit due to corresponding power source at their respective distances.

IV. CONCLUSION

In this paper, we presented the design of rectenna that can be useful for powering various medical implants. We analyzed the implant system triggered by dipole antenna wrapped by ceramic layer is placed inside the cylinder designed with characteristics of human skin and bone using ANSYS HFSS. The power received on the antenna used to extract the maximum voltage inside the human body using Simplorer. The simulation experiment is carried out to verify the ICNIRP criteria for equivalent human characteristics. In depth design analysis and modeling of such implants will enable future efficient integrable wireless power transfer technology.

REFERENCES

- [1] K. Agarwal, R. Jegadeesan, Y. Guo, and N. V. Thakor, "Wireless power transfer strategies for implantable bioelectronics," *IEEE Reviews in Biomedical Engineering*, vol. 10, pp. 136–161, 2017.
- [2] K. N. Poudel and W. M. Robertson, "Maximum length sequence dielectric multilayer reflector," *OSA Continuum*, vol. 1, no. 2, pp. 358–372, Oct 2018.
- [3] F. Gong, Z. Wei, Y. Cong, H. Chi, B. Yin, and M. Sun, "Analysis of sar distribution in human head of antenna used in wireless power transfer based on magnetic resonance," *Technology and Health Care*, no. 25, p. S387S397, 2017.