

A Miniaturized 3 Dimensional Bandpass Frequency Selective Surface

T. Whittaker¹, Y.Vardaxoglou²

Wolfson School of Mechanical, Electrical and Manufacturing Engineering
Loughborough University
Loughborough, UK

¹ T.Whittaker@lboro.ac.uk, ² J.C.Vardaxoglou@lboro.ac.uk

Abstract—A planar bandpass frequency selective surface (FSS) is proposed along with an alternative 3D element design with the intent of miniaturizing the unit cell. The two structures are simulated in CST and compared. Such techniques show the potential of using 3D elements in FSS design to miniaturize the structure for space constrained applications.

Keywords— Additive Manufacturing, FSS, Bandpass, Filter, Meta-atom, Metamaterial

I. INTRODUCTION

Frequency selective surfaces (FSS) have conventionally been planar structures. However with additive manufacturing, FSSs using 3D elements can now be readily realized. With this increased design freedom, designers can produce more complex, compact and customizable structures than previously possible with planar elements. Using 3D elements in FSS design can have some key advantages; for example miniaturization [1], [2] and an increased stability to variations in the angle of incidence [3]–[5]. Miniaturization is of particular interest here as this can overcome the challenges presented by space constrained applications. Example applications for 3D FSSs would be for low cost, 3D printable filters or diplexers.

This paper presents a planar 3-layer bandpass FSS and illustrates the attempt to miniaturize the unit cell by utilizing 3D elements. The structures will be simulated in CST and the results compared. The 3D element FSS will also be designed in mind to be printable with currently available multi-material 3D printers. Previous attempts at miniaturizing an FSS include a ‘four-legged loop’, where the legs of the loop were folded back

upon itself to increase the overall loop length [1]. Another example is the ‘folded dipole’ [2] which follows the same principle of increasing the conductor length by folding the dipole. In this paper alternative techniques will be investigated to miniaturize the elements, such as meandering conductors to increase inductance and increasing surface area for capacitive coupling.

II. PLANAR BANDPASS FILTER

The design of the bandpass FSS is comprised of an array of capacitive elements (square loops), an inductive grid and another array of square loops. The planar elements fit inside a unit cube of lossless PLA Plastic ($\epsilon_r = 3$, $\tan(\delta) = 0$) with a size $10\text{mm} \times 10\text{mm} \times 10\text{mm}$. The FSS is illuminated by a vertically (y-axis) polarized TEM plane wave propagating along the z-axis. The width and height of the square loops perpendicular to the direction of propagation is 8mm with a thickness of 1mm , the depth of the loops are considered to be insignificant. The loops are separated by 6mm , the inductive grid is located in between them with a width of 1mm and an insignificant thickness. The metallisation is also assumed to be lossless. A schematic of the planar FSS is shown in Fig. 1.

III. 3D ELEMENTS

To begin the miniaturization process, the dimensions of unit cell of the FSS were scaled down by a factor of two. This has the effect of ‘stretching’ the frequency response across the frequency scale by a factor of two. The 2D elements are then converted into 3D elements in an attempt to reverse the effects of scaling.

There are three variables in the structure that can be adjusted to change the characteristics of the filter. The first is the separation between the square loops. The second is the length of the inductive grid; the grid can be meandered to increase its length and thus its inductance. The third variable is by increasing the mutual capacitive coupling of the square loop by using additional plates on the top and bottom of the square rings. These variables influence the resonances in the passband of the filter; the inductance of the grid affects the first resonance, the loop spacing affects the second resonance and the size of the capacitive plates affect both resonances.

Through the control of these variables, the frequency response of the 3D element FSS can be made to behave in a similar manner to the planar FSS. This was achieved by meandering the path of the inductive grid to increase the effective length by 8mm , increasing the separation between the

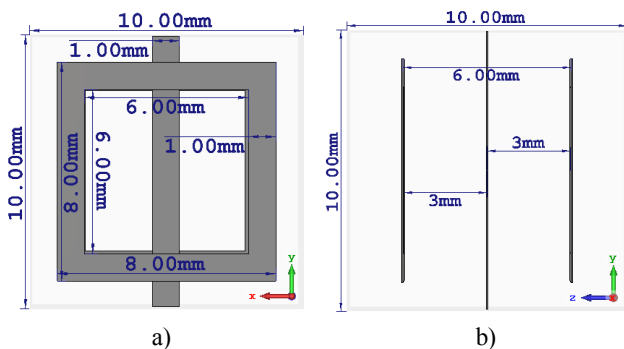

Fig. 1. Drawings of the 3-layer bandpass planar FSS, a) front view and b) side view.

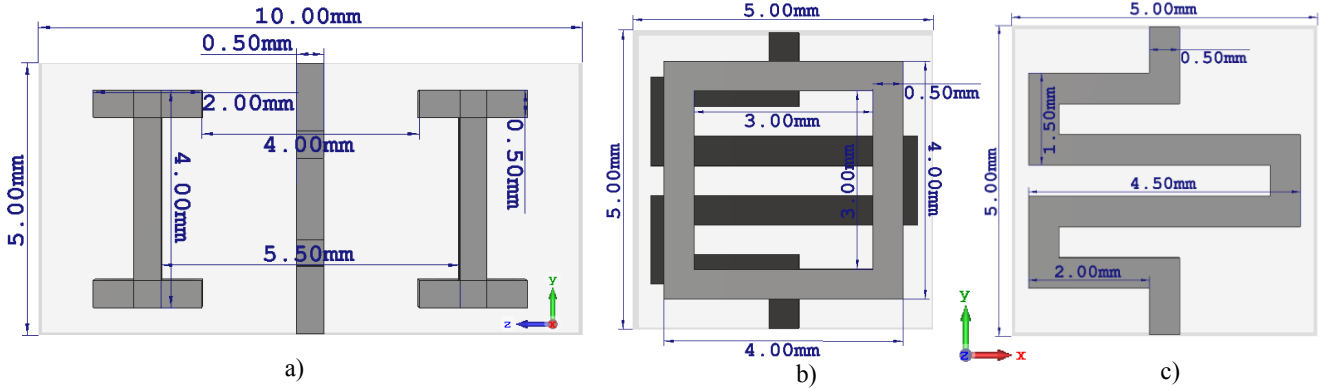

Fig. 2. Drawing showing the dimensions of the 3D element FSS, a) side view, b) front view, c) front view (meandered grid only)

square loops from 3mm to 5.5mm and adding capacitive plates to the square loops with a length of 2mm. The thickness of the conductors will also be increased to 0.5mm, to be compatible for 3D printing. The dimensions of the 3D element FSS is shown in Fig. 2.

The two structures were simulated in CST and the S-parameters are plotted in Fig. 3. As can be seen from the responses the characteristics are quite similar. However, from 6 GHz onward the frequency responses from the two structures deviate. The planar filter has a centre frequency of 3.60 GHz and a -10dB bandwidth 1.75 GHz whilst the 3D element filter has the same centre frequency but a slightly smaller -10dB bandwidth at 1.53GHz. However, this comes at the advantage of a much smaller unit cell; the volume reduction from the original planar FSS to the 3D element FSS is 75%. This infers that the 3D element design is more space efficient than the planar alternative and presents great advantages in terms of miniaturization. From looking at Fig. 2 the space in the unit

cell is still not fully utilized and could be further used to to reduce the position of the filter's centre frequency.

IV. CONCLUSION

In this paper a bandpass planar FSS and its derivative 3D element FSS have been presented. It has been demonstrated that by utilizing 3D elements in FSS design great advantages can be conveyed with regards to miniaturization. In this particular case a unit cell volume reduction of 75% was achieved at the expense of a slight reduction in the -10dB bandwidth. This presents great opportunities for FSS design in miniaturised systems that have limited space requirements. Further work is required to manufacture the proposed structures and to obtain measurements for further comparison. Investigation can also be conducted into the stability of both structures to a changing angle of incidence of incoming waves.

REFERENCES

- [1] E. A. Sanz-Izquierdo, Benito and Parker, "Frequency Selective Surfaces Formed by Partially Metalising 3D Printed Shapes," *9th Eur. Conf. Antennas Propag.*, pp. 1-4, 2015.
- [2] B. Sanz-Izquierdo and E. A. Parker, "3-D Printing of Elements in Frequency Selective Arrays," *IEEE Trans. Antennas Propag.*, vol. 62, no. 12, pp. 6060-6066, Dec. 2014.
- [3] B. Sanz-Izquierdo and E. A. Parker, "3D printed FSS arrays for long wavelength applications," in *The 8th European Conference on Antennas and Propagation (EuCAP 2014)*, 2014, pp. 2382-2386.
- [4] S. N. Azemi, K. Ghorbani, and W. S. T. Rowe, "3D Frequency Selective Surface with incident angle independence," *Microw. Conf. (EuMC)*, 2013 *Eur.*, 2013.
- [5] I. P. Hong and I. G. Lee, "3D frequency selective surface for stable angle of incidence," *Electron. Lett.*, vol. 50, no. 6, pp. 423-424, Mar. 2014.

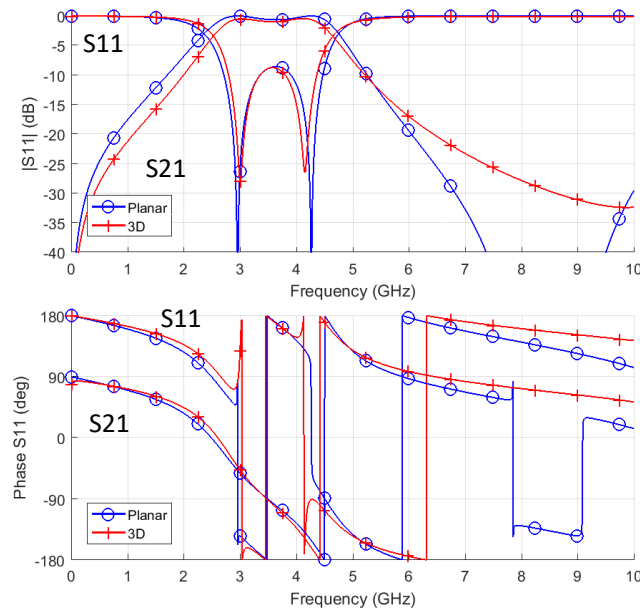

Fig. 3. Comparison of the S-parameters between the original planar FSS and the 3D element FSS.