

Modeling of Planar Inductors in IC's at X-Band

Kevin Idstein*¹, Roberto G. Rojas¹ and Gregory Creech²

¹The Ohio State University, Electrical Engineering, ElectroScience Laboratory
Columbus, OH 43212

²AFRL/SNDM, Wright Patterson AFB, Dayton, OH 45433

Microwave integrated circuits today demand low power dissipation and a high level of integration. To meet these requirements, engineers must design low-loss passive devices on-chip. However, at X-Band frequencies, passive components suffer significantly from skin-effect losses, conductive substrate losses, and field coupling in an inhomogeneous substrate. These parasitic effects cannot be neglected when designing passive components to operate at high frequencies.

To investigate the various models available for IC inductors, six inductors ranging from 0.75 nH to 1.00 nH were designed with an emphasis on maximizing the Q factor. The technology is Fully Depleted Silicon on Insulator (FDSOI) with a silicon resistivity of 2000 Ohm-cm. Figure 1 shows a popular circuit model for this inductor. Unfortunately, there is little consensus from the literature as to how the circuit components of this model are derived. Frequently, these components are found by data fitting the measured or simulated S-Parameters. Data fitting is not beneficial for design purposes, however. There are analytical formulas for these component values, but they do not provide sufficient accuracy.

The inductors were simulated using three simulation tools: a standard full wave Method of Moments (MOM) simulator, a MOM simulator using electrostatic approximations (RF MOM), and a Partial Element Equivalent Circuit (PEEC) simulator using electrostatic approximations. Furthermore, after making some rough approximations of the current distribution and charge distribution, the PEEC technique was also used to analytically calculate the component values of Figure 1. Once the component values were calculated, the Q and effective inductance of the model circuit were calculated. These two parameters are compared to the MOM simulation, the RF MOM simulation, the electrostatic approximate PEEC simulation, and measured data.

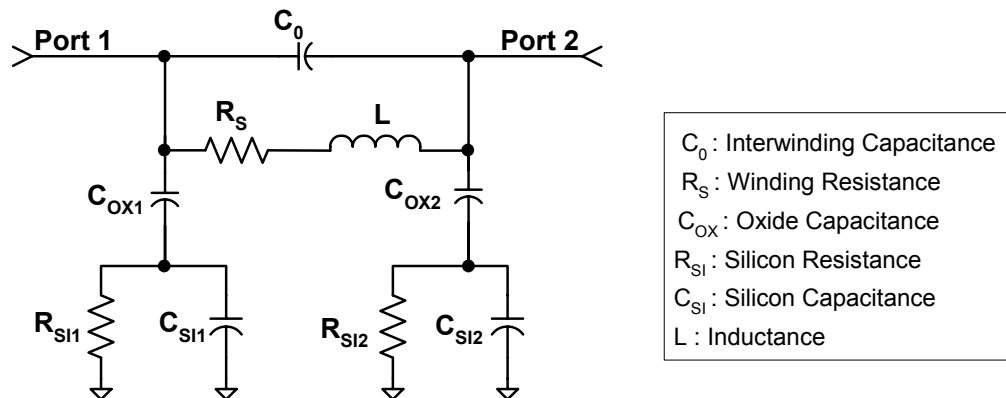

Figure1: Generic circuit model for a spiral inductor on an IC substrate.