

Transmitter with antenna array for MC-CDMA forward link

Yosuke FUJINO Masayuki INADA Yoshihiko KUWAHARA
Faculty of Engineering, Shizuoka University
3-5-1 Johoku Hamamatsu, Shizuoka 432-8561, Japan
e-mail: tykuwab@ipc.shizuoka.ac.jp

1. Introduction

In recent years, the OFDM is attracted attention as the high-speed radio data communication. The OFDM can take advantage of the bandwidth efficiently because of use of orthogonal multi-carriers. And, Inter Symbol Interference (ISI) hardly occurs because of the guard interval. MC-CDMA is known as a method of multiplying the OFDM signals by using CDMA techniques.

Generally, Walsh-Hadamard sequence is exploited in MC-CDMA. Therefore, if Frequency Selective Fading (FSF) didn't occur, received signals don't suffer interference except for users who use the identical sequence. However, FSF occurs in the radio communication environment by multi-path propagation. Then, orthogonality among the sequences is lost by FSF and received signals suffer serious interference from users who exploit different sequences. Such Multiple Access Interference (MAI) can be suppressed by the adaptive antenna[1]. Since number of the interference sources is almost larger than elements in general mobile communication system, it cannot direct nulls to all interference sources and perfect suppression of MAI is not expected.

We propose a new transmitter with the antenna array to solve these problems. This transmitter suppresses FSF and lowers correlation between sequences by combining the subcarriers. In addition, it suppresses residual interference by the antenna array. Antenna array operates effectively since number of interferences with high correlation decreases by combining subcarriers. In this paper, adaptive weights based on MRC (Maximum Rate Combining) and MMSEC (Minimum Mean Square Error Combining) are derived analytically. Then, user capacity of forward link is examined by the numerical simulation.

2. Beamforming Algorithm

The block diagram of the proposed transmitter is shown to Fig.1. We assume that power of signals with large delay beyond the guard interval is sufficiently low and that Doppler shift is sufficiently small compared with interval of subcarriers. Response vector between the base station and k_0 th mobile station is defined as $\mathbf{v}_{k_0,m,n}$. When signals for k_0 $s_{k_0,m,n}$ are transmitted, despread signals received by k_1 th user x_{k_0,k_1} is expressed by next formulas.

$$x_{k_0,k_1} = \sum_{n=1}^N c_{k_1,n}^* \sum_{m=1}^M v_{k_1,m,n} s_{k_0,m,n} = \sum_{n=1}^N c_{k_1,n}^* \sum_{m=1}^M v_{k_1,m,n} d_{k_0} c_{k_0,n} w_{k_0,m,n}^* = d_{k_0} W_{k_0}^H A_{k_0,k_1} \quad (1)$$
$$W_{k_0} = \left(w_{k_0,1,1} \cdots w_{k_0,1,N} \quad w_{k_0,2,1} \cdots w_{k_0,m,n} \cdots w_{k_0,M,N} \right)^T$$

$$A_{k_0, k_1} = \left(c_{k_1, 1}^* c_{k_0, 1} v_{k_1, 1, 1} \cdots c_{k_1, N}^* c_{k_0, N} v_{k_1, 1, N} \quad c_{k_1, 1}^* c_{k_0, 1} v_{k_1, 2, 1} \cdots c_{k_1, n}^* c_{k_0, n} v_{k_1, m, n} \cdots c_{k_1, N}^* c_{k_0, N} v_{k_1, M, N} \right)^T$$

Here, m , n , d_{k_0} , $c_{k_0, n}$ and $w_{k_0, m, n}$ denote number of antenna elements, number of subcarriers, data symbols and spread codes for k_0 th mobile station, and adaptive weight of transmitter, respectively.

2.1 Maximum Ratio Combining (MRC)

Weight vector for MRC can be expressed by next formulas.

$$W_{k_0 \text{ MRC}} = \frac{V_{k_0}}{V_{k_0}^H V_{k_0}} \quad (2)$$

$$V_{k_0} = \left(v_{k_0, 1, 1} \cdots v_{k_0, 1, N} \quad v_{k_0, 2, 1} \cdots v_{k_0, m, n} \cdots v_{k_0, M, N} \right)^T$$

2.2 Minimum Mean Square Error Combining (MMSEC)

If transmitting sequences had no correlation between users, it is possible to use mean square error between x_{k_0, k_1} and desired signals (d_{k_0} for $k_1=k_0$ and 0 for $k_1 \neq k_0$) for the cost function. The cost function J_{k_0} can be expressed by next formulas.

$$J_{k_0} = \sum_{k_1=1}^K E \left[\left| e_{k_0, k_1} \right|^2 \right] = E \left[\left| d_{k_0} \right|^2 \right] \left\{ 1 + W_{k_0}^H R_{AAk_0} W_{k_0} - W_{k_0}^H E \left[A_{k_0, k_0} \right] - W_{k_0}^T E \left[A_{k_0, k_0}^* \right] \right\} \quad (3)$$

$$R_{AAk_0} = \sum_{k_1=1}^K E \left[A_{k_0, k_1} A_{k_0, k_1}^H \right]$$

If $c_{k_0, n}^* c_{k_0, n}$ was assumed to 1, J_{k_0} can be simply expressed.

$$J_{k_0} = E \left[\left| d_{k_0} \right|^2 \right] \left(1 + W_{k_0}^H R_{AAk_0} W_{k_0} - W_{k_0}^H V_{k_0} - W_{k_0}^T V_{k_0}^* \right) \quad (4)$$

Optimum weight W_{k_0} that minimizes J_{k_0} should satisfy next equation.

$$\frac{\partial J_{k_0}}{\partial W_{k_0}} = E \left[\left| d_{k_0} \right|^2 \right] \left(2R_{AAk_0} W_{k_0} - 2V_{k_0} \right) = 0 \quad (5)$$

From (5), next optimum weight vector can be derived.

$$W_{k_0 \text{ MMSEC}} = R_{AAk_0}^{-1} V_{k_0} \quad (6)$$

2.3 Transmit Power Control (TPC)

SINR of k_1 mobile station is estimated by formula (7).

$$SINR_{k_1} = \frac{Q_{k_1} W_{k_1}^H E \left[A_{k_0, k_1} A_{k_0, k_1}^H \right] W_{k_1}}{\left(\sum_{k_0=1, k_0 \neq k_1}^K Q_{k_0} W_{k_0}^H E \left[A_{k_0, k_1} A_{k_0, k_1}^H \right] W_{k_0} \right) + \sigma^2} \quad (7)$$

Here, Q_{k_0} and σ^2 denote transmitting power for k_0 th mobile station and noise power of k_1 th mobile station. TPC operates to keep the estimated SINR a constant value.

3. Simulation

First, 1 path propagation model is evaluated in order to confirm a beam pattern. The parameters except for the path model are shown to Table 1. Fig. 3 shows beam

patterns based on MMSEC and MRC in case of Walsh-Hadamard sequence. Fig.4 shows the beam patterns in case of PN sequence. In these Figs, triangle denotes DOD (Direction of Departure) of the desired user, circles denote DOD of users which use the same sequence as the desired user, and dots denote DOD of users which use different sequence from the desired user. Using Walsh-Hadamard sequence and MMSEC, deep nulls direct to DODs of users which use the same sequence as the desired user. In the other cases, approximately the same patterns are formed. Since number of signals with high correlation becomes large and exceed freedom of the array in case of PN sequence, array antenna cannot direct nulls to all interference sources.

Next, user capacity of the proposed transmitter is evaluated. Path model shown to Fig. 2 has been assumed. Fig.5 shows relation between number of antenna elements and user capacity, which can achieve BER of 10^{-3} . When Walsh-Hadamard sequence and MMSEC are applied, user capacity increases about 3 times compared with the others. The efficiency of use of frequency is equivalent to 12bit/s/Hz in case of $M=8$ and $N=16$ with Walsh-Hadamard sequence and MMSEC.

4. Conclusion

A novel transmitter for MC-CDMA has been proposed and excellent increase of user capacity has been confirmed by the numerical simulation. It became clear that 8 elements array for space diversity and 16 subcarriers for frequency diversity provide efficiency of 12bit/s/Hz in case of Walsh-Hadamard sequence and MMSEC. We are to examine methods of estimating the response vector.

Reference

- [1] C.K.Kim, S.Choi and Y. S. Cho, "Performance Analysis of an MC-CDMA System with Antenna Array in a Fading Channel," IEICE Trans, Commun., Vol.E83-B, No.1, pp.84-92, 2000.
- [2] Y. Fujino and Y. Kuwahara, "MMSE Adaptive Antenna for OMC-CDMA Mobile Communication," Proc. of ISAPi-2002, pp.41-44, 2002.

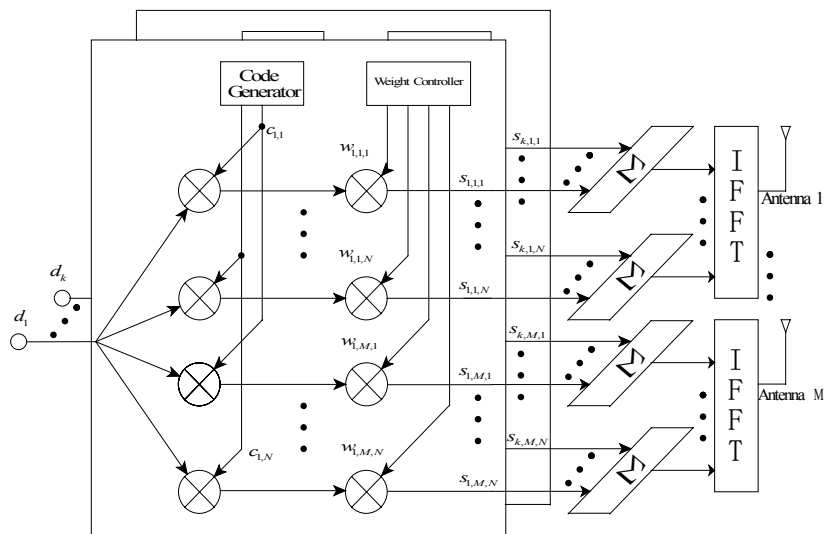

Fig. 1 Block diagram of transmitter with antenna array for MC-CDMA forward link

Table 1 Simulation parameters

| | |
|-------------------------------|--|
| Configuration of array | Uniformly spaced linear array |
| Element spacing | $\lambda/2$ |
| Number of subcarriers | 16 |
| Guard interval duration | 25% of the symbol duration |
| Path model | see fig. 2 |
| Direction of departure (deg.) | Uniformly distributed $[-60,60]$ |
| SNR | 20dB |
| Modulation | QPSK |
| Channel coding / decoding | convolutional coding(R=1/2, K=7) / 3bit soft-decision Viterbi decoding |

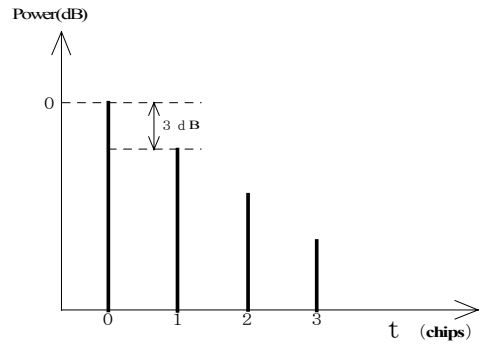

Fig. 2 Path Model

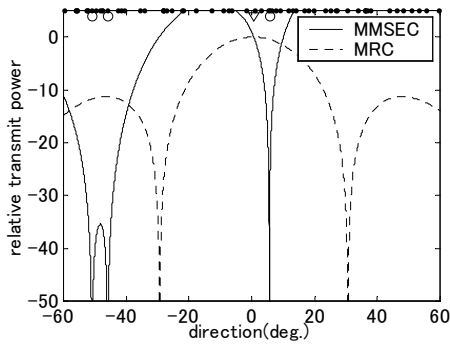

Fig. 3 Beam Pattern (Walsh-Hadamard Sequence)

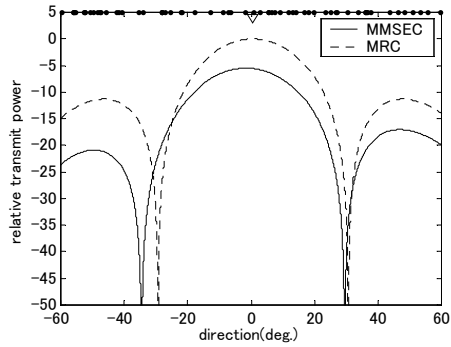

Fig. 4 Beam Ppattern (PN Sequence)

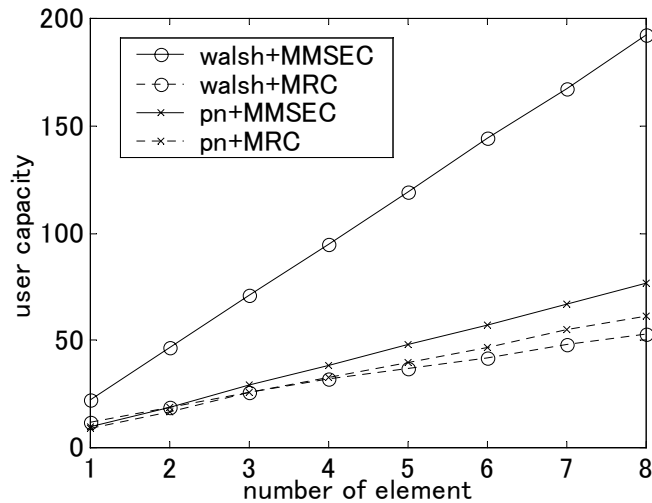

Fig. 5 User Ccapacity vs. Number of Elements