

FSS EQUIVALENT CIRCUIT EXTRACTION TECHNIQUES¹

J. H. Meloling*
Space and Naval Warfare Systems
Center San Diego
53560 Hull St.
San Diego, CA 92152

R. J. Marhefka
The Ohio State University
1320 Kinnear Rd.
Columbus, OH 43212

Introduction:

Equivalent circuit representations of frequency selective surfaces (FSS) are useful for quickly predicting the performance of FSS radomes. These equivalent circuit models also provide useful physical insight into the performance of the radome. Two different techniques for obtaining equivalent circuits for lossless FSS have been developed.

Technical Approach:

Equivalent circuit parameters have been determined for some very specific FSS geometries. These solutions tend to be restricted to square FSS geometries so that the solution can be derived from the impedance of periodic arrays of thin continuous conducting strips. These solutions result in approximate circuit parameters based on the physical geometry of the FSS [1-3].

The equivalent circuit extraction techniques developed in this paper are based on the performance of the FSS and not on the physical dimensions of the geometry. These arrays can be embedded in a general stratified medium since the solution is based on the admittance at the boundary where the FSS is located. These boundary admittances are computed using the Periodic Moment Method (PMM) code [4].

The equivalent circuit of an array of wire dipoles is a parallel combination of series RLC circuits as shown in Figure 1. All $R_i=0$ since the FSS layer is assumed to be lossless. This results in an admittance formula that is a summation of each of the resonant LC circuits. Each of the pole locations found by searching the computed boundary admittance data can be used to obtain a set of linear equations in terms of the unknown capacitances, C_i . Two procedures for solving this set of linear equations have been developed.

One method for computing the unknown capacitances is to use a linear least squares fit to the boundary admittance. This is accomplished using singular value decomposition since most least squares problems tend to be singular [5]. This method includes the ability to incorporate measurement uncertainty into the solution, σ_m . This is the procedure currently implemented in PMM when $\sigma_m=1$. It will be shown in the next section that the accuracy of the solution can be greatly increased by using σ_m as the known boundary admittance. This method works

¹ This work was sponsored by the Naval Sea Systems Command.

well if either computed or measured boundary admittance data is being used since all of the admittance data is used in the solution.

This system of equations can also be solved in closed-form if n -known admittance values are selected for the n -equations. The zero locations of the admittance data are used first. One additional data point must be selected since there are $n-1$ zeros. This selection is somewhat arbitrary. Empirically the admittance at a frequency of $\omega = 0.75\omega_{p1}$ works well (where ω_{p1} is the frequency corresponding to the first pole). These equations can now be solved explicitly or by solving the matrix equation. This method works well if computed boundary admittance data is being used. However, if measured data is used, it may be difficult to select the most accurate data for the solution.

Results:

The numerical calculation of equivalent circuits is presented for a simple FSS geometry. This geometry consists of a single layer of tripole elements embedded between two layers of dielectric material with a dielectric constant of 3.0 and a thickness of 20 mils each. This geometry is shown in Figure 2. The PMM code was used to compute the performance of the FSS geometry from 0.1-20 GHz. The boundary admittance data computed by PMM is used to determine equivalent circuit parameters.

Seven cases are presented to demonstrate the equivalent circuit extraction techniques. Case 1 consists of a linear least squares fit in which $\sigma_m=1$, the fit range is taken to be the entire 0.1-20 GHz and no extra shunt capacitance is included. Case 2 consists of a linear least squares fit in which σ_m is set to the boundary admittance, the fit range is taken to be the entire 0.1-20 GHz and no extra shunt capacitance is included. Case 3 consists of a linear least squares fit in which σ_m is set to the boundary admittance, the fit range is taken to be the entire 0.1-20 GHz, but an extra shunt capacitance is included. Case 4 consists of a linear least squares fit in which σ_m is set to the boundary admittance and an extra shunt capacitance, but the fit range is taken to be 0.1-18 GHz. Case 5 uses the closed-form technique over a fit range of 0.1-20 GHz and no extra shunt capacitance is included. Case 6 uses the closed-form technique over a fit range of 0.1-20 GHz but an extra shunt capacitance is now included. Case 7 uses the closed-form technique over a fit range of 0.1-18 GHz.

Equivalent circuits for these cases are computed and the results for parallel polarization are given in Table 1. The boundary reactance using these circuits is compared to the reactance computed using PMM. These results are shown in Figure 3. All cases show very good agreement with PMM except Case 1. This results from the fact that zero location information is not included in the solution when $\sigma_m=1$.

Table 1: Boundary admittance equivalent circuits.

	L_1 (pH)	C_1 (pF)	L_2 (pH)	C_2 (pF)	C_3 (pF)
Case 1	3321.5	0.08109	13102.0	0.00493	-
Case 2	3031.9	0.08884	3718.4	0.01739	-
Case 3	2879.0	0.09356	4682.9	0.01381	0.01330
Case 4	2865.1	0.09401	3569.3	0.01822	-
Case 5	2921.2	0.09221	3576.1	0.01808	-
Case 6	2935.3	0.09176	3723.3	0.01736	0.00183
Case 7	2918.5	0.09229	3634.2	0.01789	-

References:

- [1] R. Langley and E. Parker, "Equivalent circuit model for arrays of square loops," *Electron. Lett.*, vol. 18, pp. 294-296, Apr. 1982.
- [2] R. Langley and E. Parker, "Double-square frequency-selective surfaces and their equivalent circuit," *Electron. Lett.*, vol. 19, pp. 675-677, Aug. 1983.
- [3] C. Lee and R. Langley, "Equivalent-circuit models for frequency-selective surfaces at oblique angles of incidence," *Proc IEE, Part H*, vol. 132, pp.395-399, Oct. 1985.
- [4] L. Henderson, "Introduction to PMM, Version 4.0," Technical Report 725347-1, The Ohio State University, Department of Electrical Engineering, July 1993.
- [5] W. Press, B. Flannery, S. Teukolsky, and W. Vetterling, *Numerical Recipes: The Art of Scientific Computing*. Cambridge University Press, New York, 1986.

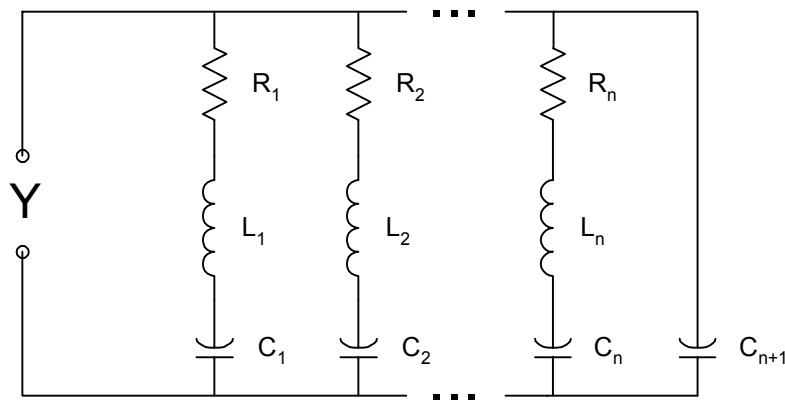

Figure 1: Equivalent circuit for a wire type FSS.

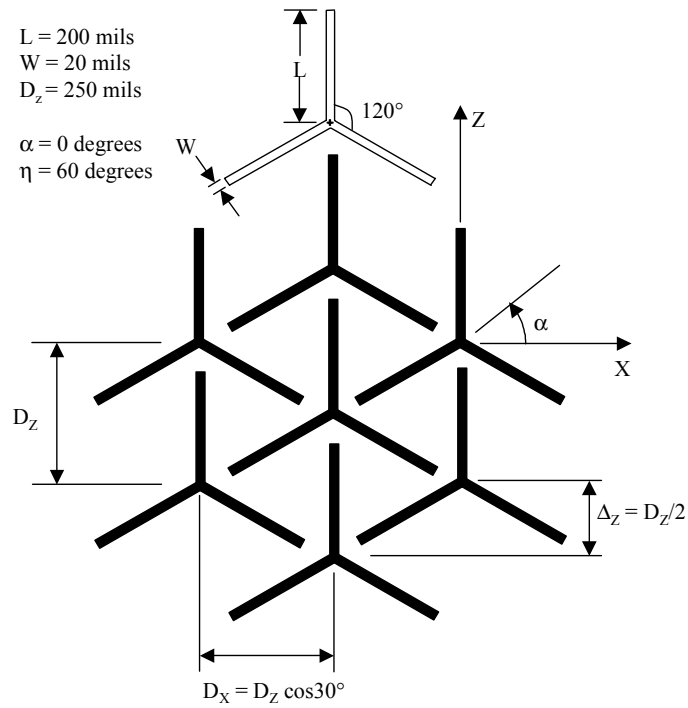

Figure 2: Tripole FSS array geometry.

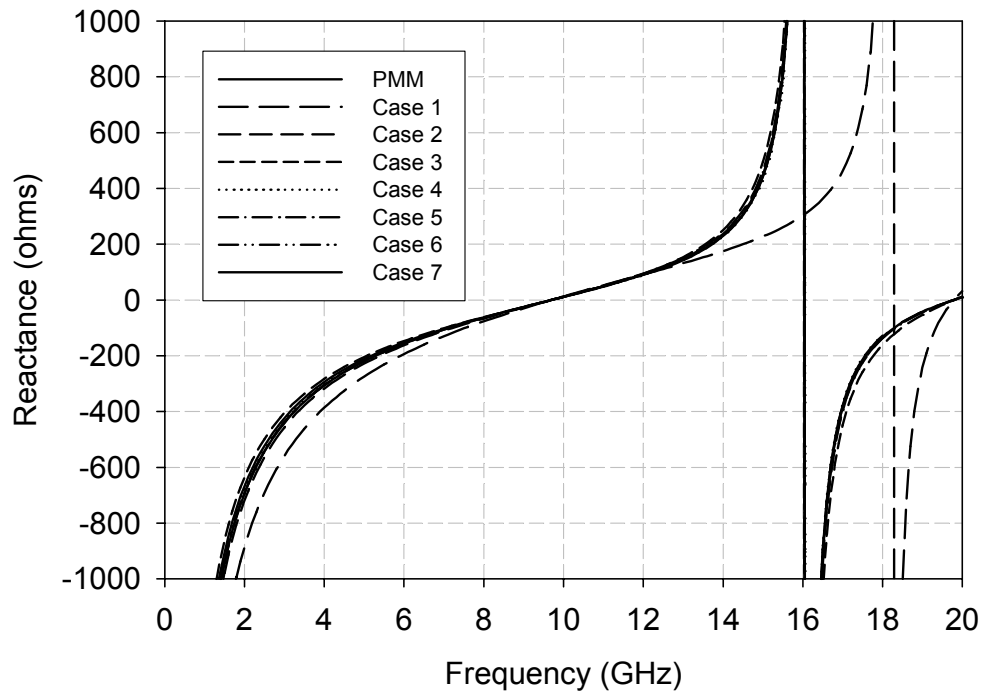

Figure 3: Boundary reactance comparison between PMM and equivalent circuits for parallel polarization.