

**National Academies of Science and Engineering
National Research Council
of the
United States of America**

**UNITED STATES NATIONAL COMMITTEE
International Union of Radio Science**



National Radio Science Meeting

June 25-29, 1984

**Sponsored by USNC/URSI
held jointly with
International Symposium of
Antennas and Propagation Society
Institute of Electrical and Electronics Engineers
Boston, Massachusetts
U.S.A.**

1984 IEEE/AP-S and URSI Technical Program

		MONDAY, JUNE 25	TUESDAY, JUNE 26	WEDNESDAY, JUNE 27	THURSDAY, JUNE 28	FRIDAY, JUNE 29
MORNING	ESSEX NORTH WEST	APS-1 TRANSIENTS Page 1	URSI/B-8 TRANSIENTS/NUMERICAL METHODS Page 75	PLENARY SESSION IN AMERICA SOUTH (AMNERICA BALLROOM LEVEL)	URSI/B-14 NUMERICAL METHODS II Page 169	
	ESSEX NORTH CENTER	URSI/B-1 RADIATORS NEAR MEDIA INTERFACES Page 1	APS-7 HIGH REQUENCY METHODS Page 213		APS-18 ELECTROMAGNETIC THEORY Page 691	
	ESSEX NORTH EAST	APS-2 SURFACE SCATTERING AND REMOTE SENSING Page 35	URSI/B-9 SCATTERING FROM OBJECTS NEAR MEDIA INTERFACES Page 87		URSI/B-15 INVERSE SCATTERING AND IMAGING Page 181	
	ESSEX SOUTH	URSI/B-2 ANTENNAS AND ARRAYS Page 11	APS-8 MICROSTRIP INTEGRATED CIRCUIT ANTENNAS I Page 249		APS-19 PRINTED ANTENNA ARRAY Page 727	AMTA NEAR FIELD MEASUREMENT TECHNIQUES WORKSHOP
	ESSEX CENTER	APS-3 ANTENNA ELEMENTS Page 53	APS-9 REFLECTOR ANTENNAS I REFLECTOR ANALYSIS & NUMERICAL INTEGRATION TECH Page 291		APS-20 REFLECTOR ANTENNAS III Page 757	
	ST. GEORGE "A", "B"		URSI/F-1 REMOTE SENSING OF EARTH ENVIRONMENTS Page 99		URSI/F-4 TROPOSPHERIC EFFECTS ON PROPAGATION Page 193	
	ST. GEORGE "C", "D"		APS-10 SOLAR POWERED SATELLITE CONCEPT REVISITED SPECIAL SESSION Page 335		APS-21 ADAPTIVE ANTENNAS Page 797	

Continued on Inside Back Cover

United States National Committee
INTERNATIONAL UNION OF RADIO SCIENCE

PROGRAM AND ABSTRACTS



1984 Spring Meeting
June 25-29

Held Jointly with
ANTENNAS AND PROPAGATION SOCIETY
INSTITUTE OF ELECTRICAL AND ELECTRONICS ENGINEERS

Boston, Massachusetts



TABLE OF CONTENTS

SESSION	PAGE NUMBER
B-1 Radiators Near Media Interfaces	1
B-2 Antennas and Arrays	11
B-3 Transients	23
B-4 Diffraction and Asymptotic Techniques	35
B-5 Random Media: Propagation and Scattering	47
B-6 Cad-Oriented Field and Network Analysis	59
B-7 Guided Waves	67
B-8 Transients/Numerical Methods	75
B-9 Scattering from Objects Near Media Interfaces	87
F-1 Remote Sensing of Earth Environments	99
B-10 Scattering	111
B-11 Microstrip and Stripline Antennas and Structures	123
F-2 Modelling and Measurement of Propagation Effects	135
B-12 Numerical Methods I	147
B-13 Electromagnetic Theory	157
B-14 Numerical Methods II	169
B-15 Inverse Scattering and Imaging	181
F-4 Tropospheric Effects on Propagation	193
B-16 Numerical Methods III	205
A-I Measurements for Antennas	215
B-17 Image Identification	227

STEERING COMMITTEE

Allan C. Schell, Chairman
Ronald Fante, URSI Vice Chairman
Robert J. Mailloux, AP-S Vice Chairman
Harold R. Raemer, Technical Program
Alan J. Simmons, Finance
David L. Fye, Local Arrangements
Richard J. Conti, Publications
Leonard M. Schwab, Advance Program
Steven R. Monaghan, Industry Participation
J. Claude Williamson, Publicity
B. Rama Rao, Banquet
Robert E. McIntosh, Centennial Program
Calvin T. Swift, Registration
Jerome D. Hanfling, Special Events
Marcia J. Hanfling, Guests Program
Philipp Blacksmith, Member at Large
Jeffrey S. Herd, Member at Large
Keith D. Huck, Member at Large
Daniel H. Schaubert, Member at Large

TECHNICAL PROGRAM COMMITTEE

Harold R. Raemer, Chairman
Edward Altshuler
C. Leonard Bennett
William C. Brown
Michael Burrows
Thomas S. Carberry
Jin Au Kong
Richard J. Conti
Clifford Krowne
S. J. Kubina
Jay Loomis
Robert McIntosh
Robert Mailloux
David Pozar
Sheila Prasad
Paul E. Rawlinson
Leon Ricardi
Ronald Row
Daniel Schaubert
John Schindler
Alan Simmons

URSI REPRESENTATIVES

Chalmers Butler
Robert Crane
Harry Cronson
Ronald Fante
Arthur Giordano

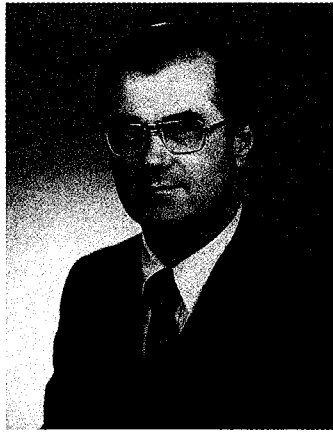

On behalf of the Steering Committee, I am pleased to welcome you to Boston for the 1984 IEEE International Symposium on Antennas and Propagation and National Radio Science Meeting. The Technical Program Committee has prepared an excellent series of sessions that span the spectrum of our interest. As part of the Centennial year of the Institute of Electrical and Electronic Engineers we have organized a special session at which five renowned speakers will look at the past, present, and future of antennas and propagation. There is a Centennial reception to which many contributors to our fields of endeavor have been invited.

This year the symposium is combined with a special workshop of the Antenna Measurement Techniques Association. Dr. Edward Joy of the Georgia Institute of Technology has organized a set of timely topics on near field techniques.

Boston is a city with many historical and cultural attractions, and the committee has chosen several feature events, including a clambake at the New England Aquarium, a performance of the Boston Pops Orchestra, and tours throughout the area. The Kennedy Presidential Library is the site for our Banquet, preceded by a tour of the exhibits.

I want to express my appreciation to all those who have given their time and energy for the success of this meeting. I hope your stay in Boston is a pleasant one, and that you find the conference both interesting and rewarding.

Sincerely

A handwritten signature in cursive script that reads "Allan C. Schell". The signature is written in dark ink on a white background.

ALLAN C. SCHELL
Chairman, Steering Committee

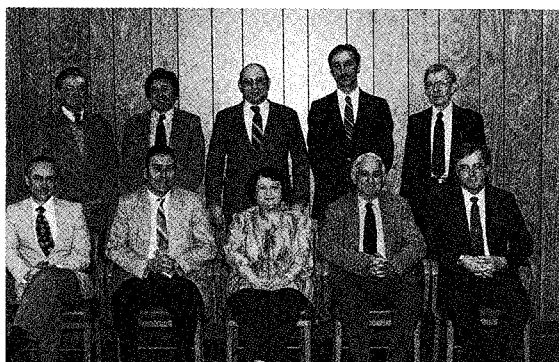

Members of the Steering Committee for the 1984 International IEEE/AP-S Symposium and National Radio Science Meeting. Standing (from left to right) Philipp Blacksmith, Richard J. Conti, Jerome D. Hanfling, Leonard M. Schwab, J. Claude Williamson; seated, Robert J. Mailloux, Ronald Fante, Marcia J. Hanfling, Harold R. Raemer, Allan C. Schell.



Other members of the Steering Committee are David L. Fye (left), Steven R. Monaghan, Alan J. Simmons, Robert E. McIntosh, Daniel H. Schaubert, and Calvin T. Swift.



Able assistance to the organization of the meeting was provided by B. Rama Rao (left), Keith D. Huck (center), and Jeffrey S. Herd.

A special acknowledgement is made for the assistance provided by Patricia A. Toomey, Michael Sarcione, Dianne Martin, Donna Percival, Nadine Dowling, Charlotte Sutherland and Linda Parsons.



URSI COMMISSION B



**SESSION B-1
RADIATORS NEAR MEDIA
INTERFACES**

Monday, June 25 8:30 AM - 12 NOON

Room: ESSEX NORTH CENTER

**Chairman: Jln Au Kong
Massachusetts Institute of
Technology, Cambridge, MA**

1. INPUT IMPEDANCE OF A SMALL VERTICAL MAGNETIC DIPOLE OVER A LOSSY HALF-SPACE, T. C. K. Rao, Electrical Engineering Department, University of Lowell, Lowell, MA.

2. THE CIRCULAR LOOP ANTENNA ABOVE A LOSSY DIELECTRIC SLAB, Robert D. Nevels and Michael M. Overly, Department of Electrical Engineering, Texas A&M University, College Station, Texas.

3. NUMERICAL INVESTIGATION OF INTERFACE EFFECTS ON HF-ANTENNA PROPERTIES, E. K. Miller, G. J. Burke, J. K. Breakall, J. K. King, R. J. Lytle, Lawrence Livermore National Laboratory, Livermore, CA.

4. DIAKOPTIC ANALYSIS OF AN OBLIQUE LINEAR ANTENNA ABOVE

HOMOGENEOUS EARTH, E. Niver, G. M. Whitman, Electrical Engineering Department, New Jersey Institute of Technology, Newark, NJ.

5. IMAGE OF A VERTICAL ELECTRIC DIPOLE ABOVE A METALLIC GRID, I. V. Lindell and E. Alanen, Helsinki University of Technology, Radio Laboratory, Espoo, Finland; V. P. Akimov, Leningrad Polytechnical Institute, Leningrad, USSR.

6. EXACT IMAGE SOURCES FOR THE SOMMERFELD PROBLEM, I. V. Lindell and E. Alanen, Helsinki University of Technology, Radio Laboratory, Espoo, Finland.

7. RESPONSE OF A SOURCE ON TOP OF A VERTICALLY STRATIFIED HALF-SPACE, W. C. Chew, Schlumberger-Doll Research, Ridgefield, CT.



Input Impedance of a Small Vertical Magnetic Dipole Over
a Lossy Half-Space

T.C.K. RAO

Electrical Engineering Department
University of Lowell, Lowell, MA

The input impedance of a small magnetic dipole over a finitely conducting half-space was obtained in a recent paper in the form of a rapidly converging Taylor series (Metwally and Mahmoud, Radio Sci, 16, 179-189, 1981). Their solution for the case of a magnetic dipole can be directly obtained by an extension of the image theory, where the image source is located in the lossy medium at a complex depth (Mohsen and Shafai, Can.J.Phys, 59, 117-121, 1981). The results obtained are shown to be consistent with earlier asymptotic solutions derived under the condition that the height of the antenna exceeds the skin depth in the lossy medium. Numerical results showing a comparison between the previous results and the present results will be presented, for the problem of a loop above a finitely conducting ground for different frequencies at different conditions ranging from a dry earth to wet earth.

URSI/B-1-2

THE CIRCULAR LOOP ANTENNA ABOVE A LOSSY DIELECTRIC SLAB

Robert D. Nevels and Michael M. Overly
Department of Electrical Engineering
Texas A&M University
College Station, Texas 77843

In this paper we analyze a circular loop antenna over a single layer lossy dielectric slab. The antenna lies in a plane parallel to the surface of the dielectric and the circumference of the loop is limited by the numerical procedure to less than approximately two wavelengths. Single and multiple delta gap feed cases are investigated. Input impedance is presented for the single feed case as a function of antenna height. Also power dissipation data is presented as a function of position in the lossy dielectric slab which represents a biological medium.

Electromagnetic heating of biological tissues has recently become an accepted method for treating tumorous cancers. Also it has been reported that bone fractures may in many cases be healed more rapidly by electromagnetically heating the region of the fracture. It has been shown that the most effective non invasive heating devices must produce an electric field with a small or non existant component tangential to the surface of the skin. This is because an electric field normal to the surface of the skin will deposit a significantly higher portion of the power in the surface fatty layer as apposed to the deeper muscle and bone layers. The circular loop which induces heating through the action of eddy currents is expected to be an important tool in thermal and hyperthermia biomedical work.

**NUMERICAL INVESTIGATION OF INTERFACE EFFECTS
ON HF-ANTENNA PROPERTIES***

E. K. Miller, G. J. Burke, J. K. Breakall,
J. K. King, R. J. Lytle

Lawrence Livermore National Laboratory
P.O. Box 5504, L-153, Livermore, CA 94550

Abstract

The most recent version of the Numerical Electromagnetic Code (NEC) has a capability for modeling wire objects located on either side of, or penetrating, a planar interface. As such, NEC represents a valuable tool for conducting numerical experiments designed to develop physical understanding of representative antenna types which are operated near the earth-air interface.

In this presentation we discuss a systematic parameter study of several antennas (e.g., monopole, beverage, slanted VEE) used for HF communications. We are motivated by the possibility of developing engineering design data from which practical rules-of-thumb may be derived for use in field applications. For example, it would be useful to know how long a ground stake is needed, or how many radials of what length, in what direction and over what angular sector are required, to achieve specified performance in given circumstances.

Our results are validated both by comparison with published experimental data and such consistency checks as varnishing of tangential electric field on the antenna wires and balance between input and radiated power (for lossless half spaces). By presenting summary design data in an easily implemented format, we hope to make it possible for the communications engineer to make useful tradeoffs among the various factors involved, particularly in field applications where quick design decisions are required. The ultimate goal of this work would be to provide a handbook that helps to achieve more effective utilization of the resources available in the field.

*Work performed under the auspices of the U. S. Department of Energy by the Lawrence Livermore National Laboratory under contract number W-7405-ENG-48.

URSI/B-1-4

DIAKOPTIC ANALYSIS OF AN OBLIQUE LINEAR ANTENNA ABOVE HOMOGENEOUS EARTH

E. NIVER, G.M. Whitman
Electrical Engineering Department
New Jersey Institute of Technology
Newark, NJ 07102

Diakoptic antenna theory (G. Goubau, et al, IEEE Trans Antennas Propagat., AP-30, 15-26, 1982) is extended to analyze an obliquely oriented linear antenna above homogeneous earth. This approach eliminates the need for an integral equation formulation to determine the current distribution, which is common to all other methods. A thin linear antenna is diakopted into electrically short segments. An impedance matrix is formed to model the coupling between these segments. A modified version of the diakoptic theory (F. Schwering, this meeting) is used which treats two adjacent segments as an individual element. This resulted in a simpler physical model and eliminates the interconnection matrices previously needed. Another advantage of this new approach is that it gives directly an equivalent circuit model for the antenna. Presence of the earth is taken into account through the reflection coefficient approach, which had been shown to be computationally effective and reasonably accurate for vertical and horizontal antennas (E.K. Miller, et al, Can. J. Phys., 30,879-888, 1972).

Oblique linear antennas of various lengths were considered above homogeneous earth. Results for current distributions and admittances are compared with that obtained by solving integral equations using the method of moments. This study also indicates that the diakoptic approach yields more stable numerical solutions compared to other methods.

IMAGE OF A VERTICAL ELECTRIC DIPOLE ABOVE A METALLIC GRID

I.V. Lindell and E. Alanen
Helsinki University of Technology, Radio Laboratory
Otakaari 5A, Espoo 15, 02150 Finland

V.P. Akimov
Leningrad Polytechnical Institute, Leningrad, USSR

The exact image principle, discussed for the Sommerfeld problem in a companion paper, is now applied to the problem of a vertical electric dipole above a plane metallic grid with square cells. The mesh size is assumed small compared to the wavelength and the wire diameter small compared to the mesh size, whence the Kontorovich averaged boundary condition is applicable. With this condition, the image current source is seen to be composed of two exponential line current waves located in complex space. The image source has the correct asymptotic behaviour in that it vanishes for the vanishing grid and approaches the image dipole of the perfect conductor plane for the extremely dense grid.

As examples of the usefulness of the image source we consider the TM surface wave excited by the vertical dipole and effect of the grid on the impedance of the dipole.

URSI/B-1-6

EXACT IMAGE SOURCES FOR THE SOMMERFELD PROBLEM

I.V. Lindell and E. Alanen
Helsinki University of Technology, Radio Laboratory
Otakaari 5A, Espoo 15, 02150 Finland

Exact image source theory is evaluated for the classical Sommerfeld problem of vertical magnetic dipole (VMD) or vertical electric dipole (VED) above the dissipative ground. Earlier theories have been approximate in one sense or another and the range of validity has not always been obvious. The present image sources are exact, which means that they are valid for any frequency, position of the dipole or the field point and parameters of the ground. In addition to this, the image source formulation offers a computational advantage when compared to the classical Sommerfeld integral computation. To obtain this, it is seen that the image line sources must be located in complex space, which does not make calculations more complex, but makes the sources converge in the best possible way.

The expression of the VMD image is obtained as a multiple of the function $J_2(x)/x$, whereas that of the VED has a more complicated appearance in terms of an integral expression. The latter is, however, not much more difficult to compute in practice than a Bessel function with a complex argument. The resulting field integral is nonsingular and due to the exponential decay of the Green function, it can be computed with a simple routine.

In our tests, 720 field integrals were computed for each of the dipole sources, applying a simple trapezoidal algorithm with 50 integration points. The field points were ranging over 6 decades both in horizontal and vertical direction and the ground parameters varied over 2.5 decades with 4 different phase angles. In typical results, the error observed was 1 % or below. For about 5 per cent of the integrals the error exceeded 5 %, for which the reasons could be explained. For example, for the VED, at the Brewster angle the relative error is large although the absolute error is not. Also, in some cases the surface wave may cause numerical trouble, which is removed when the integration points are either increased or unevenly distributed.

Response of a Source on Top of a Vertically Stratified Halfspace

W. C. Chew
Schlumberger-Doll Research
P.O. Box 307
Ridgefield, CT 06877

The solution of the response of a source on top of a horizontally stratified halfspace is well known, but when the halfspace is vertically stratified, it still remains an open problem. The first type of problem can be solved by Fourier integral technique which cannot be applied to the second type of problem. This is because the second type of problem is not easily separable by separation of variables even after Fourier transforms.

We present here two methods to solve this problem. One is a variational approach which simplifies in the low frequency regime giving rise to integrals which are numerically tractable on an ordinary computer. Another approach which is a semi-analytic method, is to reduce this multidimensional problem to a one dimensional numerical problem which is easily handled on a computer. In principle, this type of problem can be solved by the finite element method, but due to the infinite size of the halfspace, a straight forward use of the finite element method involves a multi-dimensional problem requiring a large amount of storage and computation time. However, an analytic transformation to reduce the dimension of the problem to one dimension greatly saves storage requirement and computation time, at the same time allowing a numerically accurate solution of the problem be obtained.

In the semi-analytic method, the problem is reduced to one dimension in each region, and the modal representation of the field in each region is obtained through a systematic and variational approach. The scattering of the halfspace is obtained through derivation of reflection and transmission operators through the matching of boundary conditions. A comparison of the two approaches to this problem will be made.

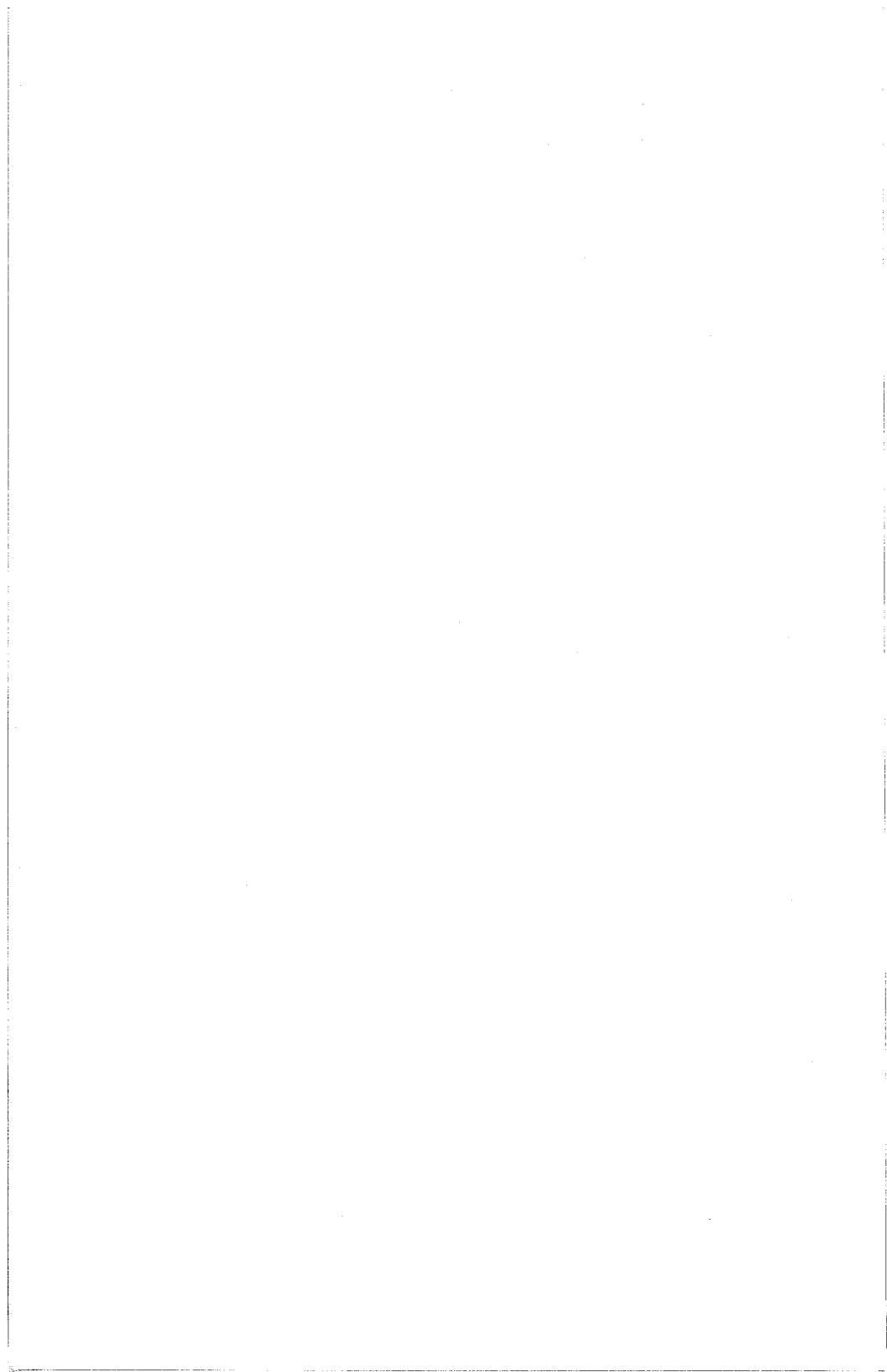



URSI COMMISSION B



SESSION B-2

ANTENNAS AND ARRAYS

Monday, June 25 8:30 AM - 12:00 NOON

Room: ESSEX SOUTH

Chairman: Y. T. Lo

University of Illinois, Urbana, IL

1. NUMERICAL TECHNIQUE FOR SHAPING OFFSET SUBREFLECTORS TO INCREASE MULTIBEAM ANTENNA COVERAGE,

C. J. Sletten, G. T. E. Communication Systems, Needham Heights, MA.

2. OPTIMUM DUAL-MODE CIRCULAR FEED FOR A SINGLE-OFFSET REFLECTOR,

V. Krichevsky, COMSAT Laboratories, Clarksburg, MD.

3. SIMPLE AND EFFICIENT COMPUTATION OF REFLECTOR ANTENNA APERTURE DISTRIBUTIONS AND FAR FIELD PATTERNS,

H. Steyskal, R. A. Shore, Electromagnetic Sciences Division, RADC, Hanscom Air Force Base, MA.

4. RADIATION FROM THICK PARABOLIC REFLECTORS,

R. Becker, W. M. Boerner, and P. L. E. Uslenghi, Department of Electrical Engineering and Computer Science, University of Illinois, Chicago, IL.

5. A NUMERICAL METHOD FOR NEAR-FIELD ARRAY SYNTHESIS,

David A. Hill,

Electromagnetic Fields Division, National Bureau of Standards, Boulder, CO.

6. ADMITTANCE OF AN INSULATED ANTENNA,

Eric M. Gurrola and Marvin E. Morris, Electromagnetic Analysis, Sandia National Laboratories, Albuquerque, NM.

7. ELF ANTENNA PATTERN DETERMINATION USING LIGHTNING,

Edwin A. Wolkoff and David H. S. Chang, Naval Underwater Systems Center, New London, CT.

8. SHORT BACKFIRE ANTENNA ARRAYS,

A. Kumar, Antenna Engineering, SPAR Aerospace Ltd, Quebec, Canada.

9. AN ARRAY ANTENNA ELEMENT PERMITTING ± 60 DEGREES ELECTRONIC SCANNING,

Erlend Cassel, Philips Electronikindustrier, Jarfalla, Sweden.

10. RADOME ANALYSIS FOR SPHERICAL DOME LENS PHASED ARRAY ANTENNAS,

Probir K. Bondyopadhyay, Department of Electrical Engineering and Computer Science, New York Institute of Technology, Old Westbury, New York.

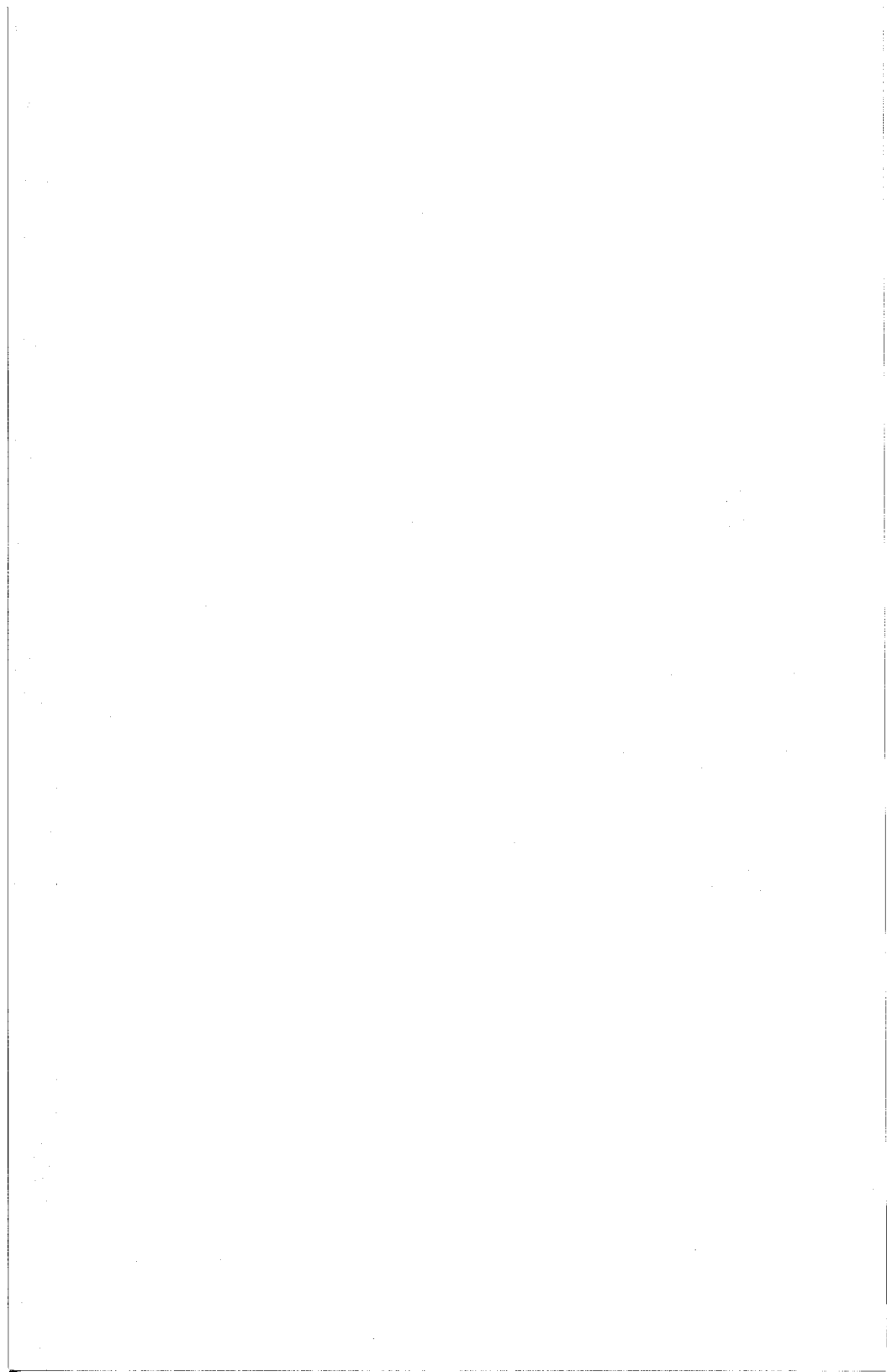

NUMERICAL TECHNIQUE FOR SHAPING OFFSET SUBREFLECTORS TO
INCREASE MULTIBEAM ANTENNA COVERAGE

C. J. Sletten, GTE Communication Systems,
Needham Heights, MA

Numerical computer techniques are described for shaping Cassegrain antennas to produce beamwidths in the range of 0.1° over angular sectors of 20° or more. The main antenna reflector is an offset paraboloidal section of circular edge contour with f/D and magnification configured to scan antenna patterns with -35 DB sidelobes. The method of shape synthesis first determines the hyperboloid's best focal surfaces and contours for best antenna patterns. Then using the phase information contained in the caustics of the paraboloid the Cassegrain surface is reshaped to focus sectors of the subreflector, corresponding to illuminated regions of the subreflector for selected scan angles, to the focal surfaces established for the unshaped subreflector. This refocussing technique is an extension of the "two point" correction technique used in wide angle optical lenses. The central portion of the subreflector is still the referenced hyperboloid and focusses the beams in a 4° cone with small gain losses. Because the tilt angles of the subreflector and feed are optimized antenna pattern quality is maintained with low cross polarization in the region around the paraboloid axis. The outer shaped portions of the subreflector extend the scanned beam angular region of good patterns out to about $\pm 12^\circ$.

The numerical surface shaping algorithms use 3 back-slopes and small projecting increments guided by discrete congruences of rays reflected from the paraboloid. The method is developed in both Basic and Fortran computer languages for rapid generation of the 3-dimensional surfaces and for fabrication. Programs are operational also for raytracing diagnostics to test performance over the extended scanning zones. Numerical methods for computing antenna patterns are described. Special analysis and software is presented to compute the skewed primary patterns needed for high gain and low cross polarization antenna performance over the wide multi-beam scanning sectors.

URSI/B-2-2

OPTIMUM DUAL-MODE CIRCULAR FEED FOR A SINGLE-OFFSET REFLECTOR*

V. Krichevsky
COMSAT Laboratories
Clarksburg, Maryland 20871

In this paper, we will consider the optimized dual-mode ($TE_{11} + TM_{11}$) circular waveguide as a feed for a single-offset reflector. A linear-polarized feed is located at the antenna focus. The principal polarization is in the antenna symmetry plane.

Two parameters, the ratio of the mode amplitudes (A) and the phase difference (ϕ) between the modes in the waveguide aperture, are used to minimize antenna cross-polarized radiation. Analytical expressions have been derived which express the parameters A and ϕ in terms of the antenna parameters. This solution reduces to a Potter horn for the case of the symmetrical reflector. Our approach to the problem consists of two steps. First, the reflector cross-polarized current is derived for arbitrarily assumed values of the A , ϕ -parameters. Second, using the min-max approach, both parameters are determined to minimize cross-polarized radiation. Several numerical results will be presented, and application of the results obtained will be discussed.

*This abstract is based upon work performed at COMSAT Laboratories under the sponsorship of the Communications Satellite Corporation.

SIMPLE AND EFFICIENT COMPUTATION OF REFLECTOR

ANTENNA APERTURE DISTRIBUTIONS AND FAR FIELD PATTERNS

H. Steyskal, R.A. Shore
Electromagnetic Sciences Division
RADC, Hanscom Air Force Base, MA 01731

Parabolic reflector antennas with small feed arrays are of interest because they feature the inexpensive high gain of a reflector and the flexibility of an array for beam shaping or scanning. The design process of such an antenna system requires a computer code for the radiation pattern of the various candidate configurations. Due to the large number of design parameters, this code will be run many times and must therefore be computationally efficient. This and the fact that the relative merits of a particular design can be judged from a limited pattern sector around the main beam, suggest an approach based on aperture field integration and the use of scalar field theory. In this paper we outline such a code and discuss some aspects of it.

First, we present the method to determine the aperture field. The essential features are the use of ray optics to map the off-axis feed onto the reflector aperture, the use of Fermat's principle to determine the ray path from the feed to a given aperture point, and the use of a rectangular grid of aperture sampling points.

Second, we compare the numerical efficiency of two aperture integration schemes, required for the pattern evaluation. One approximates the aperture distribution by rectangular subapertures with constant amplitude/linear phase excitation and sums their individual far field contributions, the other employs the Fast Fourier Transform and the Sampling Theorem [Bucci, Franceschetti, D'Elia, IEEE Trans. AP-28, 306-310, 1980].

Third, we examine the validity of using aperture field integration for some cases where patterns with relatively large off-axis angles and low sidelobe levels are involved. Patterns derived by reflector current integration and the geometrical theory of diffraction serve as a reference in these cases.

RADIATION FROM THICK PARABOLIC REFLECTORS

B. Beker, W.-M. Boerner and P.L.E. Uslenghi
Communications Laboratory

Department of Electrical Engineering and Computer Science
University of Illinois, Chicago, IL 60680

The two-dimensional problem of radiation from a parabolic cylindrical metal reflector fed by a parallel-plate waveguide located in the focal region of the reflector is considered. The finite thickness of the reflector is taken into account, and the two edges are modeled by a thick half-plane which is either abruptly truncated or rounded smoothly via a semicircular profile.

The integral equation for the surface current density on the reflector is solved numerically, and the far-field pattern is obtained. The results are compared with those available for a reflector of infinitesimal thickness. The effects of thickness and of edge termination on both the surface current distribution and the radiated field pattern are discussed.

In the far field, the numerical results are compared with the analytical predictions based on a combination of the geometrical theory of diffraction (including slope diffraction coefficients) and of Fock's theory. All results are given for both TE and TM polarizations. The extension to three dimensions (paraboloidal reflector) is also discussed.

A Numerical Method for Near-field Array Synthesis

David A. Hill
Electromagnetic Fields Division
National Bureau of Standards
Boulder, Colorado 80303

A numerical method for near-field array synthesis is developed for arbitrary antenna array elements and geometries. The intended application is for generating a plane wave field in a test volume for electromagnetic susceptibility testing of electronic equipment, but the method is valid for arbitrary field distributions. The numerical method chooses the element excitations to minimize the squared error in the tangential fields over the surface enclosing the test volume. In addition, a constraint is placed on the source norm (J.R. Mautz and R.F. Harrington, IEEE Trans., AP-23, 507-512, 1975) in order to control the level of the fields outside the test volume. Plane wave synthesis in the near field of a spherical array has been previously applied to antenna pattern measurements (J.C. Bennett and E.P. Schoessow, IEE Proc., 125, 179-184, 1978), but in that case the field error was minimized over a planar cut through the test volume. By minimizing the field errors over the closed surface, we find that the plane wave quality is good throughout the entire test volume.

The case of synthesizing a plane wave in the near field of a planar array of line sources has been studied numerically. The least squares synthesis without any constraint produces the smallest error, but in some cases the element excitations and the fields outside the test volume become unacceptably large. The constraint on the source norm is found to reduce the field level outside the test volume while causing only a small increase in the field error within the test volume. The synthesized results are compared with those of a uniform array, and the near field errors of a uniform array are much larger. The synthesis method is numerically efficient, and parameter studies are easily performed.

Suggested for URSI Commission B

URSI/B-2-6

ADMITTANCE OF AN INSULATED ANTENNA

Eric M. Gurrola and Marvin E. Morris

Electromagnetic Analysis
Division 7553
Sandia National Laboratories
Albuquerque, NM 87185

A theory is presented for the input admittance of an infinitely long, insulated, monopole antenna driven by a coaxial line. This admittance is derived in terms of the solution of a Fredholm integral equation of the first kind for the electric field in the gap at the drive to the antenna. This is intended as a realistic, canonical model from which to study junction effects as well as to compare simpler, approximate solutions. Wu (J. Math. Phys., Vol. 3, 1298-1301, 1962) initiated such a study for bare antennas and King et al. has pointed out the need for a similar study for insulated antennas (IEEE Trans. on Antennas and Propagation, 172-177, March 1975).

A numerical solution of the integral equation is obtained by a moments method using cubic spline basis functions. The edge singularity of the field is built into the solution explicitly. This solution is limited to frequencies low enough such that only the TEM mode propagates in the coaxial cable. The solution is compared with a solution for a delta function driven insulated antenna, a solution obtained by assuming only the TEM mode exists at the drive to the antenna, and with the transmission-line-like solution of King et al. Finally, a perturbation solution, which is useful in the case where the antenna radiates in a conducting media such as sea or lake water is obtained.

ELF ANTENNA PATTERN DETERMINATION USING LIGHTNING

Edwin A. Wolkoff and David H. S. Cheng
Naval Underwater Systems Center, New London, Ct. 06320

The US Navy is acquiring an ELF transmitter facility in Michigan. The new facility will be used in combination with an existing antenna array in Wisconsin to transmit messages in the 40 to 80 Hz. range to submarines.

Both arrays consist of several long horizontal conductors insulated from the earth on wooden poles for the most part or run through insulating material under roads and streams. The ends of the conductors are terminated by connection to copper electrodes in the earth. These grounds are several kilometers in extent. The antennas are energized at an intermediate point with modulated ELF currents.

In Michigan the array is made up of two east/west lines 22 kilometers long and a north/south line 45 kilometers long. The Wisconsin array is located 200 kilometers west south west and has two twenty-two kilometer long antennas, one running north/south and one east/west. The lines are only approximately orthogonal and follow irregular paths to ease construction and avoid populated areas.

In order to provide transmission coverage to areas of interest, it will be necessary to feed the antennas with a current of the appropriate phase. This will require that the pattern of the separate antennas be known. The patterns of the two antennas in Wisconsin were obtained previously by measurements of the magnitude of the radiated fields on arcs of 300 kilometer radius centered near the middle of the array.

This paper covers an attempt to determine an ELF antenna pattern by measuring the voltage induced in the antenna and the incident horizontal component of the magnetic field caused by distant lightning discharges.

Measurements required are similar to those made to obtain the tensor impedance of the earth by the magneto-telluric method. Differences are in the use of the ELF dipole antenna in place of the usual short electric dipole of magneto-tellurics, and in the interpretation of the measurements in terms of pattern rather than impedance. The ELF antennas are electrically short, but are five to ten skin depths long, while the usual MT dipoles are less than .01 skin depths long.

URSI/B-2-8

SHORT BACKFIRE ANTENNA ARRAYS

A. Kumar
Antenna Engineering
SPAR Aerospace Ltd
21025 Trans Canada Highway
Ste-Anne-de-Bellevue
Quebec
Canada

The paper describes the results of the development of a linear antenna array comprising short backfire elements, with a common large reflector. The antenna model was realised as a typical nonresonant broadside array, terminated in a matched load. The experimental measurements were performed in the frequency range 8.5 - 9.2 GHz and the main purpose was to optimize the antenna configuration with respect to the pattern quality.

The 3 dB beamwidth of the backfire array is 3.4° . The maximum sidelobes occur at about 40° and are -22 dB down with respect to the main lobe. For angle greater than $\pm 80^\circ$ the side lobes have levels less than -32 dB. The beamwidth of the main lobe at -22 dB is less than 12.5° . Vertical plane 3 dB beamwidth is less than 22° . The antenna array maintains its optimum pattern in the frequency range 8.6 to 8.9 GHz.

Comparisons with an array having a slotted waveguide in a flare show some advantages. The short backfire antenna array with comparable radiation characteristics has about half the number of elements and it is considerably shorter in depth leading to a significant reduction in weight. This backfire model is one example of many configurations possible with X-band backfire elements. Using a printed circuit feed system instead of metal waveguide an additional decrease in the backfire dimensions is possible.

AN ARRAY ANTENNA ELEMENT PERMITTING ± 60 DEGREES
ELECTRONIC SCANNING

Erland Cassel

PHILIPS ELECTRONIKINDUSTRIER AB
S-175 88 Järfälla Sweden

This paper presents an array antenna element with an aperture of about half a wavelength square. The element design is such that the mutual coupling to adjacent elements is low.

The antenna element, the ordinary array phase shifter and the array antenna scanning processor are made to cooperate in such a way that the boresights of all the antenna elements always are pointing in about the same direction as the boresight of the entire array.

This means that the element beam factor is close to maximum for all array scan angles, for example when you are scanning within ± 60 degrees.

The ordinary problem of pattern nulls in certain beam directions is thus eliminated. It also means a reduction of the sidelobe level.

Measured data will be given.

URSI/B-2-10

RADOME ANALYSIS FOR SPHERICAL DOME LENS PHASED ARRAY ANTENNAS

by

Probir.K.Bondyopadhyay
Department of Electrical Engineering
and Computer Science
New York Institute of Technology
Old Westbury, New York 11568

Spherical Dome Lens phased array antenna is a novel concept in conformal phased arrays whereby a planar phased array antenna radiating through the lens is capable of electronically scanning the entire hemisphere or more.

Numerical analysis for the radiating arrays of waveguide fed circular apertures on conducting spherical surfaces have been done by Hessel, Shmoys and Liu (Y-L Liu Ph.D. dissertation, Polytech. Inst. of N.Y., 1976) for the element by element case and by Hessel and Bondyopadhyay (P.K. Bondyopadhyay, Ph.D. dissertation, Polytech. Inst. of N.Y., 1982) for arrays with rotational symmetries.

These two works have been extended to include upto two layers of dielectrics on top of the spherical array. Spherical transmission line impedance relations are used to transform the spherical mode impedances from one radial interface to another. Principal plane radiation patterns have been computed for various dielectric cover parameters (thickness and dielectric constants). The results are compared with those without any dielectric cover and the work that has been done on similar arrays on cylindrical structures.

This work was supported by a research grant from the New York Institute of Technology.



**URSI COMMISSION B
SESSION B-3
TRANSIENTS**



**Monday, June 25 1:30 - 5:00 P.M.
Room: ESSEX NORTH WEST
Chairman: L. Wilson Pearson
University of Mississippi, University, MS**

1. TRANSIENT RESPONSE TO A LINE SOURCE EXCITATION IN CYLINDRICAL GEOMETRY, A. Sezginer and J. A. Kong, Department of Electrical Engineering and Computer Science and Research Laboratory of Electronics, Massachusetts Institute of Technology, Cambridge, MA.

2. TRANSIENTS IN A RESISTIVELY LOADED LOOP ANTENNA, Motohisa Kanda, National Bureau of Standards, Electromagnetic Fields Division, Boulder, CO.

3. ON THE TRANSIENT OF THE MULTI-CONDUCTOR OVERHEAD TRANSMISSION LINE, O. Oboul-Atta and G. Bridges, Department of Electrical Engineering, University of Manitoba, Winnipeg, Manitoba, Canada.

4. THEORETICAL IMPULSE RESPONSE ESTIMATION FOR ELECTROMAGNETIC SCATTERERS, G. D. Poe, Lawrence Livermore National Laboratory, Livermore, CA.

5. LOCAL INFLUENCE TECHNIQUE TO COMPUTE RESPONSE OF SCATTERING CENTER, Harry Mieras, Raytheon Company, Missile Systems Division, Bedford, MA.

6. MULTI-PORT NETWORK REPRESENTATION FOR TRANSIENT SCATTERING, Michael A. Morgan, Department of

Electrical Engineering, Naval Postgraduate School, Monterey, CA.

7. EXPERIMENTAL DETERMINATION OF OPTIMUM SENSOR LOCATION ON AIRCRAFT FOR TRANSIENT ELECTROMAGNETIC MEASUREMENTS, V. V. Liepa and S. Pennock, Department of Electrical and Computer Engineering, The University of Michigan, Ann Arbor, MI.

8. A NOVEL ANALYSIS OF MULTI-PORT NONLINEARLY LOADED ANTENNAS, A. R. Djordjevic and Tapan K. Sarkar, Department of Electrical Engineering, Rochester Institute of Technology, Rochester, N.Y.

9. COMPLEX RAY INTERPRETATION OF TRANSIENT SCATTERING FROM TARGETS WITH INFLECTION POINTS, H. Ikuno and L. B. Felsen, Department of Electrical Engineering and Computer Science/Microwave Research Institute Polytechnic Institute of New York, Farmingdale, N.Y.

10. WAVEFRONTS AND RESONANCES IN TRANSIENT SCATTERING BY A FLAT STRIP, H. Shirai and L. B. Felsen, Department of Electrical Engineering and Computer Science/Microwave Research Institute Polytechnic Institute of New York, Farmingdale, N.Y.; E. Heyman, Department of Electrical Engineering, Tel Aviv University, Israel.

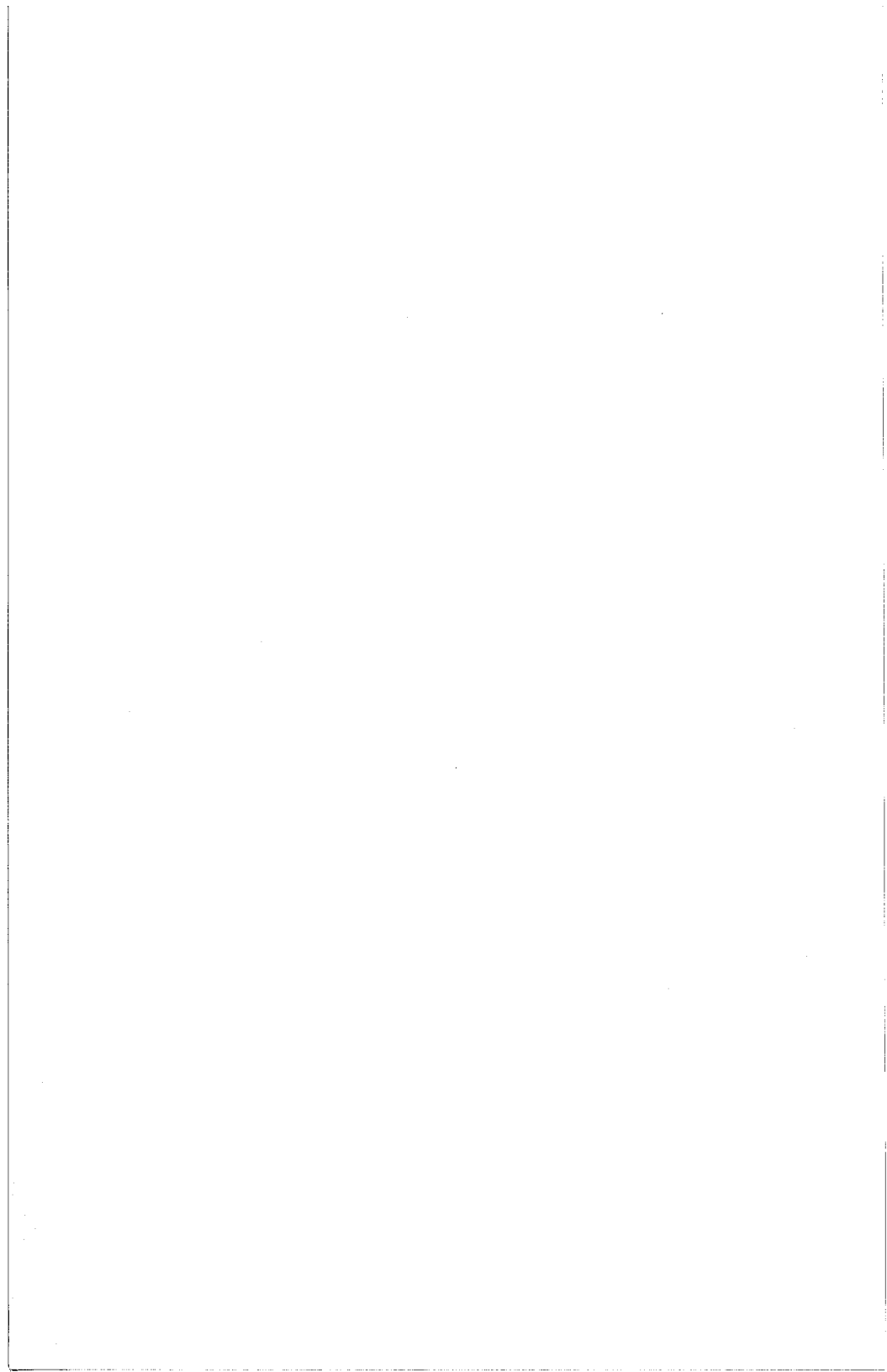

TRANSIENT RESPONSE TO A LINE SOURCE
EXCITATION IN CYLINDRICAL GEOMETRY

A. Sezginer and J.A. Kong

Department of Electrical Engineering and Computer Science
and Research Laboratory of Electronics
Massachusetts Institute of Technology
Massachusetts, Cambridge 02139

The transient electric field due to a line source, located at the axis of a lossless dielectric cylinder, which is buried in another dielectric medium, is evaluated. Two complementary approaches are used. Singularity expansion method (SEM) is efficient to compute the slowly varying parts of the response. An approximate explicit inversion approach is used to compute the rapidly changing parts of the response. Results obtained by both techniques agree very well, when sufficiently large number of poles are taken in the SEM calculation.

In the SEM, the response is expressed as a summation of a branch cut contribution, and pole contributions due to the TM_{0n} cavity modes. The branch cut contribution is a smooth function of time, after the first arrival. The sum of pole contributions represent the multiple reflections from the cylindrical boundary. An approximate analytical expression is given for the pole contributions.

In the explicit inversion technique, the response is expressed as an infinite sum, whose index of summation is the number of reflections experienced by the wave front. Approximate, analytical expressions are given for all terms. The reflections that cross the cylinder axis odd number of times, before reaching the observation point, are expressed as the finite Hilbert transforms of the terms that cross the axis even number of times. The finite Hilbert transform is introduced to make high frequency approximations without destroying the causality of the response.

URSI/B-3-2

TRANSIENTS IN A RESISTIVELY LOADED LOOP ANTENNA

Motohisa Kanda
National Bureau of Standards
Electromagnetic Fields Division
Boulder, CO 80303

This paper analyzes the transient characteristics of a loop antenna loaded uniformly with a resistive material. Such loaded antennas are useful in reducing the effects of loop resonances and in shaping the transient electromagnetic waveform. Previously the singularity expansion method (SEM) representation for a resistively loaded loop was derived and has been used in time- and frequency-domain analysis. In this paper the loop current distribution is obtained by the use of a Fourier series expansion. The resistive loading is then treated as a series of lumped resistive loads.

Consider a small loop with lumped resistive loads at ϕ_m in an incident plane wave field. The total current is the sum of the currents maintained by electromagnetic forces at ϕ_m and the incident field E_0^i . That is,

$$I(\phi) = 2\pi E_0^i u(\phi) - \sum_{j=0} I(\phi_j) Z_j v(\phi_j, \phi),$$

where

$$u(\phi) = -\frac{1}{\pi \zeta} \left(\frac{f_0}{a_0} + \frac{2f_1 \cos \phi}{a_1} \right)$$

and

$$v(\phi, \phi') = -\frac{j}{\pi \zeta} \left(\frac{1}{a_0} + \frac{2 \cos \phi \cos \phi'}{a_1} \right).$$

Here f and a are, respectively, the Fourier expansion coefficients for the incident electric field and the two dimensional free space kernel of the scalar wave equation. By setting $\phi_m = 2\pi m/M$ ($m = 0, 1, \dots, M-1$), the currents $I(\phi_m)$ at ϕ_m can be determined by solving the $M \times M$ matrix of simultaneous equations.

It is possible to achieve broadband response of a loop antenna by resistive loading. However, the resistive loading drastically reduces the sensitivity of the magnetic response of the antenna, whereas the electric response is not changed significantly. This paper discusses the theoretical and experimental results for the time- and frequency-domain representation of the receiving transfer function of a resistively loaded loop antenna.

ON THE TRANSIENT OF THE MULTI-CONDUCTOR
OVERHEAD TRANSMISSION LINE

O. Aboul-Atta and G. Bridges
Department of Electrical Engineering
University of Manitoba, Winnipeg, Manitoba, Canada R3T 2N2

Much attention has recently been paid to the understanding and calculation of the electromagnetic transient in overhead transmission lines with sufficient accuracy for time domain diagnostics and applications. This presentation discusses our development in that area and its impact on the solution of the exact formulation of the impulse response [Wait, Radio Science, 7, 675-679, 1972]. Since the improvement due to Perel'man in 1963 [E.E. Sci. Rep. No. 27, Univ. of Colorado, 1977] over Carson's evaluation of the Sommerfeld integral ($F=K+R+G$), through the use of Bessel and Struve functions to gain accuracy, the literature documents other approaches of assessing the modal propagation constant and modal surge impedance. Two of the well known approaches are the electromagnetic transient program EMTP, used by power utilities, and the fast mode degeneracy introduced by Olsen et al. [Electronics Letters, 10, 92-94, 1974]. Our analytical development stays consistent with that of Perel'man, where an exact solution of the (K+R) function is available with no restriction and an extended asymptotic expression of the G function for small arguments is incorporated. A comparison of the calculated modal propagation constant with previously published results is shown (see figure) to indicate the inaccuracy encountered by using the different approaches [accepted for publication, Electronics Letters].

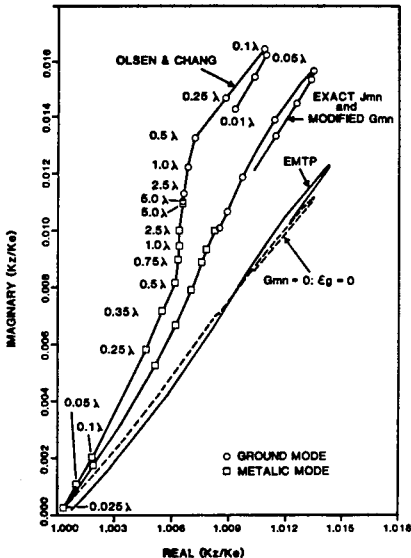

The method employed in extracting the propagating modes and surge impedances of the eigenmodes of an arbitrary multi-conductor system will be presented. The transformation matrix of the eigenvectors (current, voltage) is shown to be frequency dependent and is incorporated when obtaining the time domain solution under the Fourier transform and its inverse. Some theoretical test cases will be shown in order to emphasize the various conclusions we have reached on the time domain simulation of transients in overhead transmission lines.

URSI/B-3-4

THEORETICAL IMPULSE RESPONSE ESTIMATION FOR ELECTROMAGNETIC SCATTERERS*

G. D. Poe

Lawrence Livermore National Laboratory
P.O. Box 5504, Livermore, CA 94550

Abstract

An algorithm for estimating the plane-wave impulse response of a smooth perfectly conducting scatterer is presented. The algorithm operates on uniformly spaced frequency-response samples on the closed interval $[0, (ka)_{\max}]$, where k is the wave number and a is a major dimension of the scatterer. For those scatterers that have been treated, the highest frequency used as data, $(ka)_{\max}$, must be greater than eight for highly accurate extrapolation. The extrapolation yields an estimate of the frequency response for frequencies beyond $(ka)_{\max}$ and an estimate of the impulse response, which is the Fourier transform of the frequency-response estimate. The frequency-response samples on $[0, (ka)_{\max}]$ may be obtained with any method of solving the electromagnetic wave equation, e.g. separation of variables for simple shapes. Example impulse-response and frequency-response estimates are presented as examples.

*Work performed under the auspices of the U. S. Department of Energy by the Lawrence Livermore National Laboratory under contract number W-7405-ENG-48.

LOCAL INFLUENCE TECHNIQUE TO COMPUTE
RESPONSE OF SCATTERING CENTER

Harry Mieras
Raytheon Company, Missile Systems Division
Bedford, Massachusetts 01730

The Space Time Integral Equation (STIE) is adapted to the problem of obtaining the localized response of a scattering center. Called the Local Influence Technique (LIT), the method can be applied to arbitrary targets with arbitrarily shaped scattering centers, when the separation between scattering centers is at least several pulse lengths. It is useful for target/scattering center sizes too small for adequate treatment by asymptotic methods, but too large for complete integral equation solution.

The STIE is particularly well suited to a local technique, since its time-stepping solution traces the surface current as it evolves in space and time away from the scattering center. The response of leading scattering centers (speculars, leading edges, or protrusions) is found readily by direct application of the STIE; but the computation of the response of trailing scattering centers requires a special method.

The H-Field STIE is used:

$$\vec{J}(\vec{r}, t) = 2\hat{A} \times \vec{H}^i(\vec{r}, t) + \frac{\hat{A}}{2\pi} \times \int_S \left(\frac{1}{R} + \frac{\partial}{\partial t} \right) \vec{J}(\vec{r}', t-R/c) \times \hat{R} \, dS'$$

$R = |\vec{r} - \vec{r}'|$

The LIT approach is to write the total surface current as the sum:

$$\vec{J}(\vec{r}, t) = \vec{J}_E(\vec{r}, t) + \vec{J}_C(\vec{r}, t).$$

Here \vec{J}_E is the surface current on an "extended" body with simplified geometry which is locally smooth. $\vec{J}_E(\vec{r}, t)$ is obtained by a simplified efficient, application of the STIE or by other methods. The correction current, \vec{J}_C , is the perturbation on \vec{J}_E due to the scattering center. $\vec{J}_C(\vec{r}, t)$ evolves in time away from the scattering center and can be computed by a localized solution of the STIE. This approach can be used for any incidence angle.

Results are given for smooth speculars and curved edges (which can be compared with simple PO and GTD results) and also for the ends of a long cylinder (for which the complete effect of the end currents is included).

URSI/B-3-6

MULTIPOINT NETWORK REPRESENTATION FOR TRANSIENT SCATTERING

Michael A. Morgan
Department of Electrical Engineering
Naval Postgraduate School
Monterey, CA 93943

An equivalent multipoint network representation for the transient scattering process is developed by way of appropriate integral equations. This model is shown to provide a heuristic description of both the early-time driven response and the late-time natural resonance response. The equivalent network is used as the basis for the construction of optimum scattered signal processing filters for detection and target identification. Test results are presented for validation of the theory.

EXPERIMENTAL DETERMINATION OF OPTIMUM SENSOR LOCATION ON AIRCRAFT FOR TRANSIENT ELECTROMAGNETIC MEASUREMENTS

V. V. Liepa and S. Pennock
Radiation Laboratory
Department of Electrical and Computer Engineering
The University of Michigan
Ann Arbor, MI 48109

To study the characteristics of lightning, aircraft have been instrumented (Baum et al., IEEE Trans. EM Compat., 24, 123-137, 1984) and flown through thunderstorms to measure currents and charges on the aircraft when it is struck by lightning. The NASA F-106 is such an aircraft and has been used for direct strike measurements since 1980. Likewise, the surface currents and charges induced on the aircraft from nearby lightning strikes can also be measured and from these the properties of the lightning strikes are deduced.

One of the main problems when the sensors are mounted on an aircraft is that the sensors respond not only to the incident (i.e., lightning) excitations but to the aircraft responses as well. To obtain a meaningful measurement it is important that a sensor be placed on or near the aircraft so that the field scattered by the aircraft is not received by the sensor.

In this paper the experimental study and some of the results are presented in which the optimum location of a B-dot sensor on a F-106 aircraft to measure the incident magnetic field in the direction of the aircraft fuselage were determined. In the study magnetic field measurements were performed in an anechoic chamber using a 1:72 scale F-106 model illuminated by a plane electromagnetic wave using a small current loop.

Amplitude and phase data were recorded for various locations near the aircraft over 118-4400 MHz (1.6 - 61 MHz full scale). The measurements were made with and without the model and hence a comparison of the two measurements provides a degree of field distortion or error for each location and direction of excitation tested.

URSI/B-3-8

A NOVEL ANALYSIS OF MULTIPOINT NONLINEARLY LOADED ANTENNAS

A. R. Djordjevic and Tapan K. Sarkar
Department of Electrical Engineering
Rochester Institute of Technology
Rochester, New York 14623

Abstract: Time Domain analysis of loaded antennas have been described by Miller et.al, Landt and Bennett. Tesche and Liu has extended this approach to treat nonlinearly loaded antennas. In this paper we present an approach which extends the work of previous researchers to treat nonlinearly loaded antennas with arbitrary excitations. This work differs from the previous works in the following ways: (1) We develop a time domain green's function for the linear antennas by terminating them suitably. This ensures a time limited Green's function. Thus you need less frequency domain information. (2) Therefore the application of this technique to arbitrary excitation is just a straight forward convolution. (3) We can easily handle the analysis of multipoint nonlinear loads without much problem as we have solved the linear problem and obtained a Thevenin's equivalent. Examples will be presented to illustrate the application of this technique to multipoint nonlinearly loaded antennas.

COMPLEX RAY INTERPRETATION OF TRANSIENT SCATTERING FROM TARGETS
WITH INFLECTION POINTS

H. Ikuno* and L.B. Felsen
Department of Electrical Engineering and Computer Science/
Microwave Research Institute
Polytechnic Institute of New York
Farmingdale, NY 11735

*Visiting Professor from Department of Information Engineering,
Kumamoto University, Japan

In a previous investigation, the high-frequency spectral contributions in numerical results for transient backscattering from a perfectly conducting object with convex-concave boundary shape were interpreted by the physical optics method [H. Ikuno, Int. URSI Symp., Compostela, Spain, 1983]. In addition to the real stationary points at the conventional specular reflection points on the illuminated part of the surface, the physical optics integral was found to contain complex stationary points with real parts located near the (non-specular) concave-to-convex inflection points. The numerical diffraction pattern also contains dips that seemed to be interpretable as reflections of creeping waves from concave-to-convex transitions on the shadowed part. The problem is now being re-examined by regarding the complex stationary point contributions as reflections of complex incident rays from the analytic extension of the boundary into a complex coordinate space. It has been verified that complex incident rays obtained by analytic extension of the real incident ray field are reflected from concave-to-convex inflection points on the illuminated part of the extended surface according to the laws of complex geometrical optics to yield a real contribution in the backscatter direction. The corresponding complex ray treatment of reflected creeping waves is presently being studied. Conclusions reached so far suggest that a systematic analysis of scattering by convex-concave targets can be carried out by incorporating complex rays into the spectrum of reflected and reflected-diffracted (creeping) rays. Examples will be shown to support this contention.

URSI/B-3-10

WAVEFRONTS AND RESONANCES IN TRANSIENT SCATTERING BY A FLAT STRIP

H. Shirai*, E. Heyman** and L.B. Felsen*

*Department of Electrical Engineering and Computer Science/
Microwave Research Institute
Polytechnic Institute of New York
Farmingdale, NY 11735

**Department of Electrical Engineering, Tel Aviv University, Israel

Transient scattering by an obstacle can be analyzed either in terms of successive wavefront arrivals or in terms of complex resonance (SEM) contributions. The resonance expansion can be generated by collective summation of the multiple wavefronts which, for a strip, arise from successive diffractions between the edges. However, it has been found that certain early wavefront arrivals cannot be incorporated into the collective treatment [E. Heyman and L.B. Felsen, Proceedings of the NATO Workshop on Hybrid Formulation of Wave Propagation and Scattering, Nijhoff Pub. Co., 1984]. Such arrivals correspond to specular reflection and to single diffraction at either edge. They do not depend on the finite size of the object, which is essential for the resonance formulation. Thus, these "non-summable" contributions play the role of the entire function which must augment the resonance expansion. It is possible, by retaining some of the early "summable" wavefronts in addition to the non-summable ones, to construct a hybrid formulation containing wavefronts and resonances (plus a remainder term) in uniquely defined proportion. The summable wavefronts replace a group of high-frequency resonances, and all of the retained wavefronts play the role of an alternative entire function. These ideas, which are related to SEM turn-on and switch-on times, are demonstrated by numerical results for the plane wave impulse response based on GTD treatment of edge diffraction. Although the GTD approximation introduces errors at low frequencies, the alternative formulations listed above are found to be consistent within this approximation.



**URSI COMMISSION B
SESSION B-4**



**DIFFRACTION AND ASYMPTOTIC
TECHNIQUES**

Monday, June 25 1:30 - 5:00 P.M.

Room: ESSEX NORTH CENTER

Chairman: David C. Chang

University of Colorado, Boulder, CO

1. SYSTEMS OF INTEGRAL EQUATIONS OF THE WIENER-HOPF TYPE IN DIFFRACTION THEORY, Albert E. Heins, Department of Mathematics, The University of Michigan, Ann Arbor, MI.

2. SCATTERING BY A LINEARLY TAPERED RESISTIVE HALF PLANE, Thomas B. A. Senior and Seung-In Yang, Radiation Laboratory, University of Michigan, Ann Arbor, MI.

3. AN EXTENSION OF THE UTD FOR ANALYZING THE RADIATION WITHIN PARAXIAL REGIONS BY SOURCES ON CONVEX SURFACES, P. H. Pathak and A. Altintas, The Ohio State University ElectroScience Laboratory, Columbus, Ohio.

4. SURFACE RAY SOLUTION FOR THE SURFACE FIELDS ON A CURVED REACTIVE SURFACE, J.R.J. Paknys and N. Wang, The Ohio State University ElectroScience Laboratory, Columbus, Ohio.

5. GEOMETRIC OPTICS FROM A NUMERICALLY DEFINED SURFACE-2-D CASE, Mark Tew and Srdan Filipovich, Department of Electrical Engineering, University of Mississippi, University, MS.

6. CALCULATION OF NEAR-FIELD OF

A REFLECTOR BY GTD, P. T. Lam and S. W. Lee, University of Illinois, Urbana, IL; R. Acosta, NASA-Lewis Research Center, Cleveland, OH.

7. SECOND-ORDER EDGE DIFFRACTION EFFECTS ON FINITE ELLIPTIC CONES AND DISKS, D. S. Y. Wang and L. N. Medgyesi-Mitschang, McDonnell Douglas Research Laboratories, St. Louis, MO.

8. ASYMPTOTIC DIFFRACTION BY A DOUBLE WEDGE, A. Elsherbeni and M. Hamid, Antenna Lab., Electrical Engineering Department, University of Manitoba, Winnipeg, Manitoba, Canada.

9. A UNIFORM ASYMPTOTIC APPROACH TO HIGH FREQUENCY RADAR CROSS SECTION PREDICTION, Earl C. Burt, Syracuse Research Corporation, Syracuse, New York.

10. A UNIFORM CLOSED FORM SOLUTION FOR THE HIGH FREQUENCY DIFFRACTION BY A PAIR OF PARALLEL WEDGES, A. Michaeli, Electromagnetic Research Department, Armanent Development Authority, Haifa, Israel.

SYSTEMS OF INTEGRAL EQUATIONS OF THE WIENER-HOPF
TYPE IN DIFFRACTION THEORY

Albert E. Heins
Department of Mathematics
The University of Michigan
Ann Arbor, MI 48109

This paper will discuss the progress which has been made in the study of integral equations of the Wiener-Hopf type which arise in diffraction theory since the August 1981 meeting of the U.R.S.I. [A. E. Heins, "The Status of Systems of Wiener-Hopf Integral Equations"]. A number of examples have been recently produced by A. E. Heins ["The Sommerfeld Half-Plane Problem Revisited," I,I,III: Mathematical Methods in the Applied Sciences 4(1982) 74-90; 5(1983) 14-21; and 5(1983) 257-275; and R. A. Hurd and E Lüneburg ["Scattering of Hard and Soft Parallel Half Planes" Canadian Journal of Physics 59(1981) 1879-1885; "Diffraction by an Infinite Set of Hard and Soft Parallel Half-Planes" Canadian Journal of Physics 60(1982) 1-9 and "Diffraction by an Infinite Set of Soft/Hard Parallel Half-Planes" Radio science (1982) 453-462.] All of this work is based on an idea suggested by Heins in 1948 ["Systems of Wiener-Hopf Integral Equations and Their Application to some Boundary Value Problems in Electromagnetic Theory"; Proceedings of the Symposia in Applied Mathematics, Vol. II (1950) 76-81]. Though V. G. Danielle [On the Factorization of Wiener-Hopf Matrices in Problems Solvable with Hurd's Method" I.E.E.E. Transactions on Antennas and Propagation AP-26 (1978) 614-616] has suggested that there is a class of problems based upon this idea which is always tractable, it turns out that there are some questions in complex analysis which have to be examined before some of the problems, which have recently been encountered, can be treated. This report will be devoted to a discussion of some of these problems.

URSI/B-4-2

SCATTERING BY A LINEARLY TAPERED RESISTIVE HALF PLANE

Thomas B.A. Senior and Seung-In Yang
Radiation Laboratory
University of Michigan
Ann Arbor, MI 48109

When using resistive sheet materials for cross section reduction purposes, it may be effective to allow the resistivity to vary over the surface. In the case of strips, for example, it has been shown numerically (T.B.A. Senior and V. V. Liepa, Backscattering from tapered resistive strips, unpublished) that a smooth variation of the resistivity from one edge of the strip to the other can reduce the near edge-on backscattering below that of a uniform strip, but to develop asymptotic formulas for the scattering it is necessary to have available the solution of the corresponding canonical problem, i.e. a half plane with tapered resistivity.

If the electric vector is parallel to the edge, a case for which the exact solution can be obtained is a half plane whose resistivity increases linearly with distance from the edge (see, for example, L. B. Felsen and N. Marcuvitz, Radiation and Scattering of Waves; Prentice-Hall, 1973, pp. 674 et seq.). Using the Kontorovich-Lebedev integral transform, the scattered field can be expressed as an integral in the complex plane and then evaluated in terms of residues. The edge diffraction coefficient is computed as a function of the angles of incidence and scattering and the (constant) rate of change of the resistivity. Not surprisingly, the effective phase center is no longer located at the edge. The reflection coefficient and the total induced current are also determined and compared with the corresponding results for uniform resistive half planes.

AN EXTENSION OF THE UTD FOR ANALYZING THE RADIATION
WITHIN PARAXIAL REGIONS BY SOURCES ON CONVEX SURFACES

P.H. Pathak and A. Altintas

The Ohio State University ElectroScience Laboratory
1320 Kinnear Road
Columbus, Ohio 43212

A recently developed uniform geometrical theory of diffraction (UTD) solution for the problem of the radiation by sources on smooth perfectly-conducting convex surfaces [Pathak et al., IEEE Trans. AP-29, No. 4, pp. 609-622, July 1981] continues to be used, very successfully, for analyzing the radiation in all directions except within the paraxial zones of quasi-cylindrical surfaces where it is not valid. That UTD solution is generalized in this paper to make it valid within the paraxial regions of elongated convex bodies. A conventional asymptotic analysis of the related canonical problem of the radiation by a source on a circular cylinder fails within the paraxial region because the asymptotic large parameter no longer remains large in the paraxial limit. Thus, in this work, an accurate asymptotic solution for the surface fields due to a source on a convex surface has first been obtained; this surface field remains valid in the paraxial zones. Next, that surface field is incorporated into the radiation integral which is evaluated asymptotically to find the radiated field. Some recent attempts by others to asymptotically evaluate the fields radiated by currents on a convex surface gave inaccurate results. A more correct asymptotic procedure is therefore employed here, and its accuracy is established by noting that it properly recovers all the leading terms of the previously obtained UTD solution; such a test is not satisfied by the other procedures. The generalization of the previous UTD solution to include paraxial zones is possible via higher order terms obtained in this work; several important applications of this result will be discussed.

URSI/B-4-6

CALCULATION OF NEAR-FIELD OF A REFLECTOR BY GTD

P. T. Lam and S. W. Lee
University of Illinois
Urbana, Illinois

R. Acosta
NASA-Lewis Res. Center
Cleveland, Ohio

The use of GTD (including uniform theories) to calculate the pattern of an arbitrary subreflector was reported by S. W. Lee, et al. (IEEE Trans. AP-27, 305-316, 1979). In this paper GTD is used to calculate the near-field of a main reflector. Our calculation accomplishes the following: (i) The pattern measurement of a large reflector antenna is usually done in a near-field range. Our calculation provides a theoretical check of such a measurement. (ii) The extrapolation of a far-field pattern from the near-field data can be carried out by well-known techniques (FFT for example). Thus our calculation of the near-field may be considered as an alternative way for obtaining the secondary pattern of a main reflector. (A similar work was reported by Y. Hwang, C. H. Tsao and C. C. Han, AP Digest, p. 88, May 1983, Houston, TX.)

Several features of our GTD calculations are worth mentioning. (i) Both UAT and UTD are included in our computer program. A user may choose either one to calculate the field in the transition region near a shadow boundary. (ii) Both the shape of the main reflector and its boundary are arbitrary. (iii) Our near field includes both GO and edge diffracted fields. Hence, the secondary pattern calculated from them is asymptotically correct to the order of $O(k^{-1/2})$ relative to the incident field. Note that the popular physical optics method for secondary pattern calculation cannot claim such an accuracy, because its surface current is assumed to be $\hat{2}n \times \vec{H}^i$ and does not include the fringe current.

SECOND-ORDER EDGE DIFFRACTION EFFECTS
ON FINITE ELLIPTIC CONES AND DISKS

D.-S. Y. Wang and L. N. Medgyesi-Mitschang
McDonnell Douglas Research Laboratories
St. Louis, MO 63166

A physical theory of diffraction (PTD) based formulation is presented to study the scattering from finite elliptic cones and disks. The present analysis incorporates the second-order edge diffraction utilizing an equivalent current representation similar to the one by Knott and Senior (Proc. IEEE, 62, No. 11, 1468, 1974). The present formulation differs from the cited work in that the diffraction coefficients used are valid when the field and source points are in close proximity. The tip-rim interaction on cones is investigated as a function of the tip-rim distance and cone angle for circular cones. Its implication for elliptic cones is discussed. A hybrid formulation using MM with a Fock Ansatz (IEEE Trans. Antennas Propagat., AP-31, No. 4, 570, 1983) is used for comparison. For cones, the total scattered field is computed using the contributions from the first- and second-order edge diffraction and also secondary surface-wave effects, such as creeping waves from a Fock theory-based Ansatz. For disks, the scattered field is due to the first- and second-order edge diffraction, as well as the physical optics (PO) contribution.

Results of the present formulation are compared with published data for circular cones and disks, and with new experimental results for elliptic cones and disks for various ellipticity and angles of illumination.

URSI/B-4-8

ASYMPTOTIC DIFFRACTION BY A DOUBLE WEDGE

A. Elsherbeni and M. Hamid
Antenna Lab., Elec. Eng. Dept.,
University of Manitoba,
Winnipeg, Canada, R3T 2N2

Following an approximate technique by Karp and Russek for the diffraction by a wide slit, an asymptotic expression for the far diffracted field due to a plane wave incident on two semi-infinite wedges is derived in terms of the unperturbed field due to the two wedges in isolation plus an interaction term due to an equivalent inhomogeneous line source at each edge. Numerical results for the diffraction pattern, transmission coefficient, equivalent line source intensity and interaction term are presented for wide as well as narrow double wedges and are in good agreement with previous results by Teague and Zitron as well as Keller and Mohsen for the special case of diffraction by a slit.

A UNIFORM ASYMPTOTIC APPROACH TO HIGH FREQUENCY
RADAR CROSS SECTION PREDICTION

Earl C. Burt
Syracuse Research Corporation
Syracuse, NY 13210

High frequency scattering from perfectly conducting polygonal plates and generalized spheroidal frusta has been analyzed for the prediction of the bistatic RCS of complex targets. The approach has been to combine physical optics with an equivalent current formulation of the physical theory of diffraction which accounts for the first-order diffraction from sharp edges and discontinuities in the surface normal. Uniform closed-form approximations to the radiation integrals have been obtained, allowing the location and the magnitude of the return of each scattering center to be determined. The approach is unique in that, while the concepts of surface and edge currents are used to eliminate many of the problems that a strictly ray-tracing technique has in RCS applications, closed-form expressions rather than numerical methods are used to evaluate the resultant integrals, providing the same simplicity and efficiency one enjoys in a ray-tracing procedure.

A set of computer programs has been developed to implement this analysis, and to aid in the creation and display of target model data files. After designating a target geometry, the user selects the radar parameters, the relative radar-target locations, and the range of angles and sampling rate for the predictions. Mutual- and self-shadowing effects are automatically accounted for by using efficient algorithms based on the scattering center concept.

Examples of comparisons between predictions and measured data will be presented, together with a brief description of the asymptotic method used in the scattering analysis.

URSI/B-4-10

A UNIFORM CLOSED FORM SOLUTION FOR THE HIGH FREQUENCY DIFFRACTION BY A PAIR OF PARALLEL WEDGES

A. Michaeli

Electromagnetic Research Department,
Armament Development Authority,
P.O. Box 2250, 31021 Haifa, ISRAEL

A new asymptotic analysis of the high-frequency scattering by a pair of parallel wedges is presented resulting in a uniform, closed form approximation to the doubly diffracted field. The main advantage of this approximation over the recent result (Tiberio and Kouyoumjian, Radio Sci., 17, 323-336, 1982) is that it is not restricted to the second edge lying strictly on the shadow or reflectron boundary of the first wedge, or the observation point lying on the shadow or reflection boundary of the second wedge. Instead, it applies uniformly throughout the transition regions surrounding the above boundaries. Another advantage of this solution is its closed form; although subject to the limitation that the incident wave between the edges be representable as plane and the observation point be in the far scattered field, this form provides greater practical usefulness.

The analysis presented is based on a generalization of the physical theory of diffraction (PTD) in which the radiation integral over the actual induced currents is replaced by a Chu-Stratton integral over a surface enclosing the wedges. A term-by-term relationship is established between the GTD ray decomposition of the scattered field and the asymptotic decomposition of the radiation integral into endpoint contributions. The closed form expressions obtained for the various endpoint contributions to the singly-diffracted field are used in a generalized STD (spectral theory of diffraction) analysis of the doubly-diffracted field to cast the latter in an integral form satisfying the principle of reciprocity. The integral is over a steepest descent path and its integrand has two simple poles near the saddle point. An asymptotic evaluation of this integral yields a non-uniform closed-form approximation to the doubly diffracted field. An Ansatz based on the uniform theory of diffraction (UTD) in combination with a singularity matching procedure is proposed to transform this approximation into a uniform one. The latter includes terms to order k^{-1} .



URSI COMMISSION B



SESSION B-5

**RANDOM MEDIA: PROPAGATION AND
SCATTERING**

Monday, June 25 1:30 - 5:00 P.M.

Room: ESSEX NORTH EAST

Chairman: Akira Ishimaru

University of Washington, Seattle, WA

1. SCATTERING OF ELECTROMAGNETIC WAVES BY A RANDOMLY PERTURBED QUASI-PERIODIC SURFACE, R. T. Shin and J. A. Kong, Department of Electrical Engineering and Computer Science and Research Laboratory of Electronics, Massachusetts Institute of Technology, Cambridge, MA.

2. ON THE APPLICATION OF THE GENERALIZED METHOD OF SMOOTHING TO ROUGH SURFACE SCATTERING, Gary S. Brown, Applied Science Associates, Inc., Apex, N.C.

3. POLARIMETRIC RADIATIVE TRANSPORT DESCRIPTION OF PROPAGATION THROUGH ENSEMBLES OF DISCRETE HOMOGENEOUS SCATTERERS IN AN INHOMOGENEOUS MEDIUM, Ali M. Khounsary and Wolfgang-M. Boerner, Electromagnetic Imaging Division, Department of Electrical Engineering and Computer Science, University of Illinois at Chicago, Chicago, IL.

4. MODIFIED RADIATIVE TRANSFER EQUATION IN STRONG FLUCTUATION APPROACH, Y. Q. Jin and J. A. Kong, Department of Electrical Engineering and Computer Science and Research Laboratory of Electronics, Massachusetts Institute of Technology, Cambridge, MA.

5. FURTHER DEVELOPMENTS IN THE SINGULARITY EXPANSION METHOD-MULTIPLE SCATTERING THEORY,

Douglas J. Riley, Sandia National Laboratories, Albuquerque, NM; William A. Davis, Electrical Engineering, VPI&SU, Blacksburg, VA.

6. GREEN FUNCTION AND RADIATION OVER RANDOM ROUGH SURFACE, Hisanao Ogura and Nobuyuki Takahashi, Department of Electronics, Kyoto Institute of Technology, Kyoto, Japan.

7. ON THE SECOND ORDER DOPPLER RETURN FROM AN OCEAN SURFACE, J. Walsh and S. K. Srivastava, Faculty of Engineering and Applied Science, Memorial University of Newfoundland, St. John, Newfoundland, Canada.

8. A COMPARISON OF A DIFFRACTION MODEL WITH A DIFFUSE SURFACE SCATTERING MODEL IN A BISTATIC GEOMETRY, Robert J. Papa, John F. Lennon, Richard Taylor, Electromagnetic Sciences Division, Rome Air Development Center, Hanscom AFB, MA.

9. THE RENORMALIZED WAVE-INTEGRAL EQUATION AND APPLICATIONS, David A. de Wolf, Department of Electrical Engineering, VPI & SU, Blacksburg, VA.

10. A STUDY OF BACKSCATTERING AND EMISSION FROM CLOSELY PACKED INHOMOGENEOUS MEDIA, A. K. Fung and H. J. Eom, Remote Sensing Laboratory, University of Kansas, Lawrence, Kansas.

SCATTERING OF ELECTROMAGNETIC WAVES
BY A RANDOMLY PERTURBED QUASI-PERIODIC SURFACE

R. T. Shin and J. A. Kong

Department of Electrical Engineering and Computer Science
and Research Laboratory of Electronics
Massachusetts Institute of Technology
Cambridge, Massachusetts 02139

In the active remote sensing of plowed fields, it is well known that the radar backscattering coefficients change as a function of the observation angle relative to the row directions. We use the Kirchhoff approximation to study the scattering of electromagnetic waves from a randomly perturbed quasi-periodic surface. Since plowed fields possess random variations on the period and amplitude of the sinusoidal variation as we move from one row to the next, we model this variation by introducing a narrow-band Gaussian random process on top of the basic sinusoidal variations, which causes the surface to be quasi-periodic. The physical optics integral is evaluated to obtain closed form solutions for both the coherent and incoherent bistatic scattering coefficients. In the geometrical optics limit, it is shown that the bistatic scattering coefficients are proportional to the probability of the occurrence of the slopes which specularly reflect the incident wave to the observation direction.

The theoretical results are illustrated for the various cases by plotting the backscattering cross sections as a function of the angle of observation. It is shown that there is a large difference between the cases where the incident wave vector is parallel or perpendicular to the row direction. When the incident wave vector is perpendicular to the row direction, the maximum value of the backscattering cross section does not necessarily occur at normal incidence. The scattering coefficients can be interpreted as a convolution of the scattering patterns for the sinusoidal and the random rough surfaces. The locations and magnitudes of the peaks occurred in the backscattering coefficients are explained in terms of the scattering patterns for the sinusoidal rough surface.

URSI/B-5-2

ON THE APPLICATION OF THE GENERALIZED METHOD OF SMOOTHING TO ROUGH SURFACE SCATTERING

Gary S. Brown, Applied Science Associates, Inc.,
105 East Chatham Street, Apex, N.C. 27502

The method of smoothing is a technique which has become very popular in the applied mathematics community for determining the average (coherent) field in continuous random media. One particular subset of this technique is a perturbation expansion [J. B. Keller, Proc. Symp. in Appl. Math., 13, 227-246, 1962] which has recently been applied to rough surface scattering [J. G. Watson & J. B. Keller, Submitted to JASA, 1983]. There is, however, a more generalized method of smoothing [U. Frisch, Probabilistic Methods in Applied Mathematics, A. T. Bharucha-Reid (Ed), 1961] which does not explicitly use perturbation. In this method, the field is decomposed into the sum of an average value and a fluctuating part and the fluctuating part is formally solved via iteration to yield, in the propagation problem, an integral equation for the average field. The kernel of the resulting integral equation comprises an infinite number of terms and when one considers only the lowest order term the result is equivalent to the perturbation-based solution. With all terms present in the kernel, the generalized method of smoothing appears to be more powerful than perturbation; however, it must be remembered that there is no guarantee (or proof) that the series comprising the kernel converges.

In this paper the generalized method of smoothing is applied to a slightly modified form of the Magnetic Field Integral Equation (MFIE). The modification entails multiplying the equation by the factor $\exp(jk\zeta)$ where k is an arbitrary wavenumber and ζ is the stochastic surface roughness; the average of the product of the current and this exponential factor yields a quantity whose two-dimensional coordinate space Fourier transform is proportional to the average scattered field. Using the fact the average scattered field is specular [G. S. Brown, IEEE Trans., AP-30, 1135-1144, 1982], it is shown that the generalized method of smoothing yields a matrix equation for the average scattered field complex amplitude rather than a matrix integral equation. The sizes of the matrices are related to the number of terms retained in the (formal) iterative solution for the fluctuating field. The lowest order term, in a specific limit, reduces to the physical optics approximation but, in general, appears to represent a definite and rather straightforward improvement to physical optics.

POLARIMETRIC RADIATIVE TRANSPORT DESCRIPTION OF PROPAGATION THROUGH
ENSEMBLES OF DISCRETE HOMOGENEOUS SCATTERERS IN AN INHOMOGENEOUS MEDIUM

Ali M. Khounsary and Wolfgang-M. Boerner
Electromagnetic Imaging Division
Communications Laboratory/SEL 4210
Department of Electrical Engineering &
Computer Science/SEO 1141
University of Illinois at Chicago
851 S. Morgan St.
P.O. Box 4348
Chicago, IL 60608

The study of electromagnetic propagation in random media has, in recent years, attracted increasing attention, particularly in response to the advent of terrestrial and earth-space communication systems, and also a result of its applications in the areas of detection and remote sensing.

An important feature of wave propagation in random media which has, until recently been largely ignored, is multiple scattering effects and the resulting incoherent field. For example, in the areas of (satellite) communication, saturation of low and moderate frequency channels has resulted in utilization of higher operating frequencies at which multiple scattering due to the presence of hydrometeors along the propagation path gives rise to incoherent fields, depolarization and cross-polarization.

One approach to the problem of multiple scattering is provided by the radiative transport theory. This theory which is valid for media with low particle density and is considered to be the closest to a general formulation of particulate scattering.

The radiative transfer equation which governs the variation of intensity in participating media, has not yet been solved in its general three dimensional form. However, in many practical situations, a plane parallel geometry can reasonably be assumed and for this case several solution procedures are available. The adding-doubling method which is used in this study is one such procedure. It begins with a layer of differential optical depth $\Delta\tau$ of the medium for which a single scattering approximation is valid. By adding this layer to itself, whereby doubling the optical depth, and repeating the procedure, the solution for finite plane parallel media is obtained. For inhomogeneous plane parallel media, finite homogeneous layers are constructed and then added.

The adding-doubling method has been extended through the introduction of the Stokes' parameters in vectorial radiative transfer equation for homogeneous plane parallel media, to include polarization.

In the present study (A.M. Khounsary, Ph.D. Thesis), we consider the case of inhomogeneous plane parallel media (which can include reflecting boundaries) and develop an efficient computer code for the solution of the vector radiative field. The accuracy of the solution is assessed and the possibility of extending the method to denser media of various scatterers and to two and three dimensions is discussed.

URSI - F: Millimeter Wave Propagation

URSI/B-5-4

MODIFIED RADIATIVE TRANSFER EQUATION IN STRONG FLUCTUATION APPROACH

Y. Q. Jin and J. A. Kong

Department of Electrical Engineering and Computer Science
and Research Laboratory of Electronics
Massachusetts Institute of Technology
Cambridge, Massachusetts 02139

Stokes form

The strong fluctuation theory has been applied in the study of wave scattering and propagation through a bounded layer of densely distributed random discrete scatterers. By properly taking into account the singularity in the dyadic Green's functions, we obtain the Dyson equation under the non-linear approximation and the Bethe-Salpeter equation under the ladder approximation. With the introduction of the spectral density of the scattered fields, the modified radiative transfer (MRT) equation is derived from the covariance equation.

From the MRT equation, we obtain the backscattering cross sections and the forward scattering coefficients which are shown to be consistent with those derived from a rigorous wave approach. The interference due to coherent interactions between the two boundary surfaces are studied in relation to the layer thickness, wavelength, polarization, and background medium properties. The scattering phase matrices in the MRT equation are compared with that in the radiative transfer (RT) equation for spherical Rayleigh scatterers. It is shown that as the fractional volume of scatterers is very small, the phase matrix of the RT equation is in good agreement with that of the MRT equation. However, when the fractional volume increases, the agreement becomes poor owing to the independent scattering assumption inherent in the RT approach. When the background medium permittivity is chosen as the effective permittivity, this discrepancy will be smaller until the fractional volume reaches approximately 40 per cent. Further increase in the fractional volume will eventually lead to the breakdown of the independent scattering assumption, and the RT approach must be replaced by the MRT approach.

FURTHER DEVELOPMENTS IN THE SINGULARITY EXPANSION
METHOD-MULTIPLE SCATTERING THEORY

Douglas J. Riley
Sandia National Laboratories
Albuquerque, NM 87185

William A. Davis
Electrical Engineering
VPI&SU
Blacksburg, VA 24061

Recently, a new application which merged the classical theory of multiple scattering and the singularity expansion method was presented by these authors (Proceedings of the International Symposium on Electromagnetic Theory, August, 1983). This paper introduced the concept of a pole distribution to characterize wide stopbands for propagation through the atmosphere. The solution form which was developed was clearly suggestive of the attenuation versus frequency curves typical of microwave through optical propagation.

The original paper limited the discussion to only perfect electric conducting (PEC) objects, and therefore, the practical application of the equations developed was clearly limited. This paper extends the original contribution by presenting the following: (1) specific results for the previously presented PEC equations for the case of a slab containing a random collection of PEC spheres, and (2) a development for dielectric objects analogous to the PEC development previously presented. The extension to dielectric objects then lends the method, in principle, to applications of practical interest.

GREEN FUNCTION AND RADIATION OVER RANDOM ROUGH SURFACE

Hisanao OGURA and Nobuyuki TAKAHASHI

Department of Electronics, Kyoto Institute of Technology
Matsugasaki, Kyoyo, 606, Japan

In previous papers (Nakayama et. al., Radio Sci, 15, 1049, 1980; 16, 381, 1981), the authors have developed a new probabilistic method to deal with the scattering of plane wave by a random surface and clarified various scattering characteristics. In this paper the radiation field by a point source located above the random surface, namely the Green function, is obtained as a stochastic functional of the homogeneous random surface by integrating the stochastic wave solutions for incident plane wave with arbitrary incident angle. The random surface is assumed to be a homogeneous Gaussian random field and the Green function is assumed to satisfy either Dirichlet or Neumann boundary condition at the random surface as well as the radiation condition at infinity. The Green function is composed of the primary and the secondary part. The latter representing the scattered wave due to the random surface consists of the coherent part and the incoherent part which is expressible as a stochastic integral.

Once the Green function is obtained as a stochastic functional, the dipole, multipole and beam radiation are easily derivable from it and any statistical characteristics associated with the radiation and propagation problem over random surface can be calculated. We first evaluate by the saddle-point method the asymptotic wave field far from the source and the random surface, from which we obtain the angular distributions of the coherent and incoherent radiation, and their dependence on the height of source and the surface conditions such as the roughness and the correlation length. Similarly we can evaluate the asymptotic field far from the source along the surface, from which we obtain the propagation characteristics over the random surface; such as the decay rate against propagation distance, the phase and amplitude distribution of the coherent wave along the height, incoherent power distribution along the height, etc.. It is shown that there is a remarkable difference in the propagation characteristics between the Dirichlet and the Neumann condition of the boundary surface. The numerical calculation of various characteristics is performed assuming the power spectrum of Gaussian form, and numerical accuracy of the approximate solution so obtained is checked using the optical theorem or the conservation law existing between the coherent and the incoherent power flow, which can be derived rigorously.

ON THE SECOND ORDER DOPPLER RETURN FROM AN OCEAN SURFACE

J. Walsh and S.K. Srivastava
Faculty of Engineering and Applied Science
Memorial University of Newfoundland
St. John's, Newfoundland, Canada, A1B 3X5

Many investigators have used the classical Rice perturbation technique for the analysis of EM scattering from rough surfaces. By utilizing this method Barrick (D.E. Barrick in Remote sensing of troposphere, V.E. Derr ed., U.S. Govt. Printing, pp 12.1-12.45, 1972) has derived the average first and second orders of the doppler spectrum return from the ocean surface. In a different approach the authors have developed an analytical technique for dealing with the problem of rough surface scattering (i. J. Walsh, O.E.I.C. report #N00242, Memorial University of Newfoundland, Canada, 200 pp, 1980, and ii. S.K. Srivastava and J. Walsh, Digest IEEE/AP-S international symposium, Houston, pp 680-683, 1983). By applying this technique to the ocean surface expressions for the average first and second orders of the backscattered doppler spectrum at HF have been derived. The ocean surface is modelled as statistically rough in the sense of Rice. The source is assumed to be elementary vertical dipole having a periodic pulsed sinusoidal excitation instead of the plane wave incidence assumed in the perturbation method. The receiving antenna is taken to be a narrow beam one. The result obtained for the first order is the same as derived by Barrick whereas this is not so for the second order. The result contains two additional terms other than that obtained by him. The effects of the additional terms are very pronounced at the higher doppler frequencies. These differences may be traced to the use of a dipole source in the model. The additional second order power results from surface and incident field interaction along the path from transmitter to primary ocean scattering patch and off-patch double scatter. This power may be viewed as additional system noise in the problem of estimating ocean surface parameters from HF radar return.

URSI/B-5-8

A COMPARISON OF A DIFFRACTION MODEL WITH A DIFFUSE SURFACE SCATTERING MODEL IN A BISTATIC GEOMETRY

Robert J. Papa
John F. Lennon
Richard L. Taylor
Electromagnetic Sciences Division
Rome Air Development Center
Hanscom AFB, MA 01731

The problem of scattering of electromagnetic waves by a surface is an important concern for several applications. A number of researchers (Brown, Bahar) have been concerned with determining the diffuse and specular power scattered by the rough surface and received by an antenna system. Other workers (Meeks, Longley-Rice) have concentrated on representing the effects on the system as a diffraction phenomenon. In this paper, a simple bistatic geometry will be considered and comparisons will be made between results obtained by both methods. The major thrust is to determine those conditions for which the diffuse rough surface effects become significant.

The surface between the transmitter and receiver is considered to be a rough surface with a vertical knife-edge obstruction at some point. Different degrees of local roughness are assumed. The position of the obstruction point, the height of the obstruction, and the heights and separations of the two antennas are varied.

In the diffraction model the surface is considered to reflect rays like a mirror, with the reflected rays modified by multiplication with a reflection coefficient term. The direct wave and the waves reflected from the surface combine to form some interference pattern.

The rough surface scattering approach uses a physical optics model with a single scale of surface roughness. Specular and diffuse scattered power contributions are determined. The surface is characterized statistically in terms of height distribution, degree of roughness, and correlation. The surface also is assigned a dielectric constant representing surface features and moisture content. Global and local shadowing effects are included in the analysis.

The diffuse surface scattering is then compared with the power from the diffraction solution. The results are examined as a function of the obstruction and the surface characteristics. The effect of angle of incidence and the frequency dependence are particularly stressed.

THE RENORMALIZED WAVE-INTEGRAL EQUATION AND APPLICATIONS

David A. de Wolf
Department of Electrical Engineering
VPI & SU
Blacksburg, Virginia 24061

Wave propagation in random media with weak fluctuations of the permittivity on a scale large compared to the wavelength is altered chiefly by cumulative forward scatter of EM energy. In discrete random media similar behavior occurs when the average particle size is large compared to the wavelength. When that is not the case, then larger-angle scattering can occur. However, coherence effects at two receivers close to each other are still largely determined by small-angle scattering. For these reasons a renormalization of the wave-integral equation, which separates small-angle from large-angle scattering, is useful. A first-order application of such a renormalization was discussed more than a decade ago (D. A. de Wolf, IEEE Trans. AP-19, 254-262, 1971) in connection with backscatter from a random continuum.

Two further applications are discussed. The renormalization yields an integral expression for large-angle scattering in random media that is useful for collections of large particles and can be applied more generally to bistatic coherence calculations. In another old calculation of the cross-polarized backscatter in such media, the renormalized equation yields correction factors to the integral expressions of the cross section for this effect. Explicit numerical calculations appear to be difficult to carry out. Comparisons to related efforts will be discussed.

URSI/B-5-10

A STUDY OF BACKSCATTERING AND EMISSION FROM CLOSELY PACKED INHOMOGENEOUS MEDIA

A. K. Fung and H. J. Eom
Remote Sensing Laboratory
University of Kansas
Lawrence, Kansas 66045-2969

Abstract

The scattering amplitudes and the associated phase matrix for a small sphere were derived to include near-field effects. Such a phase matrix was then used with the radiative transfer theory to model the scattering and emission from a densely populated inhomogeneous layer without boundaries. Computed results were compared with those obtained when the phase matrix was specialized to the far-field condition. It was found that the use of the far-zone condition tended to underestimate the level of the co-polarized backscattering and to overestimate that of the cross-polarized backscattering. In emission computations, the use of the far-zone condition overestimated the level of the brightness temperature. These effects decreased with a decrease in the volume fraction or an increase in the exploring frequency, as expected.



**URSI COMMISSION B
HALF SESSION B-6**



**CAD-ORIENTED FIELD AND
NETWORK ANALYSIS**

Monday, June 25 1:30 - 3:10 P.M.

Room: ST. GEORGE A, B

Chairman: Tatsuo Itoh

University of Texas at Austin

1. CAD-ORIENTED FIELD AND NETWORK ANALYSIS - Overview, T. Itoh, Department of Electrical Engineering, The University of Texas, Austin, Texas.

2. PLANAR TRANSMISSION LINES, William J. Getsinger, Microwave Consultant, Bethesda, MD.

3. PLANAR CIRCUIT APPROACH, Roberto Sorrentino, Department of Electronics, University of Rome, Rome, Italy.

4. CAD ORIENTED MICROSTRIP DISCONTINUITIES CHARACTERIZATION, K. C. Gupta, Department of Electrical and Computer Engineering, University of Colorado, Boulder, Colorado.

5. CAD ORIENTED FILTER DESIGN, Yi-Chi Shih, Electrical Engineering Department, Naval Postgraduate School, Monterey, California.

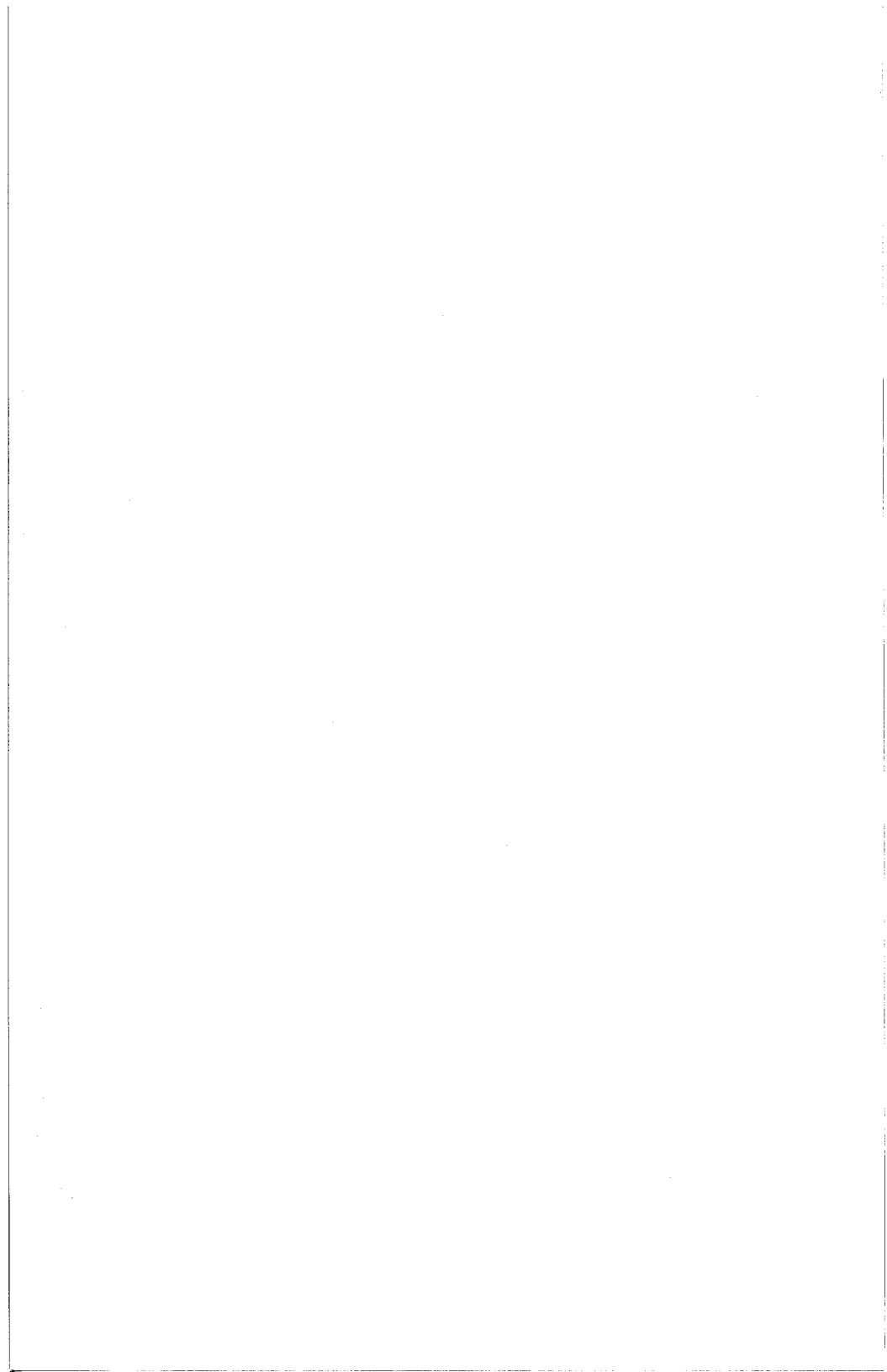

CAD-Oriented Field and Network Analysis - Overview

T. Itoh
Dept. of Electrical Engineering
The University of Texas
Austin, TX 78712

As the microwave integrated circuits become more sophisticated and the monolithic circuit approaches are introduced, the computer-aided circuit design becomes indispensable. Many practicing engineers like to have simple closed form expressions, often obtained by curve fitting, for the propagation constants, impedances, and scattering parameters. It is important that these formulas have to be supported by the best possible analytical efforts. Understanding of the limitations, accuracy and usefulness of these formulas is the key for successful circuit design. Such understanding is obtained only if the theoretical background is well explored.

This session contains several papers dealing with theoretical efforts toward developing reliable CAD techniques. The first paper identifies some typical structures for which accurate CAD's are accurately needed. Next, the paper discusses briefly the available analytical techniques for these problems with their limitations.

URSI/B-6-2

PLANAR TRANSMISSION LINES

William J. Getsinger
Microwave Consultant
Bethesda, MD 20817

Transmission lines are the basic space-spanning elements of which microwave circuits are made. Planar transmission lines are used for most present-day microwave circuits because of their many advantages: small size, low cost in quantity, accuracy in reproduction, reliability, and convenient open surface on which lumped elements can be added. Microstrip, coplanar waveguide, twin-strip, slot line and finline are all planar lines, but microstrip has been the most widely used. It consists of a dielectric slab metallized on one side for a ground plane, and having the microwave circuit printed by photolithography on the other side.

This paper will describe the most popular mathematical techniques for finding the propagation constant of microstrip and other planar lines. The critical point is that planar lines have inhomogeneous dielectrics, and so propagation can be described rigorously only in terms of infinite summations of hybrid E and H modes; nevertheless, for computer aided circuit design, the lines must be treated as TEM lines. This quasi-TEM assumption will be discussed.

The three major categories of analysis are static, (Laplace's equation) dynamic (Helmholtz wave equation) and approximate. The complexity of the problem implies that the first two categories can be solved only by computer-oriented techniques. Some methods from all three categories will be presented.

Circuit design is based on Kirchoff's equations and the assumptions of the existence of voltages and currents associated with terminals. Voltage and current cannot be defined uniquely for hybrid-mode structures, such as planar transmission lines and so they do not have unique definitions of characteristic impedance (except possibly at zero frequency). However, planar lines are used in actual circuits and they appear to have unique characteristic impedances. The concept of apparent characteristic impedance, and possible definitions for it will be discussed.

Planar Circuit Approach

Roberto Sorrentino
University of Rome
Dept. of Electronics
Rome, Italy

As ever higher frequency ranges are used, both the longitudinal and transverse dimensions of microwave integrated circuits and components become comparable with the signal wavelength. In such cases, simple one dimensional transmission line models can hardly be applied to the analysis of integrated circuit structures, and a planar, i.e. two-dimensional, approach is required. Such an approach is not only useful to characterize accurately the performances of integrated circuits, but also makes it possible to take advantage of at least one more degree of freedom in the design of some specific integrated components.

Planar circuit techniques are presented and discussed together with their advantages and limitations. The physical interpretation of the filtering properties of planar structures is illustrated on the basis of theoretical as well as specific experimental analyses.

Applications of the planar circuit approach to the analysis and design of MIC's are presented.

URSI/B-6-4

CAD ORIENTED MICROSTRIP DISCONTINUITIES CHARACTERIZATION

K.C. Gupta
Department of Electrical and Computer Engineering
University of Colorado
Boulder, Colorado 80309

Characterization of microstrip discontinuities is a necessary step in successful design of microwave integrated circuits. This is usually accomplished by using equivalent lumped element models for various discontinuities, the various parameters for these models having been obtained from quasistatic evaluations of discontinuity capacitances and inductances. This approach embodies two possible disadvantages: accurate models are available only for a limited set of discontinuity configurations and parameters, and accuracies of lumped element models degrade at higher frequencies.

An alternative approach for discontinuities characterization is based on two-dimensional analysis using Green's functions and segmentation method. This approach employs planar models for the discontinuity region and short sections of connected transmission lines. This planar model is divided into rectangular (and/or triangular) segments for which two-dimensional impedance Green's functions are known. Impedance matrices of each of these segments are computed and combined by segmentation method to obtain the impedance matrix of the overall network (discontinuity configuration plus short sections of connected transmission lines). This impedance matrix is transformed into S-matrix which is modified to compensate for the effect of lengths of connected lines. S-matrix of the discontinuity configuration can now be returned to the circuit analysis program.

Details of this approach for discontinuity characterization would be discussed.

CAD ORIENTED FILTER DESIGN

Yi-Chi Shih
Naval Postgraduate School
Electrical Engineering Department
Monterey, California 93943

To date, a computer-aided design (CAD) is an essential tool for obtaining a circuit giving the required performance with reduced cost. Two approaches, network synthesis and optimization, are generally used in the CAD-oriented filter design. In both cases, the key to a successful CAD procedure is the availability of a rigorous analysis for the filter structure.

The conventional network synthesis is an efficient technique. In this approach a lowpass filter prototype in forms of a lumped circuit, distributed circuit, or mixed lumped-distributed circuit is used. With a given filter specification the values of the elements in the prototype are calculated. The resulting prototype circuit is then converted to physical filter structure. It is the final conversion that requires a rigorous analysis of the physical structure.

In the optimization process an analysis program is always required to calculate the frequency response of a filter structure for a given set of dimensions. The optimization routine is then systematically adjusting the filter dimensions until its calculated performance satisfies the specifications. It is obvious that this process is time-consuming because of the large number of iterations involved.

The synthesis technique is more favorable for its efficiency; however, it is an approximate procedure for microwave filter design. Problems may occur due to the higher-order mode coupling between the discontinuities and due to the inaccurate frequency behavior of the lumped elements which represent the discontinuities. These factors normally result in a filter performance having a narrower bandwidth and a lower center frequency. Nevertheless, the filter synthesized can always serve as a good initial guess for an efficient optimization procedure that gives accurate results.

Successful design examples, including E-plane filters and evanescent-mode waveguide dielectric-resonator filters, will be presented. Because of the rigorous analysis, the filters are constructed with predicted performances without laborious fine-tuning.



**URSI COMMISSION B
HALF SESSION B-7
GUIDED WAVES**



Monday, June 25 3:20 - 5:00 P.M.

Room: ST. GEORGE A, B

Chairman: James W. Mink

U.S. Army Research Office,

Research Triangle Park, N.C.

6. DISPERSION RELATIONS FOR ANISOTROPIC WAVEGUIDES, R. D. Graglia and P. L. E. Uslenghi, Department of Electrical Engineering and Computer Science, University of Illinois, Chicago, IL

7. UNIFIED INTEGRAL-OPERATOR DESCRIPTION FOR THE COMPLETE MODAL SPECTRUM OF INTEGRATED DIELECTRIC WAVEGUIDES, J. S. Bagby and D. P. Nyquist, Department of Electrical Engineering and Systems Science, Michigan State University, East Lansing, MI

8. WAVEGUIDE IRIS PROBLEMS: A GENERALIZED DUAL SERIES AP-

PROACH, J. Brian Grant and Richard W. Ziolkowski, Lawrence Livermore National Laboratory, Electronics Engineering Department, Livermore, CA

9. EXCITATION OF HELICAL STRUCTURES, Paul R. McIsaac, School of Electrical Engineering, Cornell University, Ithaca, NY

10. APPROXIMATE SOLUTIONS FOR REFLECTION FROM AN OPEN-ENDED WAVEGUIDE, S. L. Chuang and S. W. Lee, University of Illinois, Urbana, IL, Y. C. Cho, NASA Lewis Research Center, Cleveland, OH

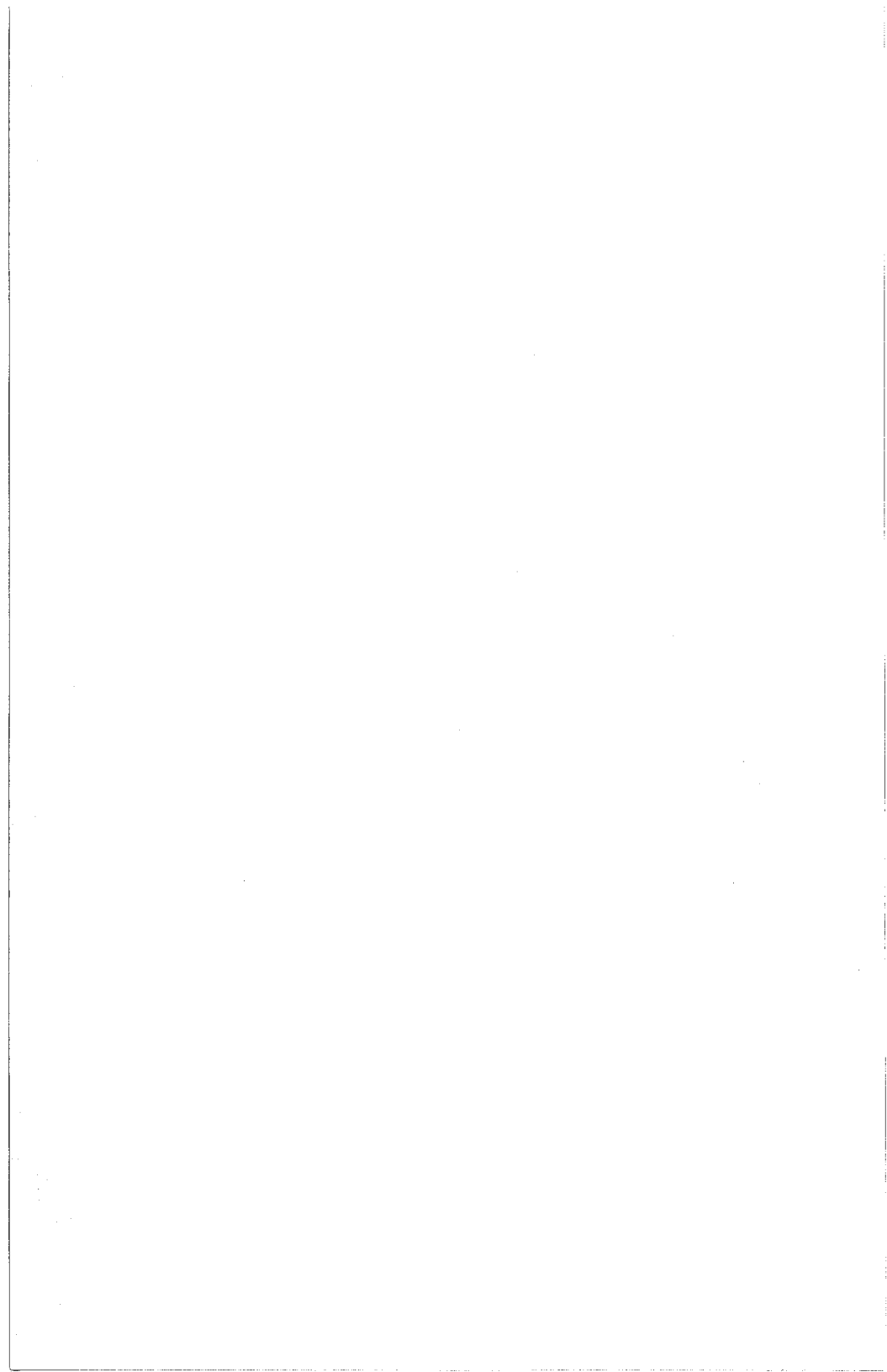

DISPERSION RELATIONS FOR ANISOTROPIC WAVEGUIDES

R.D. Graglia and P.L.E. Uslenghi
 Department of Electrical Engineering and Computer Science
 University of Illinois, Chicago, IL 60680

In a medium characterized by a complex electric susceptibility tensor $\bar{\chi}_{ec}$ and a magnetic susceptibility tensor $\bar{\chi}_m$, it is convenient to introduce the fields $(\underline{e}, \underline{h})$ related to the electric and magnetic fields $(\underline{E}, \underline{H})$ by

$$(1) \quad \underline{e} = \bar{\chi}_{ec} \underline{E} \quad , \quad \underline{h} = Z_0 \bar{\chi}_m \underline{H} \quad ,$$

where Z_0 is the intrinsic impedance of free space. For propagation along anisotropic waveguides oriented in the z direction, we let

$$(2) \quad \underline{e}(\underline{r}) = \underline{\mathcal{E}}(\underline{\rho}) \exp(-j\beta z) \quad , \quad \underline{h}(\underline{r}) = \underline{\mathcal{H}}(\underline{\rho}) \exp(-j\beta z) \quad ,$$

where $\underline{\rho}$ is the position of the observation point in a plane $z = \text{constant}$. The fields $\underline{\mathcal{E}}$ and $\underline{\mathcal{H}}$ satisfy the system

$$(3) \quad T_1(\underline{\mathcal{E}}, \underline{\mathcal{H}}) = 0 \quad , \quad T_2(\underline{\mathcal{E}}, \underline{\mathcal{H}}) = 0 \quad ,$$

where the integro-differential operators $T_{1,2}$ were given previously (R.D. Graglia and P.L.E. Uslenghi, National Radio Science Meeting, Houston, TX, May 1983; R.D. Graglia, Doctoral Thesis, University of Illinois at Chicago, November 1983). In matrix form, $(\underline{\mathcal{E}}, \underline{\mathcal{H}})$ may be considered as a six-element column vector and eq. (3) rewritten as:

$$(4) \quad \begin{bmatrix} \bar{T}_1 \\ \bar{T}_2 \end{bmatrix} \begin{bmatrix} \underline{\mathcal{E}} \\ \underline{\mathcal{H}} \end{bmatrix} = \bar{T} \begin{bmatrix} \underline{\mathcal{E}} \\ \underline{\mathcal{H}} \end{bmatrix} = 0 \quad .$$

For nontrivial solutions, the determinant of the matrix \bar{T} must be zero. This condition determines the dispersion relation $\beta(k_0)$, where k_0 is the wavenumber in free space.

From a numerical viewpoint, when an adequate approximation to the fields $\underline{\mathcal{E}}, \underline{\mathcal{H}}$ is achieved,

$$(5) \quad | \det \bar{T} | = \min \quad .$$

Thus, the propagating modes for a given cylindrical structure are found by considering the absolute value of the determinant of the matrix \bar{T} as a functional to be minimized. The points of the (β, k_0) plane (where β may be complex) corresponding to a minimum describe the dispersion diagram of the structure.

We have developed an optimization program able to reduce the number of times that we have to compute $| \det \bar{T} |$, and to find the dispersion diagram point by point. Several examples of anisotropic guides are discussed in detail.

URSI/B-7-7

UNIFIED INTEGRAL-OPERATOR DESCRIPTION FOR THE COMPLETE MODAL SPECTRUM OF INTEGRATED DIELECTRIC WAVEGUIDES

J.S. Bagby and D.P. Nyquist

Department of Electrical Engineering and Systems Science
Michigan State University, East Lansing, Michigan 48824

A polarization, electric-field integral equation (EFIE) formulation is presented for field $\vec{E}(\vec{\rho}, z)$ excited along an integrated dielectric waveguide by impressed radiation $\vec{E}^i(\vec{\rho}, z)$ ($\vec{\rho}$ =transverse position vector, z =axial coordinate); it provides a unified, conceptually-exact description for the complete propagation-mode spectrum supported by a graded-index guide of any cross-section shape. The open system consists of a graded guiding-core region of refractive index $n(\vec{\rho})$ embedded in a cladding overlay of index n_c adjacent to a film layer of index n_f deposited on a substrate of index n_s with $n_s > (n_c, n_f)$. Index contrast $\delta n^2 = n_c^2 - n_s^2$ is non-vanishing over core cross section CS. An exact differential-operator analysis is precluded by the inseparable boundary conditions; approximate surface-wave solutions have been advanced, while the radiation field has not been treated. The integral-operator formulation provides, through the EFIE for unknown \vec{E} in the guiding region, a unified description of both discrete surface-wave and continuous radiation-field components of the propagation-mode spectrum.

If the EFIE for \vec{E} excited in the axially-invariant guiding region by \vec{E}^i is Fourier transformed on the axial variable, it leads to

$$\vec{e}(\vec{\rho}, \zeta) - (n_c^2 k_0^2 + \nabla \cdot \nabla) \int_{CS} \frac{\delta n^2(\vec{\rho}')}{n_c^2} \vec{g}_{\zeta}(\vec{\rho} | \vec{\rho}') \cdot \vec{e}(\vec{\rho}', \zeta) dS' = \vec{e}^i(\vec{\rho}, \zeta) \quad \text{for all } \vec{\rho} \in CS$$

where ζ =transform variable, k_0 =free-space wavenumber and $\nabla = \nabla_{\vec{\rho}} + \hat{z} j \zeta$ while transform pairs are $\vec{E} \leftrightarrow \vec{e}$ and $\vec{g}_{\zeta}(\vec{\rho} | \vec{\rho}') = \mathcal{F}\{\vec{G}(\vec{\rho} | \vec{\rho}'; z)\}$ with \vec{G} the electric Green's dyadic for the tri-layered media. Components of \vec{g}_{ζ} are given by Sommerfeld-integral representations.

In considering the Fourier inversion of $\vec{e}(\vec{\rho}, \zeta)$ to $\vec{E}(\vec{\rho}, z)$, deformation of the inversion contour with subsequent ζ -plane analysis leads to surface-wave modes as residues at simple-pole singularities $\zeta = \pm \beta$ of $\vec{e}(\vec{\rho}, \zeta)$ while the continuous radiation-mode spectrum arises from integrals along the branch cuts of \vec{g}_{ζ} . Natural surface-wave modes are those non-trivial homogeneous solutions to the transform-domain EFIE which occur when its left side vanishes at singularity points $\zeta = \pm \beta$. A spectral component of the radiation field is that forced EFIE solution excited by $\vec{e}^i(\vec{\rho}, \zeta)$ for points ζ along the relevant branch cuts. This integral-operator treatment leads naturally to an excitation theory for such waveguides.

WAVEGUIDE IRIS PROBLEMS: A GENERALIZED DUAL SERIES APPROACH

J. Brian Grant and Richard W. Ziolkowski

Lawrence Livermore National Laboratory
Electronics Engineering Department
P. O. Box 5504, L-156, Livermore, CA 94550*

A general method will be presented for the analysis of waveguide iris problems. It is based upon the generalized N-series approach [R. W. Ziolkowski, UCRL-88906, 1983 (to appear in SIAM J. Math. Anal.)] which recently has been employed successfully in aperture coupling problems [R. W. Ziolkowski, W. A. Johnson and K. F. Casey, UCRL-88169, 1983 (Proceedings, 1983 URSI Santiago Symposium)]. The method is essentially analytical in nature.

In particular, the problems of a capacitive and an inductive thin iris in a rectangular waveguide will be considered. Their generalized dual series solutions readily yield the currents on the iris and the field structure near the edge of the iris. It can be shown analytically that the fields and currents satisfy the Meixner edge conditions. Moreover, these analytic results are utilized to avoid slow convergence problems near the edge of the iris. Examples will be given to illustrate the behavior of the solutions as functions of the wavelength and the size of the iris.

*This work was performed by the Lawrence Livermore National Laboratory under the auspices of the U.S. Department of Energy under contract W-7405-ENG-48.

EXCITATION OF HELICAL STRUCTURES

Paul R. McIsaac
School of Electrical Engineering
Cornell University
Ithaca, NY 14853

Collin has discussed the excitation of the modes in closed-boundary waveguides and the surface waves in open-boundary waveguides by an arbitrary filamentary current (R. E. Collin, Field Theory of Guided Waves. New York: McGraw-Hill, 1960, sections 5.6 and 11.7). This discussion is based on representing the fields by a normal mode expansion. However, the results reported apply only to structures which have reflection symmetry in a plane perpendicular to the waveguide axis. These results are not valid for helical structures, an important class of waveguides. In this paper, the mode excitation produced by a filamentary current is derived using a normal mode expansion for helical structures. These possess 180° rotation symmetry about an axis perpendicular to the waveguide axis; they do not have reflection symmetry.

The orthogonality relations for waveguides with 180° rotation symmetry are stated (these differ from those for waveguides with reflection symmetry). Then the mode coefficients are derived when the excitation is an arbitrary filamentary current. These results are developed for general waveguide terminations which may produce intermode coupling between the incident and reflected waves.

The general results are illustrated by applying them to an unshielded sheath helix. The surface waves of this structure vary as $\exp(jp\theta)$, $-\infty < p < \infty$; each integer p value labels one of the surface waves in the infinite set. The connection between the orientation and geometry of the filamentary source current and the subset of surface waves excited is explored. Also considered is the effect of the terminations at either end of the helix. Of course, the solution to the filamentary source current problem can be used to construct solutions for source currents with arbitrary spatial distributions.

As a further illustration, the excitation of the surface waves on a sheath helix supported by three dielectric rods is briefly examined. In this case, the infinite set of surface waves form three classes. The criteria for exciting surface waves in each of these three classes by the source current are determined.

APPROXIMATE SOLUTIONS FOR REFLECTION FROM AN OPEN-ENDED WAVEGUIDE

S. L. Chuang and S. W. Lee
University of Illinois
Urbana, Illinois 61801

Y. C. Cho
NASA Lewis Res. Center
Cleveland, Ohio 44135

Approximate analytic methods are introduced for the study of electromagnetic wave reflected from the open end of a waveguide. Two methods are proposed. The first is based on a statistical theory for sound radiation and reflection from a duct from the point of view of phonons (Y. C. Cho, J. Acoust. Soc. Am., 65, 1373, 1979). Simple reflection formula could also be derived for the electromagnetic case. The results compare reasonably well with the exact solution (L. A. Weinstein, The Theory of Diffraction and the Factorization Method, 1969) for the magnitude of the reflection coefficient but not the phase which is zero using the statistical theory of quasi-particles.

The second method is an approximation from the exact mode-matching technique, taking into account the fact that the reflection coefficients are small and thus only the leading order term is important. The results for the reflection coefficients including their phases are improved compared with the first method.

We have also formulated the exact mode matching technique with numerical results to compare with the previous two methods. All these results are checked with the exact solutions using the Wiener-Hopf technique or the Ray-optical analysis (J. Boersma, Proc. IEEE, 62, 1475, 1974).

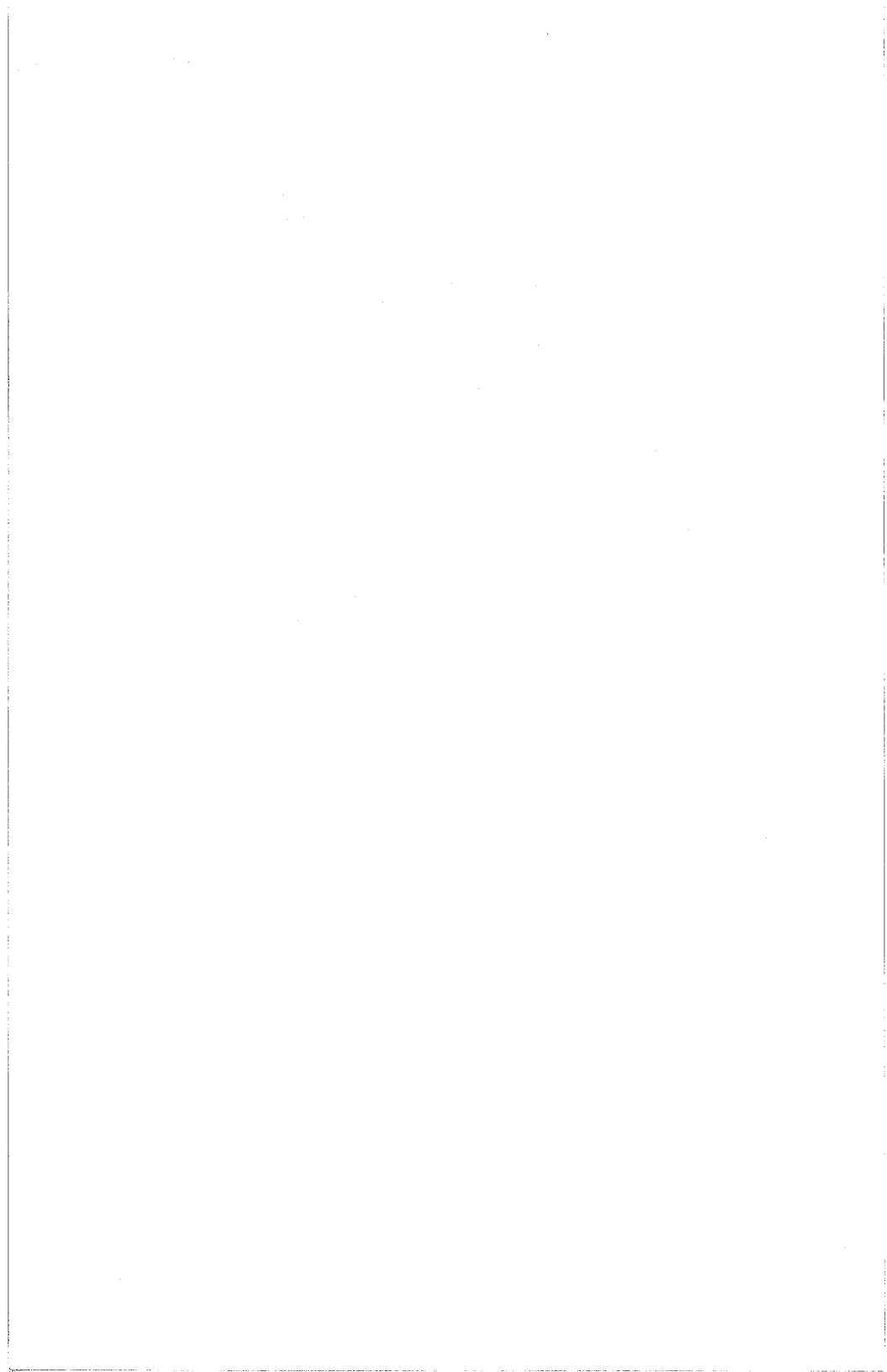

**URSI COMMISSION B SESSION B-8
TRANSIENTS/NUMERICAL METHODS
Tuesday, June 26 8:30 A.M. - 12:00 NOON**

 **Room: ESSEX NORTH WEST** 

**Chairman: C. Leonard Bennett
Raytheon Company, Marlboro, MA**

1. POINT-MATCHED TIME DOMAIN FINITE ELEMENT METHODS, A. C. Cangellaris, C. C. Lin and K.K. Mei, Department of Electrical Engineering and Computer Sciences and the Electronics Research Laboratory, University of California, Berkeley, CA

2. RELATIONSHIP OF TRAVELING WAVES AND TOTAL DOMAIN GALERKIN EXPANSIONS, L. N. Medgyesi-Mitschang and J. M. Putnam, McDonnell Douglas Research Laboratories, St. Louis, MO

3. EXTENDED EXPANSION TECHNIQUE FOR SOLVING SCATTERING PROBLEMS INVOLVING COUPLED RESONANT SUBSTRUCTURES, Karl S. Kunz, Lawrence Livermore National Laboratory, Livermore, CA

4. HYBRID TECHNIQUE FOR MODELING THE RADAR CROSS SECTION OF VERY LARGE OBJECTS, Korada R. Umashankar and Allen Taflove, Applied Electromagnetic Technology, Electronics Department, IIT Research Institute, Chicago, IL

5. VALIDATION OF FD-TD MODELING OF THE RADAR CROSS SECTION OF THREE-DIMENSIONAL STRUCTURES

SPANNING UP TO 9 WAVELENGTHS, Allen Taflove, Korada R. Umashankar, and Thomas G. Jurgens, Applied Electromagnetic Technology, Electronics Department, IIT Research Institute, Chicago, IL

6. PROFILE INVERSION BY METHOD OF CHARACTERISTICS IN A LOSSY, CYLINDRICAL MEDIUM, A. Sezginer, Department of Electrical Engineering and Computer Science and Research Laboratory of Electronics Massachusetts Institute of Technology, Cambridge, MA

7. NUMERICALLY DETERMINED NATURAL RESONANCES FOR AN INFINITELY LONG PERFECTLY CONDUCTING STRIP, Shain-Uei Hwu and L. Wilson Pearson, Department of Electrical Engineering, University of Mississippi, University, MS

8. IMPULSE TIME DOMAIN REFLECTOMETRY AS A DIAGNOSTIC TOOL FOR ANTENNA SCATTERING STUDY, Jonathan D. Young and William Leeper, The Ohio State University ElectroScience Laboratory, Columbus, OH

9. IMPROVED FORMULATION FOR FOCUS WAVE MODES-T.E., J. N. Brittingham, Lawrence Livermore National Laboratory, Livermore, CA

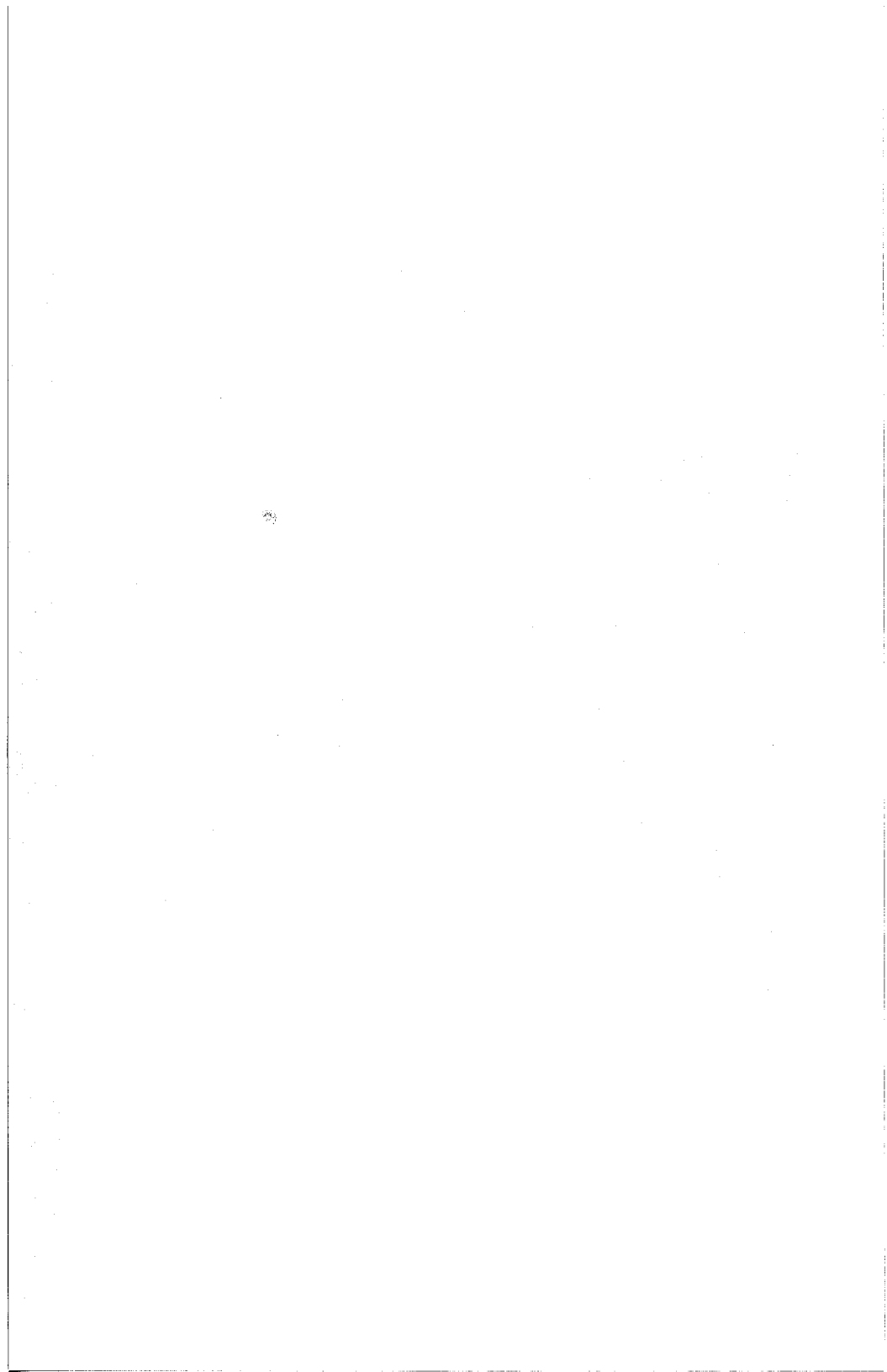

POINT-MATCHED TIME DOMAIN FINITE ELEMENT METHODS

A.C. Cangellaris, C.C. Lin and K.K. Mei

Department of Electrical Engineering and Computer Sciences and the Electronics Research Laboratory, University of California, Berkeley, CA94720.

Present generation of computers offer great memory capabilities, which favor the computational methods that demand large memories yet require no matrix inversion. Time domain techniques appear to be a class of such methods. Conventional time domain finite difference (TDFD) methods have the disadvantage of restricted discretization capability, and the conventional time domain finite element method still has the need to invert large size matrices prior to the time integration. This paper presents techniques which have general capability of conforming meshes without matrix inversion. Our earlier work (Mei et al, Int. URSI Symp., 1983) has already demonstrated the feasibility of such schemes. Recent development in point-matched finite element and boundary element techniques have further advanced the art so as to reduce memory demands and computational time and yet, still preserve the computational integrities of finite element methods. The applications of the present methods to scattering and radiation problems are described step by step together with a few representative results in two dimension and three dimension with axial symmetry.

URSI/B-8-2

RELATIONSHIP OF TRAVELING WAVES AND TOTAL DOMAIN GALERKIN EXPANSIONS

L. N. Medgyesi-Mitschang and J. M. Putnam
McDonnell Douglas Research Laboratories
St. Louis, MO 63166

Traveling waves on classes of electrically extended conducting bodies are constructed using selected elements of total domain Galerkin expansion sets. In this analysis, the electric field integral equation formulation is used. A criterion, related to the characteristic dimensions of the body, is developed for choosing these elements. This representation allows rapid evaluation of the traveling waves on a broad class of non-canonic scatterers. Specific examples are worked out for one-, two-, and three-dimensional geometries. Numerical results are presented to show the convergence properties of this approach as a function of scatterer dimensions and surface characteristics such as curvature. Comparisons are made with published results using alternate analytical methods.

EXTENDED EXPANSION TECHNIQUE FOR SOLVING SCATTERING PROBLEMS
INVOLVING COUPLED RESONANT SUBSTRUCTURES*

Karl S. Kunz

Lawrence Livermore National Laboratory
P. O. Box 5504, L-153, Livermore, California 94550Abstract

Time domain finite difference codes represent an effective approach to solving EM scattering problems in the resonance region. When frequencies well above the resonance region of the scattering object are involved, as when the object is a ship which includes many substructures, as small as an antenna on a mast, that also resonant, but at a much higher frequency, only the largest computers and very long run times permit a solution using the finite difference approach.

A more efficient approach in this case is to use the expansion technique (Kunz and Simpson, EMC-23, 419-422, 1981) to regrid a portion of the problem space about which tangential electric fields are stored and rerun this portion of the problem space to obtain the local high frequency response, say of the antenna on a mast, while retaining the low frequency response, in this case the rest of the ship. Regridding, for example, four times finer in the subregion costs four times the coarse gridded run because of the increased number of times steps for a total increase in cost of a factor of five compared to the brute force approach of more finely gridding everywhere which would cost sixty four times as much.

The expansion technique approach does not allow for the interaction of multiple substructures that are not close enough to place in a single subvolume that is to be regridded. This case can be treated by extending the expansion technique to include multiple, physically separate subvolumes. The response of the enclosed objects, antennas, for example, are then found on the finely gridded run as determined by their own structure and the low frequency effects of their surroundings minus the other substructures. The coarsely gridded run is then repeated using the scattered fields on or immediately about the substructures as a constraint. Then the finely gridded runs are repeated using tangential electric fields on the subvolumes that now include the other substructures' effects. In this fashion the coupling between the substructures can be modeled over the lower frequency limit set by the coarser gridded run. The second set of runs increases cost by a factor of two so the extended expansion technique remains economical while providing coupling information over the frequencies of most interest when the substructures are widely separated.

*Work performed under the auspices of the U. S. Department of Energy by the Lawrence Livermore National Laboratory under Contract Number W-7405-ENG-48.

URSI/B-8-4

HYBRID TECHNIQUE FOR MODELING THE RADAR CROSS SECTION OF VERY LARGE OBJECTS

Korada R. Umashankar and Allen Taflove
Applied Electromagnetic Technology
Electronics Department
IIT Research Institute
Chicago, Illinois 60616

The present method of moments (MOM) is basically applicable to model the radar cross section of three-dimensional objects having sizes up to approximately 1 wavelength. Similarly, the existing finite-difference time-domain (FD-TD) technique is applicable for modeling objects up to approximately 10 wavelengths. For electrically very large objects, especially those that are made of dielectric media as well as metal, it would be desirable to develop some means to extend existing MOM and FD-TD approaches in a natural way for purposes of modeling radar cross section.

An efficient hybrid technique has been developed utilizing high-frequency principles based on equivalent currents. This approach differs from previous hybrid methods in that the high-frequency information is not obtained via GTD coefficients. This paper presents numerical results of the new hybrid technique in modeling the monostatic radar cross section of electrically very large two-dimensional dielectric objects.

VALIDATION OF FD-TD MODELING OF THE RADAR CROSS SECTION
OF THREE-DIMENSIONAL STRUCTURES SPANNING UP TO 9 WAVELENGTHS

Allen Taflove, Korada R. Umashankar, and Thomas G. Jurgens
Applied Electromagnetic Technology
Electronics Department
IIT Research Institute
Chicago, Illinois 60616

This paper reports the experimental validation of the finite-difference time-domain (FD-TD) method for modeling the monostatic radar cross section of three-dimensional conducting structures spanning up to 9 wavelengths ($k_s = 57$). This represents a 30-fold increase in electrical size over the previous validated case of FD-TD modeling of radar cross section. The authors believe that the cases studied represent the largest detailed radar cross section models (0.1 wavelength spatial resolution in all dimensions) ever presented.

Three canonical structures were modeled: (1) Flat Plate, 30 cm x 10 cm x 0.65 cm; (2) Crossed-Plate (T), 30 cm x 10 cm x 0.33 cm (main plate) and 10 cm x 10 cm x 0.33 cm (bisecting plate); and (3) Hollow Square Cylinder, 30 cm x 10 cm x 10 cm with 0.33 cm thick walls. Experimental data for radar cross section were obtained from 1 GHz to 9 GHz at the calibrated anechoic chamber facility operated by SRI International, Menlo Park, CA.

Numerical and experimental results are presented which indicate that the FD-TD approach provides radar cross section predictions accurate to 1 dB over at least a 40 dB dynamic range (ratio of maximum radar cross section feature to minimum feature for a single scatterer). The required computer time per look angle is 12 - 24 minutes (Cray-1S) or 4 - 8 minutes (Cray X-MP), with the range of times representing the possible optimizations.

Last, this paper will briefly touch on the implications of supercomputer development for FD-TD modeling of large scatterers. A preliminary software package for the Cray X-MP has been constructed which points toward 30-minute running times for looks at 20-wavelength scale models. Next-generation supercomputers should permit substantially larger FD-TD models with running times in this range.

PROFILE INVERSION BY METHOD OF CHARACTERISTICS
IN A LOSSY, CYLINDRICAL MEDIUM.

A. Sezginer

Department of Electrical Engineering and Computer Science
and Research Laboratory of Electronics
Massachusetts Institute of Technology
Cambridge, Massachusetts 02139

The method of characteristics, which is widely used to solve hyperbolic partial differential equations, can also be used for profile inversion in one space dimension. A lossy, cylindrical medium, that has radially varying wave speed and relaxation time profiles, is treated by the method of characteristics. It is assumed that a known, transient current is impressed on the surface of a magnetically impenetrable cylinder that is coaxial with the radial profile. The transient, axial electric field is assumed to be measured at the surface of the same cylinder. The relaxation time profile is assumed to be known. An algorithm is demonstrated, that propagates the electric field into the medium and solves the speed profile simultaneously.

The algorithm is checked by synthetically generated data. Synthetic data is generated for two problems: step wise changing profile, and a profile with constant relaxation time and linearly changing wave speed. The time-domain data for the latter problem is expressed in closed form.

The method of characteristics is very efficient; inverting 200 points in the profile takes 590 milliseconds on a VAX 780. The algorithm yields accurate results when the input data is precise. Sensitivity of the algorithm to noise in the input data is determined by computational experiments.

**NUMERICALLY DETERMINED NATURAL RESONANCES
FOR AN INFINITELY LONG PERFECTLY CONDUCTING STRIP**

Shain-Wei Hwu and L. Wilson Pearson
Department of Electrical Engineering
University of Mississippi
University, MS 38677

This presentation deals with the singularity expansion resonances of an infinitely long finite-width perfectly conducting strip as determined numerically, using a method of moments scheme. The Laplace domain spectrum of such a structure manifests pole singularities due to reflection of surface currents at the edges of the strip and a branch point by way of the zeroth-order Hankel function, which is the Green's function associated with infinite-extent structures. That the structure is infinite in one dimension results, too, in the segregating of the spectrum into a portion associated with transverse electric field polarization and a portion associated with transverse magnetic polarization.

Another presentation in this meeting deals with the resonances of the strip structure obtained from a geometrical theory of diffraction (GTD) model on which resonance is enforced through a self-consistency condition (Shirai, Heyman, and Felsen). The method of moments results are compared with their results.

for review by Commission B

URSI/B-8-8

IMPULSE TIME DOMAIN REFLECTOMETRY AS A DIAGNOSTIC TOOL FOR ANTENNA SCATTERING STUDY

Jonathan D. Young and William Leeper

The Ohio State University ElectroScience Laboratory
1320 Kinnear Road
Columbus, Ohio 43212

The coherent spectral backscattering of antennas were measured at several discrete look angles over a continuous frequency band from 1.2 to 12 GHz. These data were then Fourier transformed to produce approximate impulse response data. This paper describes the characteristics of such data and relates them to antenna physical features and scattering mechanisms.

First, the measurement process is described. The effort made use of the OSU compact radar range, including coherent stepped-frequency measurements for horizontal, vertical, and cross-polarized scattering of antennas, reference targets, and background.

Approximate impulse waveforms of reference targets and then a set of test antennas are presented. Mechanisms such as edge scattering, specular scattering, cavity scattering, element grating lobes, and sub-array grating lobes are identified in the measured impulse response waveforms. The time domain and frequency domain format for the same data are compared and contrasted.

It is concluded that Scattering Impulse Time Domain Reflectometry provides very broadband scattering information in a way that permits scattering mechanisms to be identified and localized on the antenna structure to great accuracy. Scattering control techniques which are applicable over a wide range of frequencies and look angles tend to result from such a diagnostic process.

IMPROVED FORMULATION FOR FOCUS WAVE MODES-T.E.

J. N. Brittingham
Lawrence Livermore National Laboratory
P.O. Box 808
Livermore, CA 94550

In the preceding paper ("Focus Wave Modes in Homogeneous Maxwell's Equation: Transverse Electrical Mode," J. N. Brittingham, J. Appl. Phys., Vol. 54, No. 3, March 1983, pp. 1179-1189) analytical formulations for three-dimensional, source-free, focused, electromagnetic packet were given. These pulses moved at light velocity. They are truly three-dimensional function because they decrease in the three spatial coordinates away from the moving pulse center. Because of the focused nature, we choose to call them Focus Wave Modes, abbreviated FWM. They are the first three-dimensional solitary solution to homogeneous Maxwell's equations. This formulation contained seven parameteric constants and two supplemental equations which interrelated these quantities. Their asymptotic fields magnitude is similar to those for the stationary free-space dipoles.

In this paper an improved analytical expression for this identical problem is presented. This formulation has four parameters and no supplemental equations. Also the electromagnetic energy of these packets will be discussed. By using a procedure which is used on the stationary dipoles, we can obtain finite-energy solution for both solutions. This approach is to confine the solution-space to volume with finite extent. This procedure also will be demonstrated here.

*Work performed under the auspices of the U.S. Department of Energy by the Lawrence Livermore National Laboratory under contract No. W-7405-ENG-48.



URSI COMMISSION B SESSION B-9
SCATTERING FROM OBJECTS NEAR
MEDIA INTERFACES
Tuesday, June 26 8:30 A.M. - 12:00 NOON
Room: ESSEX NORTH EAST
Chairman: Robert D. Nevels
Texas A & M University, College Station,
TX

1. ELECTROMAGNETIC SCATTERING FROM CONDUCTING OBJECTS IMMERSED IN A DISSIPATIVE HALF-SPACE, Rajeev Bansal, Department of Electrical Engineering and Computer Science, The University of Connecticut, Storrs, CT, R.W.P. King, Gordon McKay Laboratory, Harvard University, Cambridge, MA

2. ON THE SCATTERING OF LATERAL WAVES BY BURIED OR SUBMERGED OBJECTS, Ronald W. P. King, Gordon McKay Laboratory, Harvard University, Cambridge, MA

3. SCATTERING OF A LATERAL ELECTROMAGNETIC WAVE BY A METAL CYLINDER, M. Franklin Brown, Gordon McKay Laboratory, Harvard University, Cambridge, MA

4. CURRENT INDUCED ON A STRIP WHICH EXTENDS THROUGH THE PLANAR INTERFACE BETWEEN TWO SEMI-INFINITE HALF SPACES, Xu Xiao-Bang and Chalmers M. Butler, Department of Electrical Engineering, University of Houston, Houston, TX

5. ON THE DYADIC GREEN'S FUNCTION FOR A GROUNDED DIELECTRIC SLAB, Krzysztof A. Michalski, Department

of Electrical Engineering, University of Mississippi, University, MS

6. GUIDED-MODE LAUNCHING IN A SLAB WAVEGUIDE BY WAY OF DIFFRACTION AT THE EDGE OF A CONDUCTING SCREEN RESIDING ON ONE SURFACE OF THE SLAB, L. Wilson Pearson and Timothy H. Farris, Department of Electrical Engineering, University of Mississippi, University, MS

7. ANALYSIS OF AN ARRAY OF NARROW CONDUCTING STRIPS ON A TWO-MEDIA INTERFACE, Chalmers M. Butler and Anthony Q. Martin, Department of Electrical Engineering, University of Houston, Houston, TX

8. LOW FREQUENCY WAVE IMPEDANCE FOR A SINGLE WIRE ABOVE A HOMOGENEOUS EARTH, Robert G. Olsen, and Daniel Rouseff, Department of Electrical and Computer Engineering, Washington State University, Pullman, WA

9. BEHAVIOR OF RESONANT WIRES AND OF TRANSMISSION LINES VERY NEAR THE EARTH, Peter Hayes, MITRE Corporation, Bedford, MA, Leon Peters, Jr. Department of Electrical Engineering, Ohio State University, Columbus, OH

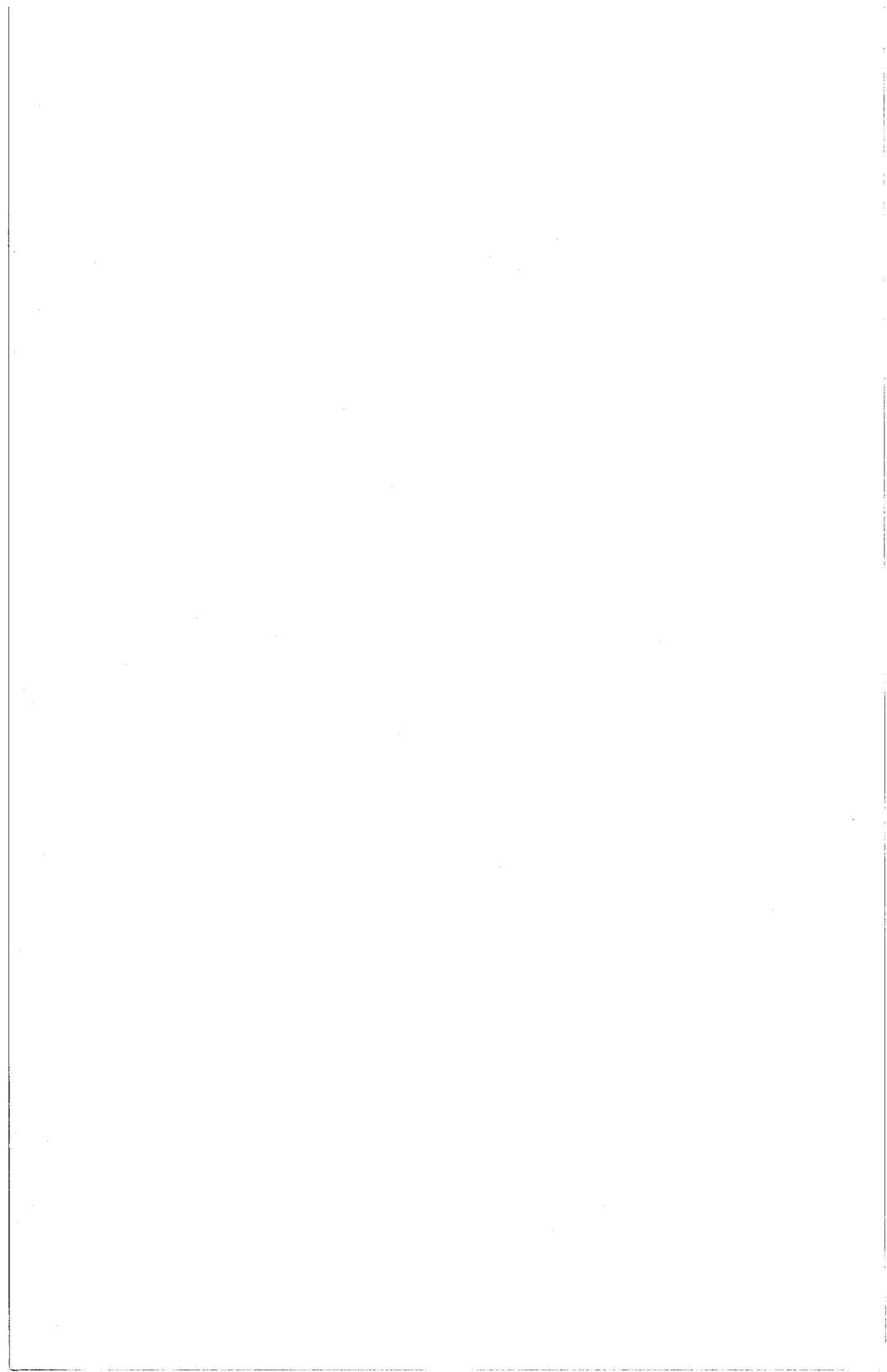

ELECTROMAGNETIC SCATTERING FROM CONDUCTING OBJECTS
IMMERSED IN A DISSIPATIVE HALF-SPACE

Rajeev Bansal

Department of Electrical Engineering and Computer Science
The University of Connecticut, Storrs, CT 06268
and

R. W. P. King

Gordon McKay Laboratory
Harvard University, Cambridge, MA 02138

The experimental setup and techniques for measuring the electromagnetic scattering from conducting objects submerged in salt-water are described. The incident field was produced by a half-wave ($\lambda = 1\text{m}$) dipole antenna lying near the surface of the water. The scattering object (a metal disk with or without a cut-out wedge) was located at a suitable depth approximately 1 meter away from the transmitting antenna. Measurements were made of the amplitude and the relative phase of the electric and the magnetic fields in a wide area over the object. The variation of the electromagnetic fields with respect to the depth of the scattering object was studied. Correlations were also sought between the measured field components and the size and the shape of the scattering objects.

URSI/B-9-2

ON THE SCATTERING OF LATERAL WAVES BY BURIED OR SUBMERGED OBJECTS

Ronald W. P. King

Gordon McKay Laboratory, Harvard University, Cambridge, MA 02138

An electromagnetic method for locating buried objects or regions of discontinuity makes use of a fixed horizontal insulated transmitting dipole with open or grounded ends and a movable probe, both located in the air (Region 2, $z \leq 0$) on the surface $z = 0$ of the earth (Region 1, $z \geq 0$). From measured observations on the total electric or magnetic field and its departure from the known incident field over an extensive area, the scattered field and the location of the scattering region are to be determined.

The first step in the analysis is the determination of the field incident on a buried or submerged object or a surface of discontinuity in the constitutive parameters. The horizontal wire antenna has been investigated as an eccentrically insulated antenna that has the properties of a transmission line with a complex wave number and characteristic impedance. The electromagnetic field generated by the currents in the antenna is that of a horizontal wire at $z \doteq 0$. By first determining the distribution of current and the effective length of the antenna, the entire field along the surface of the earth is readily obtained with the help of newly derived comprehensive formulas. The three components of primary interest are those tangent to the boundary surface, viz., $E_{1\rho}$, $E_{1\phi}$ and $B_{1\phi}$. These have been evaluated for a horizontal wire both with and without end terminations. At distances from the antenna greater than a half-wavelength in the earth, only the lateral-wave field is significant. Typical lateral-wave components of the field incident on an obstacle are:

$$E_{1\rho}^L(\rho, \phi, z) = \frac{\omega}{k_1} B_{1\phi}(\rho, \phi, z) = \frac{-\omega\mu_0 k_2}{2\pi k_1^2} \cos \phi e^{ik_1 z} e^{ik_2 \rho} g(k_2 \rho, k_1)$$

$$g(k_2 \rho, k_1) = \frac{ik_2}{\rho} - \frac{1}{\rho^2} - \frac{i}{k_2 \rho^3} - \frac{k_2^3}{k_1} \left(\frac{\pi}{k_2 \rho} \right)^{1/2} e^{-ik_2^3 \rho / 2k_1^2} \mathcal{F}$$

$$\mathcal{F} = \frac{1}{2} (1+i) - C_2(k_2^3 \rho / 2k_1^2) - iS_2(k_2^3 \rho / 2k_1^2)$$

and $C_2 + iS_2$ is the Fresnel integral. With the incident field known, the scattered field can be determined.

SCATTERING OF A LATERAL ELECTROMAGNETIC WAVE BY A METAL CYLINDER

M. Franklin Brown

Gordon McKay Laboratory, Harvard University, Cambridge, MA 02138

The cylindrical components of the field associated with lateral electromagnetic waves are introduced as the subject of former studies which have utilized a model of the earth's lithosphere at its planar interface with salt water. The lateral-wave field is incident upon and scattered by a thin metal cylinder. The usefulness of a recently derived formula for the z-component of the electric field associated with the denser of two adjacent material layers which adjoin in a planar abutment is outlined. The E_z component of former derivations and measurements allows a simple and accurate treatment of thin conducting cylinders as scattering objects. The generalization of the theory to fatter cylinders is also discussed. The measurements of both incident and scattered fields for thin and fat cylinders near the interface between two regions of a model lithosphere, one or both of which may be described by complex wave numbers, are presented.

URSI/B-9-4

CURRENT INDUCED ON A STRIP WHICH EXTENDS THROUGH THE PLANAR INTERFACE BETWEEN TWO SEMI-INFINITE HALF SPACES

Xu Xiao-Bang and Chalmers M. Butler
Department of Electrical Engineering
University of Houston
Houston, Texas 77004

The current induced by an incident plane wave on a conducting strip which extends through the planar interface between half spaces is determined. The strip is of uniform width and of infinite length and its axis is parallel to the media interface. The semi-infinite half spaces contain different materials and are homogeneous. The excitation is (i) transverse magnetic and (ii) transverse electric to the strip axis and is invariant in this axial direction. Integral equations for the structure are presented and discussed. Numerical methods for solving the equations are described and special analytical features of the solution procedures are investigated in some detail. The induced current is presented graphically as a function of the various parameters of the problem. From the data presented, one can see that known conditions at media interfaces are exhibited by the current and its derivative.

ON THE DYADIC GREEN'S FUNCTION FOR
A GROUNDED DIELECTRIC SLAB

Krzysztof A. Michalski
Department of Electrical Engineering
University of Mississippi
University, MS 38677

The electric field integral equation (EFIE) for the current on a conducting scatterer embedded in a layered medium is usually formulated in terms of only the electric vector potential \underline{A} , which is in turn related to the (unknown) current via the dyadic Green's function. This form of the EFIE, however, does not lend itself to the efficient solution techniques recently developed for objects residing in a homogeneous space by Glisson and Wilton (*IEEE Trans. Antennas Propagat.*, AP-28, 593-603, 1980) and Rao et al. (*ibid.*, AP-30, 409-418, 1981). Their procedure requires that the scattered electric field \underline{E} be expressed as $\underline{E} = -j\omega\underline{A} - \nabla\phi$, where ϕ is the scalar potential related to the charge density by way of the scalar Green's function. The purpose of this paper is to demonstrate that the EFIE for a scatterer embedded in a layered medium, such as a grounded slab, can be expressed in the desirable form by properly modifying the dyadic Green's function.

GUIDED-MODE LAUNCHING IN A SLAB WAVEGUIDE BY WAY OF DIFFRACTION AT THE EDGE OF A CONDUCTING SCREEN RESIDING ON ONE SURFACE OF THE SLAB

L. Wilson Pearson and Timothy H. Farris
Department of Electrical Engineering
University of Mississippi
University, MS 38677

The geometry pictured below is a canonical structure that is important to the modeling of lapped junctions between sheets of metallic and dielectric material. Such junctions arise, for example, when one joins such materials to form the skin of an airframe. To understand the scattering from and the penetration of energy into the interior of such a structure can be important in many application contexts. This presentation focuses on one physical phenomenon that comes to play in modeling both scattering and penetration--namely, the launching of slab-guided modes by an incident planewave by way of edge diffraction. In the scattering context, these modes have the potential to carry energy into the shadow region "behind" a scatterer much in the same way that creeping waves on a curved conducting surface do. They also can convey energy into the interior of a scatterer whose skin comprises some metal and some dielectric sheet material.

The fundamental diffraction problem has been analyzed by Coblin (Ph. D. thesis, University of Mississippi, 1983) by way of the Wiener-Hopf method and reported by Coblin and Pearson (National Radio Science Meeting, Houston, TX, May, 1983). This previously reported work deals with scattered field evaluation through asymptotic methods only for observation points exterior to the slab.

The work reported here deals with the uniform asymptotic evaluation of the fields for observation points interior to the slab. A number of alternative representations for this interior field is available (Tamir and Felsen, IEEE Trans. Ant. and Propag., v. AP-13, 1965, pp. 410-422). The present work focuses on the representation that treats all lateral wave terms through a single collective lateral wave term, which arises in the analysis as the leading term in the saddle-point contribution to the field. This particular form appears attractive for incorporating into GTD schemes since the collective term consolidates a number of wave entities into a single term that can be tracked as a single entity.



ANALYSIS OF AN ARRAY OF NARROW CONDUCTING
STRIPS ON A TWO-MEDIA INTERFACE

Chalmers M. Butler and Anthony Q. Martin
Department of Electrical Engineering
University of Houston
Houston, Texas 77004

The problem of determining the current induced on an array of narrow conducting strips which reside on a two-media interface is investigated by a method which is essentially analytical. The strips are narrow relative to the wavelength in either medium, they are parallel, their axes are parallel to the interface, and they may be of different widths. The excitation is taken to be transverse magnetic to and invariant along the strip axes. Coupled integral equations for the surface currents on the strips are derived and are shown to possess closed-form kernels (Butler, C.M., "Current induced on a conducting strip which resides on the planar interface between two semi-infinite half spaces," IEEE Trans. Ant. Prop., Vol. AP-32, March, 1984) even though the current-bearing strips are on a media interface. These equations are subjected to the narrow-strip condition which facilitates considerable reduction in their complexity. The strip currents are represented as power series augmented with the correct edge condition and are determined by the method proffered in the paper. Due to the pseudo-analytical nature of the solution method, it can handle large arrays - thirty to forty strips - which would be beyond the capacity of a typical moment method procedure. Current on strips is presented for several arrays of interest. For arrays of manageable size, strip currents determined by the present procedure are compared to those determined by the more usual moment method.

URSI/B-9-8

LOW FREQUENCY WAVE IMPEDANCE FOR A SINGLE WIRE ABOVE A HOMOGENEOUS EARTH

Robert G. Olsen and Daniel Rouseff
Department of Electrical and Computer Engineering
Washington State University
Pullman WA 99164-2210

A problem of growing importance is electromagnetic interference (EMI) caused by corona on electric power transmission and distribution lines. It is well known that electric and magnetic noise fields influence systems adjacent to the power line in different ways. Thus, for EMI surveys it is important to know both the electric and magnetic fields.

In some cases there is a very simple relationship between ratios of selected electric and magnetic field components (wave impedance). In these cases only the electric or the magnetic field must be measured. It is the purpose of this paper to outline the conditions for which simple relationships exist and to list the appropriate formulas.

One simple result for the low frequency wave impedance of a single wire measured at the earth's surface is

$$E_y/H_x = 2\eta_0 \frac{1 + 2d/\alpha + r^2/\alpha^2}{1 + 2d/\alpha + r^2/d\alpha + 2r^2/\alpha^2}$$

where

η_0 is the impedance of free space (120 π ohms)

d is the height of the wire above the earth

r is the distance from the wire to the field point

$\alpha = \sqrt{2} \delta \exp(-j\pi/4)$

$\delta = (2/\sigma_g \mu_0 \omega)^{1/2}$

is the skin depth of the earth

σ_g is the earth's conductivity

μ_0 is the permeability of free space

Here, E_y is the vertical electric field and H_x is the horizontal (perpendicular to the wire) magnetic field. One interesting result is that as the frequency (ω) tends to zero the impedance approaches $2\eta_0 \approx 754$ ohms.

BEHAVIOR OF RESONANT WIRES AND OF TRANSMISSION
LINES VERY NEAR THE EARTH

Peter Hayes
MITRE Corporation
Bedford, Massachusetts

Leon Peters, Jr.
Department of Electrical Engineering
Ohio State University
Columbus, Ohio 43212

It has been suggested that soil electrical parameters may be measured using the input impedance of a horizontal dipole antenna near the earth (e.g., Abul-Kassem et. al., 1973 URSI meeting, Boulder). A similar technique is to use the fundamental complex resonance of a wire near the earth. A moment method for determining the resonances as a function of wire length, radius, and height and of soil parameters was developed using the horizontal source Sommerfeld integral extended to complex frequencies. It was necessary to choose an integration contour in the complex plane such that branch cuts are not crossed. Measurements of a wire over water supported the theory.

One primary concern was the practical limitation in accuracy of the technique due to strong variations of the wire response with height changes. A margin of uncertainty in the height parameter is created by surface unevenness and a grass root layer. This results in a significant margin of uncertainty in soil parameter estimation.

A second basic concern was the effective measurement depth of such a technique. It was found computationally that the lower layer of a two-layer soil has very small effect on the resonances of a wire just below the air-earth interface when the top layer thickness is more than one-tenth the wire length. This effect is not caused by skin depth loss. Thus this type of measurement is little more than a surface measurement.

An extensive analysis of the natural propagation constant of round-wire and strip transmission lines lying on or near the earth yielded similar behavior regarding height sensitivity and probing depth. To account for non-uniform current distribution in the transverse dimensions, a moment method using subsectional basis functions and the required dyadic Green's function was used, together with Newton iteration for the propagation constant.

**URSI COMMISSION F SESSION F-1
REMOTE SENSING OF EARTH
ENVIRONMENTS**



Tuesday, June 26 8:30 A.M. - 12:00 NOON

Room: ST. GEORGE A

Chairman: Robert McIntosh

University of Massachusetts, Amherst, MA

**1. APPLICATION OF THE RADIATIVE
TRANSFER THEORY TO THE MULTI-
PLE SCATTERING BY LOW-AND-HIGH-
LOSS NONSPHERICAL PARTICLES,**

A. Ishimaru, Department of Electrical Engineering, University of Washington, Seattle, WA, D. Lesselier, Groupe D'Electromagnetisme, Laboratoire des Signaux et Systemes, Yvette, France, C. Yeh, Department of Electrical Engineering, University of California, Los Angeles, CA

**2. A THEORY OF MILLIMETER WAVE
PROPAGATION IN VEGETATION,**

G. M. Whitman, Electrical Engineering Department, New Jersey Institute of Technology, Newark, NJ, F. K. Schwering, U.S. Army Communications-Electronics Command, Fort Monmouth, NJ, Li-Wen Chen, Koasung College, Taiwan

**3. ACTIVE AND PASSIVE MICROWAVE
REMOTE SENSING OF LAYERED
ANISOTROPIC RANDOM MEDIUM,**

J. K. Lee and J. A. Kong, Department of Electrical Engineering and Computer Science and Research, Laboratory of Electronics, Massachusetts Institute of Technology, Cambridge, MA

**4. PASSIVE REMOTE SENSING OF
NONSPHERICAL PARTICLES,**

Leung Tsang and Boheng Wen, Department of Electrical Engineering, University of Washington, Seattle, WA

**5. DETERMINATION OF SNOWPACK
PROPERTIES FROM SATELLITE PAS-
SIVE MICROWAVE MEASUREMENTS,**

S. K. Burke, M. I. T. Lincoln Laboratory, Lexington, MA, Clinton J. Bowley, MITRE Corporation, Bedford, MA, James C. Barnes, Consultant, Acton, MA

**6. THE MEASUREMENT OF HORIZON-
TAL WIND VELOCITY NEAR THE
TROPopause USING RADAR TECH-
NIQUES,**

Francois Sicard and Robert K. Crane, Thayer School of Engineering, Dartmouth College, Hanover, N.H.

**7. THUNDERSTORM TURBULENCE DE-
TECTION AND TRACKING,**

George B. Chapman and Robert K. Crane, Thayer School of Engineering, Dartmouth College, Hanover, N.H.

**8. THE ELECTRICAL PROPERTIES OF
SEAWATER INCLUDING THE EFFECTS
OF CONDUCTIVITY RELAXATION,**

Michael E. Thomas, Applied Physics Laboratory, The Johns Hopkins University, Laurel, MD

**9. ON THE DETECTION OF ACOUS-
TIC-GRAVITY WAVES GENERATED BY
TYPHOON BY USE OF REAL TIME H. F.
DOPPLER FREQUENCY SHIFT SOUND-
ING SYSTEM,**

Yinn-Nien Huang, Kang Cheng and Sen-Wen Chen, Telecommunication Laboratories, Taiwan, Republic of China

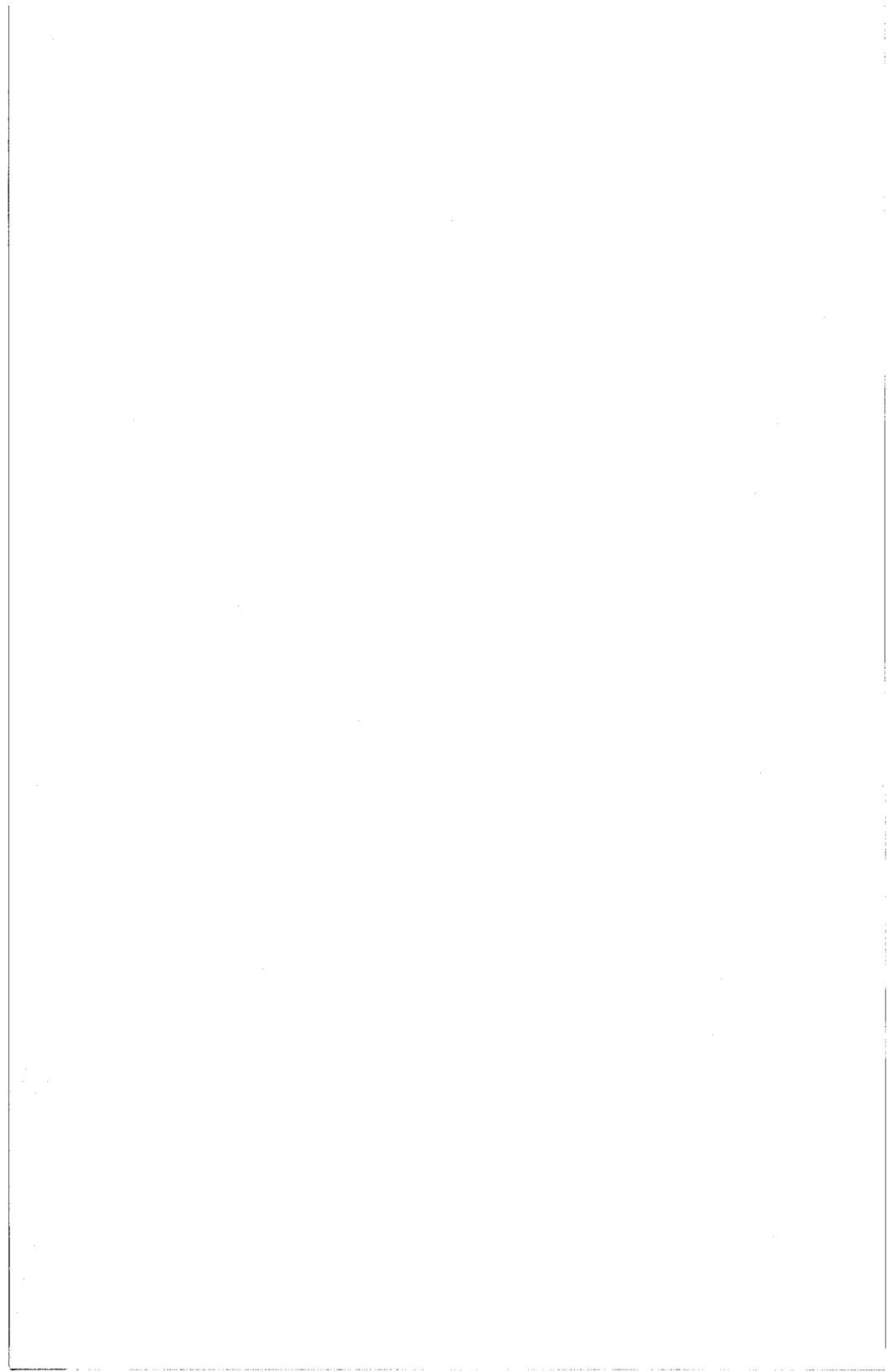

Application of the Radiative Transfer Theory
to the Multiple Scattering by Low-and-High-Loss
Nonspherical Particles

A. Ishimaru

Department of Electrical Engineering, Univ. of Washington
Seattle, WA 98195

D. Lesselier

Groupe d' Electromagnetisme, Laboratoire des Signaux et Systèmes
91190. Gif. sur. Yvette, France

C. Yeh

Department of Electrical Engineering, Univ. of California, Los Angeles
Los Angeles, CA 90024

Many studies have been devoted to the influence of aerosols or hydrometeors upon electromagnetic propagation in the atmosphere (T. Oguchi, IEEE Proc., 71(9), pp. 1029-1078, 1983). This influence can be assessed using the vector radiative transfer theory. This theory is applied herein to determine the incoherent field which results from the multiple scattering of a linearly polarized coherent plane wave (wavelength $\lambda = 1$ cm) by a distribution of nonspherical particles (maximal size $a = 1$ mm). Low-loss (ice) particles or high-loss (smoke) particles are considered, and their differences of behavior are especially emphasized.

The particles are assumed to be uniformly distributed (volume density ρ_v) between the horizontal planes $z = 0$, upon which the incoming wave is obliquely incident, and $z = d$. These particles are spheroids (oblate: disks, prolate: needles) that are rotationally symmetric about a vertical direction. This peculiar geometry involves the Fourier components of the Stokes' vector of the incoherent field that are independent, and each Fourier component is solution of an equation of transfer, and can be obtained using Gauss' quadrature formulas and eigenvalues-eigenvectors techniques from the previously computed discrete values of the particles' single scattering amplitudes. The co- and cross-polarized intensities of the incoherent field observed on both sides of the slab in a direction (θ, ϕ) follow.

Variations of these intensities vs. $\rho_v d$, θ , or ϕ are presented. It is in particular shown that these intensities increase vs. $\rho_v d$, before reaching a plateau (saturation). Within this plateau, at similar optical depths, much higher incoherent intensities are induced by low-loss particles than by high-loss ones. Moreover, cross-polarized intensities are of the same order of magnitude as the co-polarized intensities for low-loss particles, and much lower for high-loss ones. Otherwise, first-order approximation yields results which agree fairly well with those above, for angles of incidence up to a few tenth degrees.

URSI/F-1-2

A THEORY OF MILLIMETER WAVE PROPAGATION IN VEGETATION

G.M. Whitman
Electrical Engineering Department
New Jersey Institute of Technology
Newark, NJ 07102

F.K. Schwering
US Army Communications-Electronics Command
Fort Monmouth, NJ 07703

Li-Wen Chen
Koashung College, Taiwan

Millimeter-wave radios currently being developed for the US Army may have to operate in wooded areas for camouflage purposes. To ascertain the communication capability of placing these radios in such an environment, a study of millimeter wave propagation in vegetation (forest) using transport theory was undertaken. A plane-wave is assumed to enter a forest. The forest is modelled as a slab or half-space consisting of a random distribution of particles which scatter energy isotropically. For this case of planar geometry and plane-wave incidence, the familiar scalar equation of radiative transfer is relevant. Although this equation, subject to appropriate boundary conditions, has been extensively treated in the literature a new solution was found which is more analytic than those previously available. This resulted because of the use of Chebyshev polynomials as basis functions for series expansions of the diffuse or incoherent intensity. This choice of basis functions reduced two of the three linear systems of equations, which had to be solved, to systems of two equations each. Hence, numerical evaluation is very efficient. Data will be presented which shows the range and angular dependence of the diffuse intensity as well as the range dependency of the diffuse flux.

ACTIVE AND PASSIVE MICROWAVE REMOTE SENSING
OF LAYERED ANISOTROPIC RANDOM MEDIUM

J. K. Lee and J. A. Kong

Department of Electrical Engineering and Computer Science
and Research Laboratory of Electronics
Massachusetts Institute of Technology
Cambridge, Massachusetts 02139

In the active and passive microwave remote sensing of earth terrain, randomly fluctuating permittivities have been modelled to account for the volume scattering effects of layered terrain media with either the radiative transfer theory or the wave theory. But these models do not take into account the medium anisotropy which has been observed experimentally in sea ice, vegetation fields with row structures, and when leaves and stalks have preferred orientations in azimuthal directions.

To properly simulate this kind of terrain, we develop the model of an anisotropic random medium with an arbitrarily oriented optic axis. We make use of the dyadic Green's function for a two-layer anisotropic medium and apply Born approximation to obtain analytical expressions for the bistatic scattering coefficients and the radar backscattering cross sections. The emissivity is then calculated by using the energy conservation and reciprocity arguments.

The spectral and angular responses of the backscattering coefficients for active remote sensing and the brightness temperatures for passive microwave remote sensing are illustrated numerically along with their dependence on variance, the correlation lengths and the permittivities, all of which are assumed to be anisotropic. It is seen that the first order scattering effects can lead to depolarization due to anisotropy. The theoretical results are used to match experimental data obtained from active remote sensing of sea ice, and from field measurements with radiometers when the row structures of the vegetation canopy are important factors, and when the stalks of a corn field is cut and laid on the ground in aligned azimuthal directions.

URSI/F-1-4

PASSIVE REMOTE SENSING OF NONSPHERICAL PARTICLES

Leung Tsang and Boheng Wen
Department of Electrical Engineering
University of Washington
Seattle, Washington 98195

In recent years considerable attention has been paid to the problem of propagation in a medium embedded with discrete particles. Such problems have direct applications in remote sensing of the atmosphere and the earth where the particles can be rain, ice crystals, fog, snow, leaves, etc. and are generally nonspherical. Within the framework of radiative transfer theory, the study of coherent and incoherent propagation by randomly distributed nonspherical particles is carried out by using the Stokes' vector. The extinction matrix in radiative transfer theory was calculated by applying Foldy's approximation in coherent wave propagation theory, and for nonspherical particles, is generally nondiagonal showing strong coupling among all four Stokes' parameters.

In this paper, we study passive remote sensing of nonspherical particles. The fluctuation dissipation theorem is used to calculate the emission of a single nonspherical particle. The thermal emission of a conglomeration of particles is then introduced as a source term in the radiative transfer equation. Generally, all the four Stokes' parameters in the vector source term are nonzero and are proportional to the absorption coefficient in the backward direction. The constituents of the vector radiative transfer equations, extinction matrix, phase matrix, and emission vector are constructed in different manners and have been further complicated by the introduction of the third and fourth Stokes' parameters. Thus it is important to ascertain that when these constituents are combined to form the vector radiative transfer equations, energy conservation and reciprocity still hold. These two laws are shown to be true within the framework of radiative transfer theory by showing that the emissivity of vertical and horizontal polarized waves in passive sensing are related to the bistatic scattering coefficients of active sensing in the usual manner. In addition, the emissions of the third and fourth Stokes' parameters are also expressed in terms of bistatic scattering coefficients. The theory is illustrated with numerical examples of the four brightness temperatures as a function of medium parameters and observation angles.

Boston Meeting, June 1984
URSI Commission F: Remote Sensing

DETERMINATION OF SNOWPACK PROPERTIES FROM
SATELLITE PASSIVE MICROWAVE MEASUREMENTS*

Hsiao-hua K. Burke
M.I.T. Lincoln Laboratory, Lexington, MA 02173-0073

Clinton J. Bowley
MITRE Corporation, Bedford, MA 01730

James C. Barnes
Consultant, 6 Rose Court, Acton, MA 01720

The use of satellite microwave data to determine snowpack properties is investigated through calculation of theoretical microwave brightness temperatures with actual satellite microwave measurements. Archived data from the Nimbus-5 and Nimbus-6 Electrically Scanning Microwave Radiometers (ESMR), as well as data from the Nimbus-7 Scanning Multifrequency Microwave Radiometer (SMMR), are analyzed for a study area in the north-central United States.

The results of the investigation indicate that snow boundaries can usually be defined by the 37 GHz or 18 (19) GHz data because of the sharp decrease in brightness temperature when going from land to a snow surface. For dry snow conditions, the 37 GHz data display a decrease in brightness temperature with snow depth due to the stronger volume scattering effect of the deeper snow; at 18-19 GHz, the sensitivity to snow depth is not as significant. The onset of snowmelt can be determined at both microwave frequencies investigated (18-19 GHz and 37 GHz) because of the significant increase in the brightness temperature with melting due to the decrease in volume scattering that occurs in the presence of free water.

*The work was carried out when the authors were with Environmental Research and Technology, Inc., 696 Virginia Road, Concord, MA 01742.

URSI/F-1-6

THE MEASUREMENT OF HORIZONTAL WIND VELOCITY NEAR THE TROPOPAUSE USING RADAR TECHNIQUES

Francois Sicard and Robert K. Crane
Thayer School of Engineering
Dartmouth College
Hanover, N.H. 03755

In many meteorological applications it is necessary to obtain a wind profile, that is, horizontal wind velocity measured as a function of height. The traditional radar-based wind velocity measurement technique has been the Doppler beam-swinging method, in which the components of the wind's velocity are determined from the Doppler-shifted spectra of reflected signals along three different lines of sight. This research investigates the drift technique, which attempts to exploit the correlation between reflected signals. The correlation analysis is conducted in the frequency domain using the concepts of coherency and phase. A simulation model of the backscattering of radar signals by atmospheric turbulence is used to generate coherency and phase spectra. In frequency bands where the coherency between reflected signals is significantly above zero, it is expected that the phase spectrum is approximately linear with a slope proportional to the wind speed. Least squares fitting is used to obtain this slope and hence an estimate of wind speed. The model is then studied to determine an optimal wind velocity measurement method.

THUNDERSTORM TURBULENCE DETECTION AND TRACKING

George B. Chapman and Robert W. Crane
Thayer School of Engineering
Dartmouth College
Hanover, N.H. 03755

An improved tracking procedure was developed to facilitate the early detection and prediction of thunderstorm turbulence. Volume Cells (localized peaks in a radar reflectivity field) were grouped into clusters based on their relative proximity. Preliminary work (Crane 1981) suggested a correlation between cell clusters and turbulence updraft/downdraft boundaries in convective storms. The Cluster's statistical spatial parameters were studied and used to help forecast the location and movement of high turbulence regions. Estimates of the Cluster's state variable parameters were made using correlation analysis pattern recognition over localized regions; optimal filtering (The discrete-time Kalman filter); and suboptimal filtering employing an autoregressive moving average (ARMA) process. The performance of each method was evaluated in terms of prediction success and computer resource considerations. A simulation model was developed and used to test the performance of the tracking procedures.

URSI/F-1-8

THE ELECTRICAL PROPERTIES OF SEAWATER AT MICROWAVE FREQUENCIES

Michael E. Thomas
Applied Physics Laboratory
The Johns Hopkins University
Johns Hopkins Road
Laurel, MD 20707

The electrical properties of seawater at microwave frequencies have been typically modelled by a formula for the complex permittivity

$$\epsilon = \epsilon_{\infty} + \frac{\epsilon_s - \epsilon_{\infty}}{1 + (j\omega\tau)^{1-\alpha}} - j \frac{\sigma}{\omega\epsilon_0}$$

where ϵ_{∞} is the dielectric constant beyond the Debye relaxation process, ϵ_0 is the permittivity of free space, ϵ_s is the static dielectric constant, τ is the relaxation time, σ is the conductivity and α is an empirical spreading parameter of relaxation times. In principle, ϵ_{∞} and σ are functions of temperature, salinity and frequency, and ϵ_s and τ are functions of temperature and salinity. In practice, ϵ_{∞} is a constant and σ is a constant in frequency. Also, for water, $\alpha=0$ is generally used. The dielectric behavior is modelled by Debye relaxation which accounts for the damped rotation of the molecule in the liquid. Experimental data is then fitted to the complex permittivity formula. The result is a reasonable representation of the true dielectric and conductive values of seawater below X-band.

Precision microwave radiometry requires equal precision of the known electrical properties of seawater. To improve the current semi-empirical formulas requires a greater understanding of the theory including observed anomalous electrical properties. Effects of the far-infrared resonance absorption bands, conductivity relaxation and anomalous dielectric and conductive properties will be discussed. Potentially, by considering these effects, the complex permittivity will be valid at and above X-band and more accurate over all.

ON THE DETECTION OF ACOUSTIC-GRAVITY WAVES
 GENERATED BY TYPHOON BY USE OF REAL TIME
 H.F. DOPPLER FREQUENCY SHIFT SOUNDING SYSTEM

Yinn-Nien Huang, Kang Cheng and Sen-Wen Chen
 Telecommunication Laboratories, M. O. C.
 Chung-Li P.O. Box 71, Taiwan, ROC

A real time high frequency Doppler frequency shift sounding system was set up in Taiwan Island in 1982. The system consists of three high frequency transmitting stations each continuously transmits two precise frequencies of 5.2 and 7.8 MHz and two Doppler frequency shift recorders located at Lunping Observatory (25.00° N; 121.17° E). Each Doppler frequency shift recorder records simultaneously the three Doppler frequency shifts of one frequency transmitted from three transmitting stations. The system was designed and constructed such that the time variations of the six Doppler frequency shifts can be directly viewed from the recording chart paper.

The following figure shows an example of ionospheric variations caused by the acoustic-gravity wave generated by typhoon Wayne on July 24, 1983 by this Doppler frequency shift sounding system. Several similar variations have been found in the last two years. In this report, all typhoons generated in 1982 and 1983 have been used to study the detectability of typhoon generated acoustic-gravity waves by use of the H.F. Doppler frequency shift sounder.

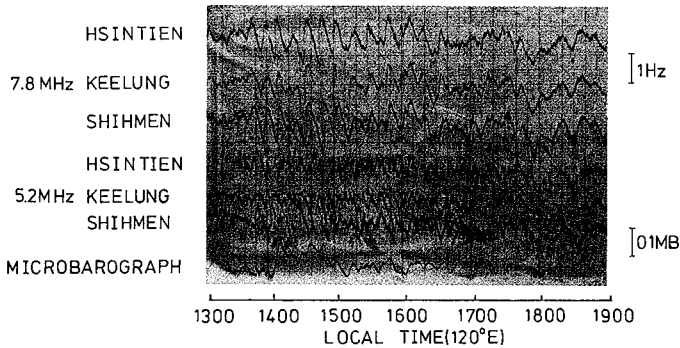

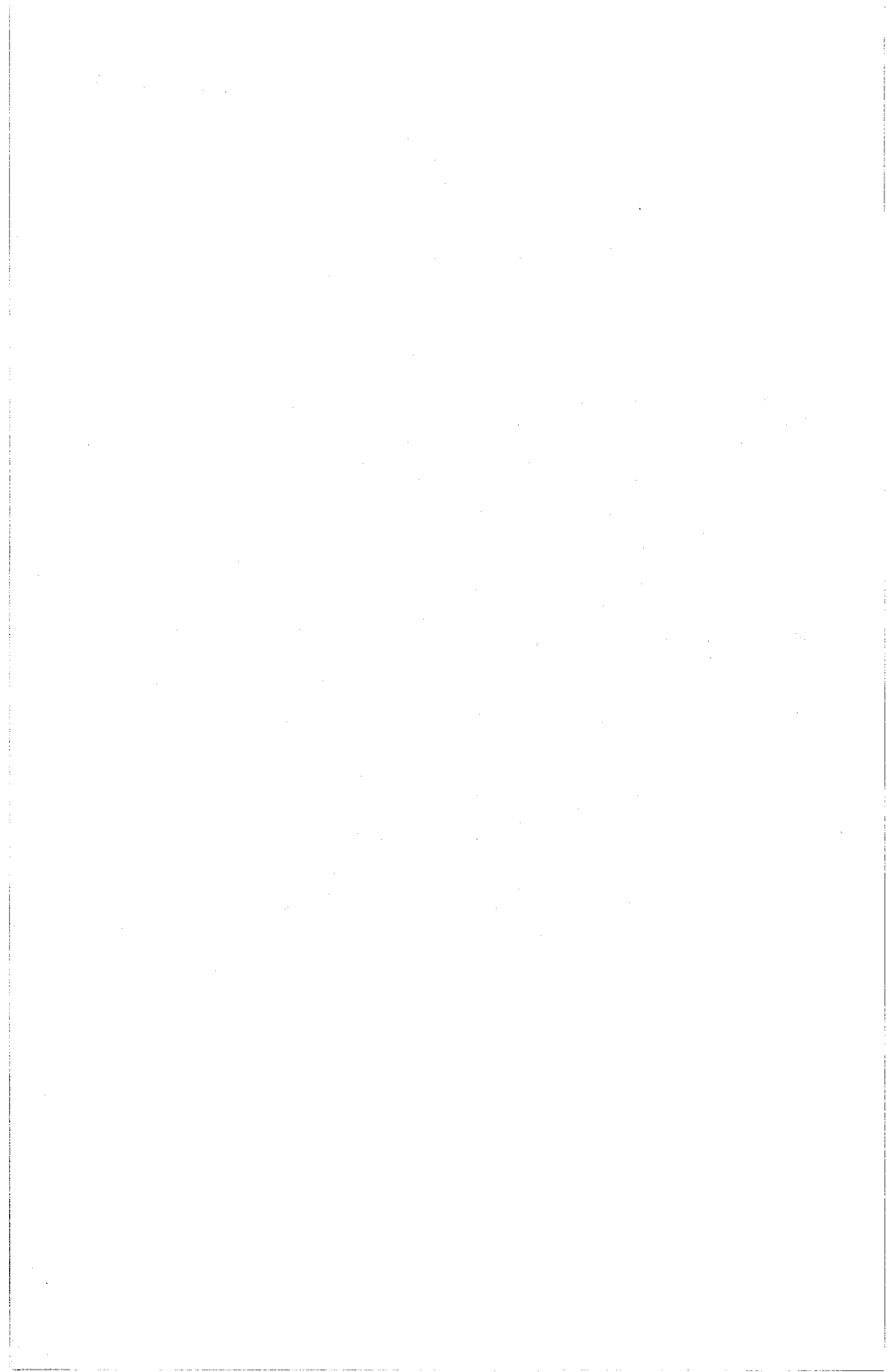

**URSI COMMISSION B SESSION B-10
SCATTERING**



Tuesday, June 26 1:30 - 5:00 P.M.

Room: ESSEX NORTH CENTER

Chairman: Ronald J. Pogorzelski

**TRW Space and Technology Group,
Redondo Beach, CA**

1. BROADSIDE RADAR CROSS SECTION OF THE PERFECTLY CONDUCTING CUBE, Arthur D. Yaghjian and Robert V. McGahan, Electromagnetic Sciences Division, Rome Air Development Center, Hanscom AFB, MA

2. A RADAR BACKSCATTERING STUDY OF SHADOWING EFFECTS AND MUTUAL INTERFERENCE, C. Long Yu, Electromagnetic Systems Division, Pacific Missile Test Center, Point Mugu, CA

3. BACKSCATTERED PATTERNS FROM OBSTACLES PLACED ON A SMOOTH CONDUCTING SURFACE, J. Volakis, W. D. Burnside, L. Peters, The Ohio State University ElectroScience Laboratory, Columbus, OH

4. SCATTERING FROM A CONDUCTING PLATE ATTACHED TO A BODY OF REVOLUTION, Juang Lu Lin, Seattle, WA

5. SCATTERING FROM METALLIC BODIES COATED WITH ANISOTROPIC MATERIALS, R. D. Graglia and P. L. E. Uslenghi, Department of Electrical Engineering and Computer Science, University

of Illinois, Chicago, IL

6. ELECTROMAGNETIC SCATTERING FROM A PLASMA COLUMN CONTAINING AN AZIMUTHAL BIASING FIELD, Larry K. Warne, Sandia National Laboratories, Electromagnetic Analysis Division, Albuquerque, NM

7. SCATTERING FROM THIN DIELECTRIC DISKS, D. M. Le Vine, Goddard Laboratory for Atmospheric Science, Goddard Space Flight Center, Greenbelt, MD, A. Schneider, CyberCom Corporation, Arlington, VA, R. H. Lang, Department of Electrical Engineering & Computer Science, George Washington University, Washington, D.C.

8. SCATTERING FROM FREQUENCY SELECTIVE SURFACES IN PRESENCE OF EXTENDED SOURCES, R. Orta, R. Tascone, and R. Zich, Dipartimento di Elettronica, Politecnico di Torino, Torino, Italy

9. SCATTERING FROM LARGE SMOOTH-CORNERED CONDUCTING CYLINDERS, M. Sultan and R. Mittra, University of Illinois, Urbana, IL

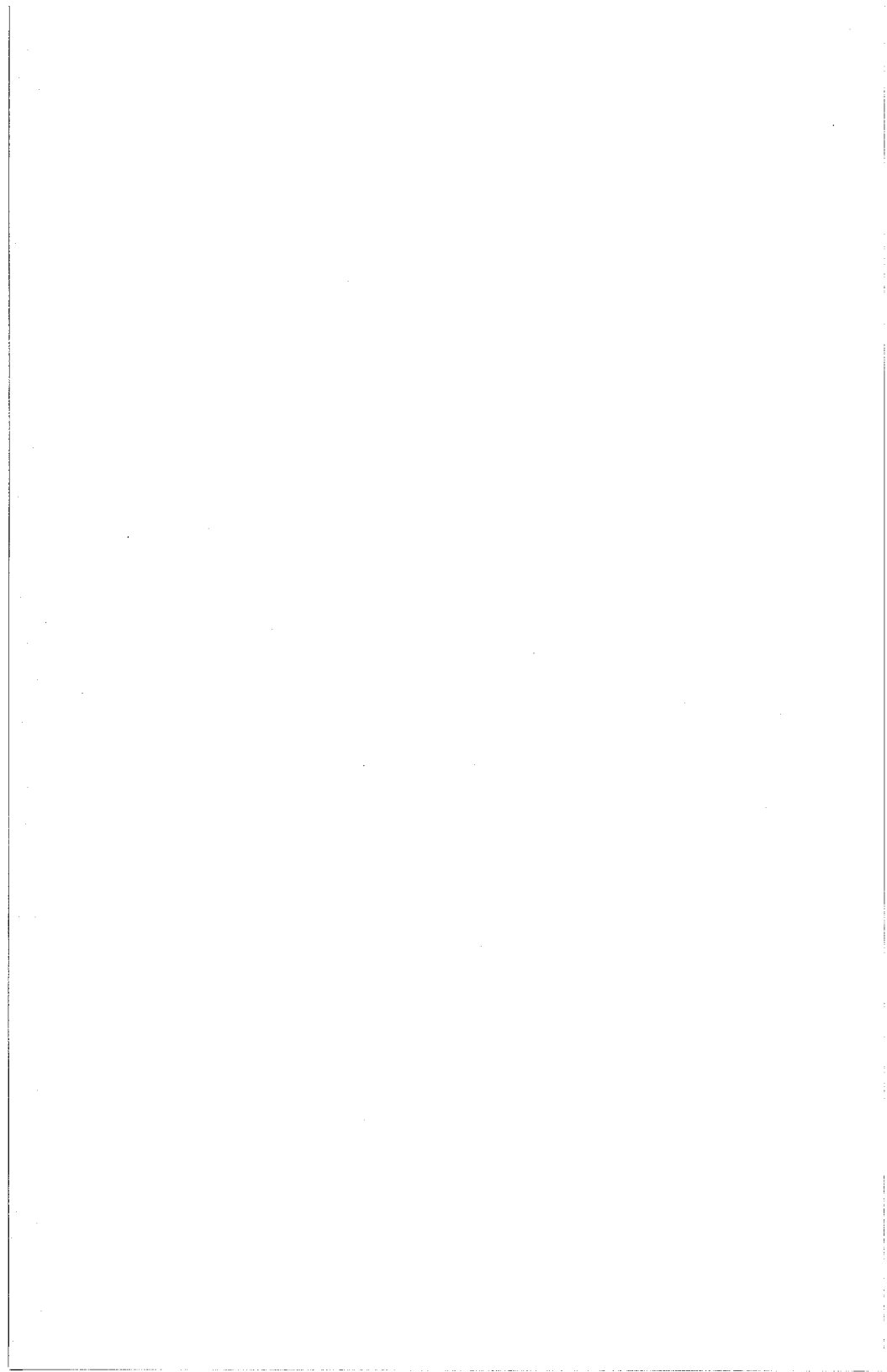

BROADSIDE RADAR CROSS SECTION OF THE PERFECTLY
CONDUCTING CUBE

Arthur D. Yaghjian
Robert V. McGahan
Electromagnetic Sciences Division
Rome Air Development Center
Hanscom AFB, MA 01731

The broadside radar cross section (RCS) of the perfectly conducting cube is predicted from arbitrarily low to arbitrarily high frequencies, and compared to measured data taken for cube side lengths ranging from .15 to 4 wavelengths. The predicted and measured RCS curves agree to within the estimated experimental limits of accuracy of ± 1 dB. At low frequencies the magnetic-field integral equation was "augmented" to eliminate its spurious homogeneous solutions and thus to produce high accuracy beyond the resonance region up through the intermediate frequency range. At high frequencies the conventional diffraction solution was "enhanced" to produce high accuracy down through the intermediate frequency range into the resonance region. Close agreement between these two very different theoretical solutions in the intermediate frequency range confirmed the validity of each solution and permitted calculation of a reliable composite RCS curve for all frequencies.

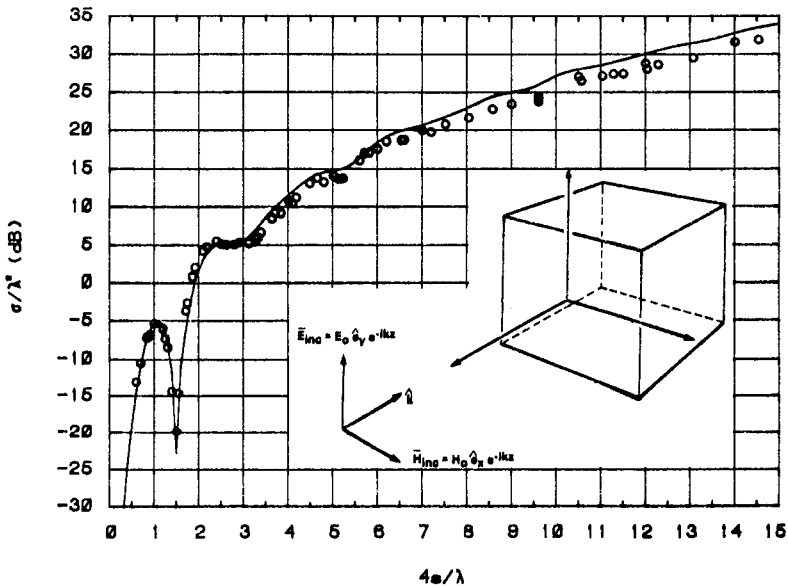

URSI/B-10-2

A RADAR BACKSCATTERING STUDY OF SHADOWING EFFECTS AND MUTUAL INTERFERENCE

C. Long Yu
Electromagnetic Systems Division
Pacific Missile Test Center
Point Mugu, California 93042

The plane wave backscattering from a finite conducting plate in the presence of a conducting cylinder or another finite conducting plate is the main interest of this paper. The purpose of this work is to investigate the electromagnetic mutual-interference and shadowing effects between various geometrical shapes. These problems represent higher-order electromagnetic backscattering contributions to the radar cross section (RCS) of a modern radar target. Both continuous-wave and high-resolution RCS measurements were conducted to study the scattering phenomenon as well as the scattering mechanism involved. The experimental results will be presented for several cases of interest.

BACKSCATTERED PATTERNS FROM
OBSTACLES PLACED ON A SMOOTH CONDUCTING SURFACEJ. Volakis
W.D. Burnside
L. PetersThe Ohio State University ElectroScience Laboratory
1320 Kinnear Road
Columbus, Ohio 43212

The Uniform Theory of Diffraction is used to obtain a solution for the scattered field of smooth structure (an ogive) with various appendages placed on it. Multiple interactions between the surface and the appendage are included in the solution. An iterative procedure is used to find the incident rays that produce backscattered rays. The Equivalent Current Concept is used to evaluate the fields when there is a confluence of backscattered rays (caustic). Experimental results are in excellent agreement with the computations.

The appendages include a segment of a cylinder whose axis is parallel to and displaced from the axis of the ogive and flat plate structures placed in a plane containing the ogive axis. The front end of the cylinder is terminated both in a knife edge and also a rounded edge.

Results are to be shown that break down the computed patterns into particular mechanisms to illustrate specific contributions to the total backscattered patterns. In certain regions of the pattern, the multiple interactions become dominant contributors.

URSI/B-10-4

SCATTERING FROM A CONDUCTING PLATE ATTACHED TO A BODY OF REVOLUTION

Juang Lu Lin
PO Box 3999, M/S: 8W-04
Seattle, WA 98124

An approximate solution is developed to calculate the electromagnetic scattering from a conducting plate attached to an arbitrary metallic body of revolution (BOR) for arbitrary incidence and polarization. The conducting plate is, in general, attached to the shadow region of BOR in such a way that the composite body no longer belongs to the class of BOR.

Based on the physical optics solution, the effect due to the entire shadow region would have been completely ignored. In order to improve the accuracy of the solution, the method of approach is outlined as follows:

- (1) Determine the surface current density and scattered far fields of BOR without the plate, using the conventional solution available to BOR.
- (2) Obtain the surface current density of the conducting plate, using the conventional methods of moment with excitation fields including the incident wave and the near field maintained by BOR.
- (3) Find the scattered far field of the plate, based on the induced current determined in (2).
- (4) The scattered far field by BOR plus that of the conducting plate is the resultant scattered far field of the composite body.

The approach described above does take advantage of using BOR solution. The interacting effect of the conducting plate to BOR is neglected in this investigation. However, this effect is considered to be secondary as the plate is situated in the shadow region of BOR and it would not alter considerably the surface current distribution on the illuminated region of BOR.

Finally, numerical examples will include the conducting plate attached to a sphere, and an arbitrary BOR.

SCATTERING FROM METALLIC BODIES COATED WITH ANISOTROPIC MATERIALS

R.D. Graglia and P.L.E. Uslenghi

Department of Electrical Engineering and Computer Science
University of Illinois, Chicago, IL 60680

Electromagnetic scattering from a perfectly conducting body coated partially or totally by a layer of anisotropic material is considered, in the frequency domain. The anisotropic material is characterized by a (complex) electric susceptibility tensor $\bar{\chi}_{ec}$, which includes both anisotropic permittivity and anisotropic conductivity, and by a magnetic susceptibility tensor $\bar{\chi}_m$. This problem finds important applications in certain types of radar absorbers and in substrates for millimeter-wave antennas and for integrated-optical devices.

The theoretical formulation given previously for scattering by anisotropic bodies in free space (R.D. Graglia and P.L.E. Uslenghi, National Radio Science Meeting, Houston, TX, May 1983; R.D. Graglia, Doctoral Thesis, University of Illinois at Chicago, November 1983; R.D. Graglia and P.L.E. Uslenghi, IEEE Trans. AP (Comm.), in press) is herein extended to anisotropic materials in contact with both free space and perfect conductors. The electric and magnetic fields inside the anisotropic material are solutions of two coupled vector integro-differential equations, which involve integrals over the volume of the anisotropic material and over the air-anisotropic material and metal-anisotropic material interfaces. In two-dimensional problems, volume and surface integrals are reduced to area and contour integrals over the cross-section of the scatterer.

A computer code is implemented in two dimensions. The area of integration is broken into triangles with unknown fields at the vertices; the line integrals are broken into segments with unknown fields at the end-points. Detailed numerical results are presented for the stripline and for the circular cylinder coated by a layer of constant thickness.

URSI/B-10-6

ELECTROMAGNETIC SCATTERING FROM A PLASMA COLUMN CONTAINING AN AZIMUTHAL BIASING FIELD

Larry K. Warne, Sandia National Laboratories
Electromagnetic Analysis Division, 7553

Abstract

The problem of a plane electromagnetic wave impinging normally on a column of plasma is considered when the column contains a radially distributed axial static current. The medium thus resembles, in some respects, a lightning discharge or certain fusion plasmas. The resulting azimuthal magnetostatic field is responsible for the gyroelectric nature of the column. The plasma is treated in the usual linear approximation and is further assumed to be cold and incompressible.

The problem is formulated as a pair of coupled ordinary differential equations in the axial electric and magnetic fields. For mathematical simplicity, the case of uniform biasing field (axial static current density inversely proportional to radius) and uniform charge density is considered in detail. The resulting modal equations are solved by the method of Frobenius when the column radius is of moderate size. An integral representation for the modal solution is also given which provides useful asymptotic approximations when the column radius is large.

The far zone scattered fields are in general elliptically polarized as a result of Faraday rotation within the column. This is in contradistinction to the axial magnetostatic field case (Wescott, B. S., Proc. Camb. Phil. Soc. 66 129-143 (1969)). The cross polarized component vanishes in the incident direction as a result of the symmetry of the column.

More general axial current density and charge density distributions are treated by use of invariant imbedding. The scattered fields in certain cases of nonuniform biasing field have many characteristics in common with the simpler uniform problem.

The fields near the origin of the column are considered in some detail since under certain conditions they exhibit field singularities analogous to those occurring in wedge domains.

SCATTERING FROM THIN DIELECTRIC DISKS

D. M. Le Vine
Goddard Laboratory for Atmospheric Science
Goddard Space Flight Center
Greenbelt, Maryland

A. Schneider
CyberCom Corporation
Arlington, Virginia

R. H. Lang
Department of Electrical Engineering & Computer Science
George Washington University
Washington, D. C.

A solution has been obtained for scattering from thin dielectric disks which applies in both the high and low frequency limits. The solution is obtained by expressing the scattered fields in terms of the currents induced inside the disk by the incident radiation and then approximating these currents with the currents which would exist inside a dielectric slab of the same thickness, orientation and dielectric properties (Le Vine et al., J. Opt. Soc. Amer., Vol. 73, pp. 1255-1266, 1983). One can show that this approximation reduces to the Rayleigh approximation when the disks thickness, T , is small compared to the wavelength of the incident radiation and that the approximation yields conventional physical optics solutions when the characteristic dimension, A , of the geometrical cross section of the disk (e.g. the diameter of a circular disk) is large compared to wavelength. When the ratio A/T is large enough it is possible for the disk to be in one or the other of these regimes for incident radiation of any frequency including frequencies when $kA \approx 1$.

As a check on this theory a comparison has been made with measurements of scattering from dielectric disks. Comparison has been made with the measurements of Allan and McCormick (IEEE Trans. AP-S, Vol. 28, pp. 166-169, 1980). Agreement between the measured and predicted scattering cross section was obtained for disks in the frequency range $0.8 < kA < 4.0$ with a cross section to thickness ratio, A/T , as low as $A/T = 10$.

URSI/B-10-8

SCATTERING FROM FREQUENCY SELECTIVE SURFACES IN PRESENCE OF EXTENDED SOURCES

R. Orta, R. Tascone and R. Zich
CESPA (CNR), Dipartimento di Elettronica
Politecnico di Torino
Corso Duca degli Abruzzi 24, TORINO (ITALY)

Frequency Selective Surfaces (F.S.S.) are becoming increasingly popular in antenna system design for space applications, since they allow the reduction of the number of main reflectors by creating multiple images of the focal region at different frequencies.

At present much effort has been devoted to the analysis of the scattering properties of such structures, in particular for what concerns the shape of the conducting patches, the presence of dielectric supports, the interaction of closely spaced grids. All these studies assume a plane wave excitation of the Frequency Selective Surface. However, recently developed antenna systems make use of F.S.S. placed at short distance from both the feed cluster and the reflectors, so that a plane wave characterization is no longer satisfactory.

In this paper we remove this limitation and present an analysis of the scattering behaviour of F.S.S. in presence of extended sources (feed clusters). Both the observation point and the sources are assumed to be placed at finite distance from the F.S.S., so that knowledge of the near field of the feed cluster is required.

Starting from the spectral characterization of the F.S.S., two approaches are considered.

The first one is based on the application of the reciprocity theorem where the integration surface surrounds the F.S.S.. The two systems of sources are respectively the actual source in absence of the F.S.S. and a test point source in presence of it. In this way we obtain directly the degradation introduced by the actual F.S.S. with respect to the ideal case.

The second approach is based on the definition of the relevant Green's function and on the subsequent computation of the total scattered field by means of the superposition principle.

Both methods lead to the evaluation of the global performances (secondary pattern) of the system composed by feed clusters, F.S.S. and solid reflector.

SCATTERING FROM LARGE SMOOTH-CORNERED CONDUCTING CYLINDERS

M. Sultan and R. Mittra
 University of Illinois
 Urbana, Illinois

The effect of smoothing of the sharp edges of a scatterer on its RCS characteristics is of considerable interest in the field of radar scattering. In this paper we consider the problem of scattering by an electrically large conducting cylinder of rectangular cross-section whose corners are progressively smoothed until it becomes a circular cylinder in the limit. Extensive numerical results are obtained for the induced currents on the cylinder, and the results are compared with those predicted by the Physical Optics approximation and the exact solution for the circular cylinder. When the scatterer is electrically large, the size of the moment method matrix can become rather large, and its solution time-consuming as well as unwieldy. For these situations, iterative procedures offer an alternative to matrix inversion, and allow the possibility of handling a large system of equations without the need for storing any matrices. In this paper, we have employed an iteration procedure based on the method of conjugate gradients to derive the solution of the scattering problem described above. The iteration procedure we use does not require the storage of the entire matrix; however, the elements of the matrix must be repeatedly generated at each iteration step. Consequently, it is highly desirable to find ways to reduce the computational time for each element. We accomplish this by using the simplest type of basis and testing functions and by employing a look-up table in conjunction with linear interpolation.

The cross-section of the cylinder is defined by the equation: $x^{2n} + y^{2n} = a^{2n}$. For $n = 1$, the cylinder is circular and tends to a square cylinder in the limit $n \rightarrow \infty$. The $k_0 a$ size for the cylinder was chosen to be 20 for all n , where k_0 is the free-space wave number. The contour of the cylinder was divided into 240 segments, which is equivalent to using about 9 segments per wavelength for the square cylinder and 12 per wavelength for the circular one. To avoid problems arising due to internal resonances, an additional 59 PEC segments were introduced at the interior of the cylinder and these segments were treated in exactly the same manner as the surface segments. It is interesting to note that the resonance problems are totally eradicated via the artifice of using fictitious internal segments. And yet, the final currents on the internal segments become vanishingly small upon convergence.

Our study shows that the smoothing of the corners has a significant effect on the behavior of the current distribution in the immediate vicinity of an edge, at least initially, when the edge is very sharp. As a final remark, we note that GTD can not be employed to solve the smooth edge problem when the radius of the curvature of the edge is small. The method presented in this paper provides a convenient alternative both to matrix inversion and to ray methods.

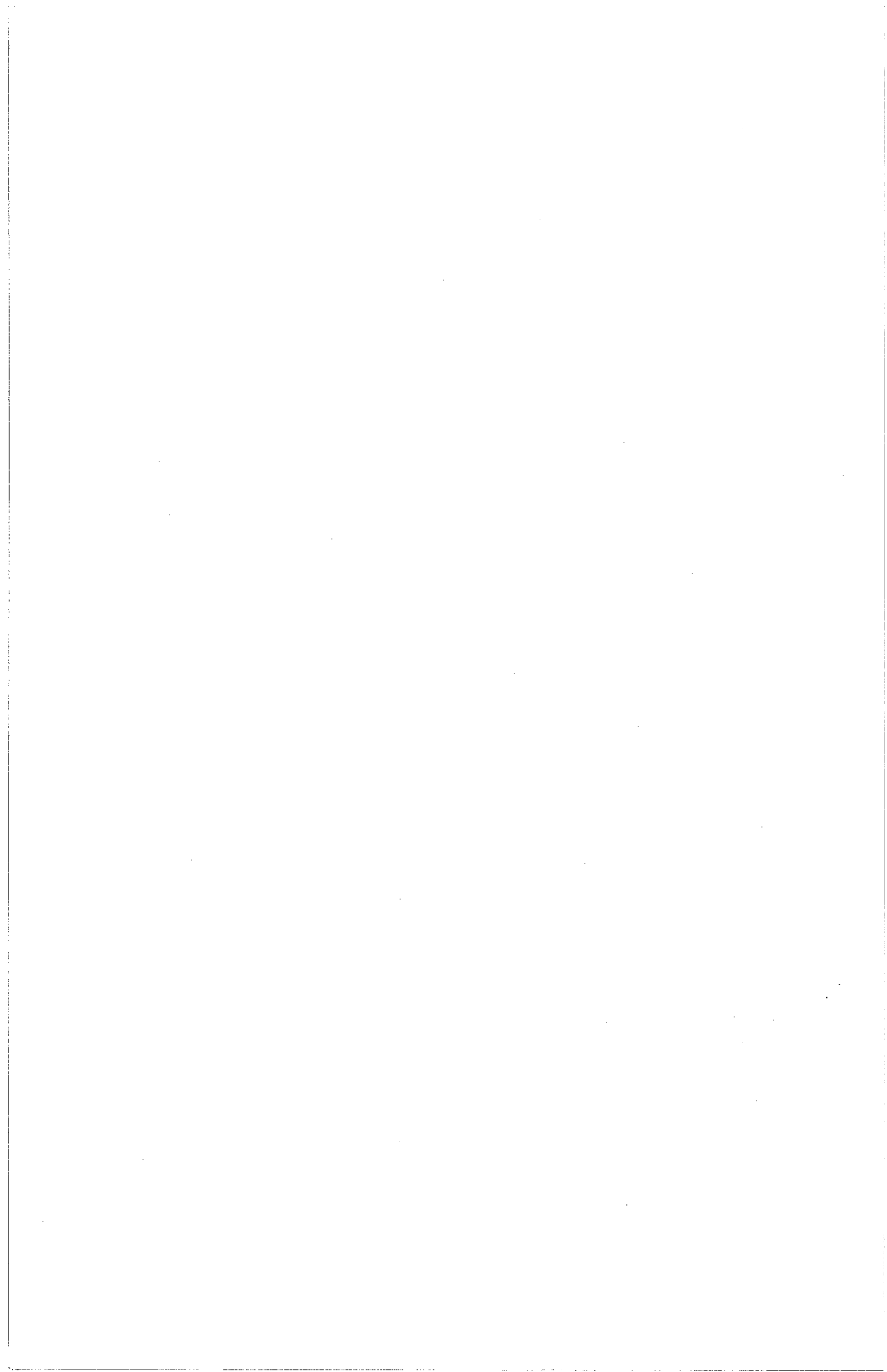

URSI COMMISSION B SESSION B-11
MICROSTRIP AND STRIPLINE
ANTENNAS AND STRUCTURES

Tuesday, June 26 1:30 - 5:00 P.M.

Room: ESSEX SOUTH

Chairman: Stuart A. Long

University of Houston, Houston, Texas

1. AN EFFICIENT MOMENT METHOD ANALYSIS OF INFINITE MICROSTRIP ARRAYS, S. M. Wright and Y. T. Lo, Department of Electrical Engineering, University of Illinois, Urbana, IL

2. ANALYSIS OF A LINEAR MICROSTRIP ARRAY COUPLED BY MICROSTRIP TRANSMISSION LINES, E. H. Newman and J. E. Tehan, The Ohio State University ElectroScience Laboratory, Department of Electrical Engineering, Columbus, OH

3. NUMERICAL SOLUTION OF RADIATION FROM MICROSTRIP STRUCTURES, Yiyu Lin and L. Shafai, Department of Electrical Engineering, University of Manitoba, Winnipeg, Canada

4. EFFICIENT SOMMERFELD INTEGRAL COMPUTATION WITH APPLICATIONS TO PRINTED CIRCUIT ANTENNAS, P. B. Katehi and N. G. Alexopoulos, Electrical Engineering Department, University of California, Los Angeles, CA

5. ANALYSIS OF A CIRCULAR PATCH ANTENNA ON A DIELECTRIC COVERED CONDUCTING SPHERE, Probir K. Bondyopadhyay, Department of Electrical

Engineering and Computer Science, New York Institute of Technology, Old Westbury, NY

6. EXCITATION OF A RESONANT CYLINDRICAL DIELECTRIC CAVITY ANTENNA THROUGH A MICROSTRIP LINE, N. K. Uzunoglu, Department of Electrical Engineering, National Technical University of Athens, Greece

7. A METHOD OF ANALYZING DIELECTRIC RESONATORS IN MICROWAVE CIRCUITS, Qizheng Gu, Research Laboratory of Electronics, Massachusetts Institute of Technology, Cambridge, MA

8. DOUBLE VARIATIONAL FORMULATION OF A STRIPLINE Y-JUNCTION, David C. Chang, Department of Electrical and Computer Engineering, University of Colorado, Boulder, CO

9. SINUSOIDALLY MODULATED FILTERS, N. V. Nair, Department of Electronics & Communication Engineering, College of Engineering, Trivandram, India, A. K. Mallick, Department of Electronics and Electrical Communication Engineering, Indian, Institute of Technology, Kharagpur, India

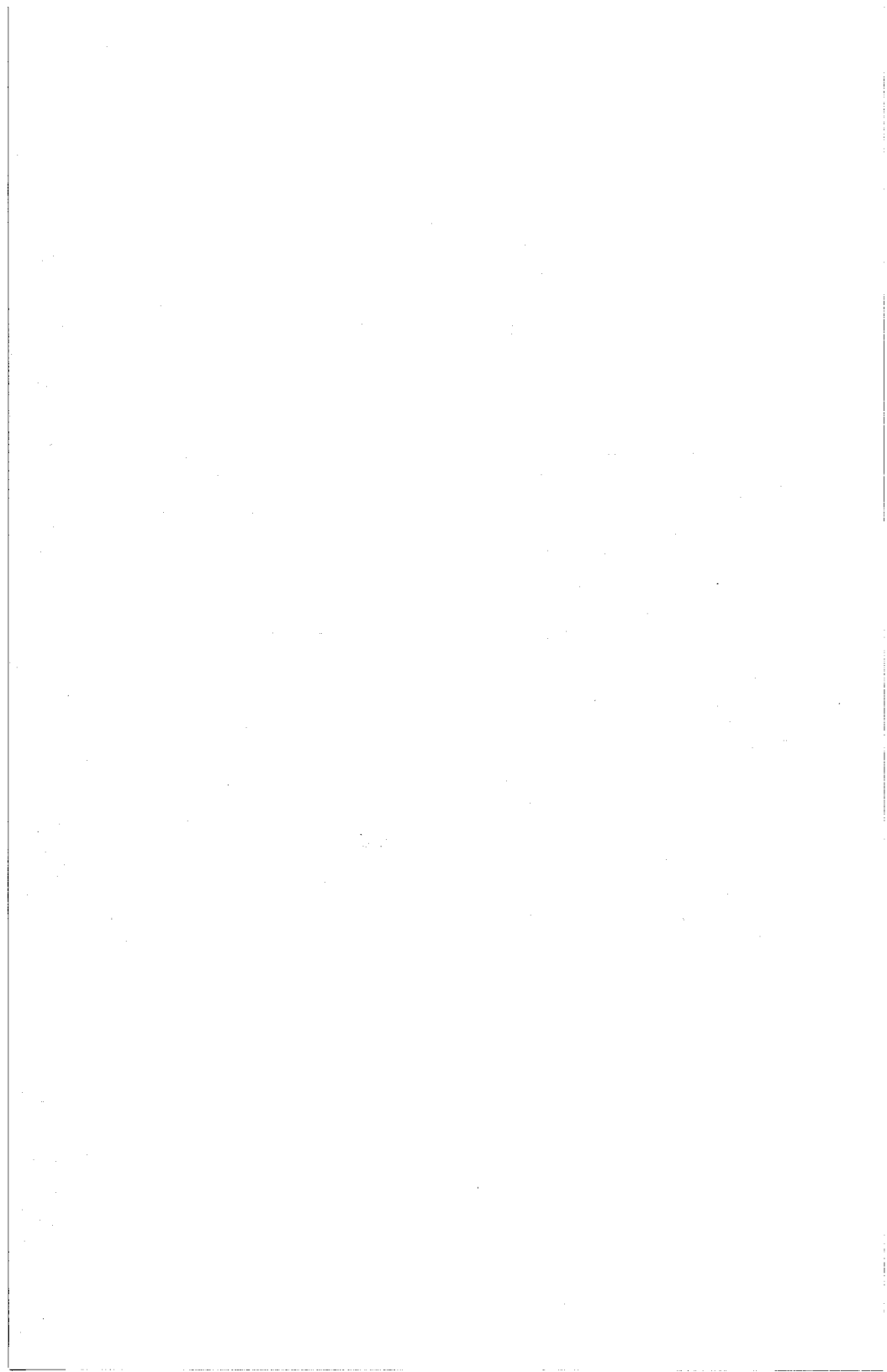

AN EFFICIENT MOMENT METHOD ANALYSIS OF
INFINITE MICROSTRIP ARRAYS

S. M. Wright and Y. T. Lo
Department of Electrical Engineering
University of Illinois
1406 W. Green St.
Urbana, Illinois 61801

This paper describes a numerically efficient moment method technique which is applicable to a wide class of periodic problems. Large periodic structures such as phased arrays or frequency selective surfaces are typically modeled as infinite and analyzed using the method of moments in the spectral domain. This approach has the advantage of simple formulation at the expense of requiring the evaluation of extremely slowly convergent doubly infinite series to compute the elements of the general impedance matrix. This is an important difficulty because it can limit the number of expansion functions used, or lead to the use of entire domain basis functions, which can reduce the generality of the solution.

The method described here also begins with a spectral domain moment method approach, using the periodic Green's function for a particularly simple formulation. However, an acceleration technique (W.F. Richards *et. al.*, Proc. URSI Symp., May 23-26, 1983, and S.M. Wright *et. al.*, *ibid.*) is used to evaluate the resultant doubly infinite series. The benefits of applying the acceleration technique to this type of problem are the greatly decreased time required to evaluate the matrix elements, and the ease in handling the singularity in the Green's function. The $1/R$ singularity is dealt with in the space domain, where many numerical techniques exist to evaluate it efficiently.

This technique has been applied to the analysis of infinite arrays of microstrip dipoles and patches, both with and without dielectric radomes. For generality subsectional basis and testing functions were chosen. In general, rooftop basis functions were used, but the use of basis functions employing an edge condition will be discussed. In addition, the application of thin wire approximations to the narrow dipole will be discussed, and the impedance of microstrip arrays versus scan angle will be shown. The presence of blind angles is clearly shown. Finally, results will be given for the impedance of thick microstrip patch arrays, including the effects of various parameters such as frequency and thickness of the dielectric substrate.

URSI/B-11-2

ANALYSIS OF A LINEAR MICROSTRIP ARRAY COUPLED BY MICROSTRIP TRANSMISSION LINES

E.H. Newman and J.E. Tehan
The Ohio State University ElectroScience Laboratory
Department of Electrical Engineering
Columbus, Ohio 43212

The problem to be analyzed is a linear array of N rectangular microstrip antennas printed on a grounded dielectric slab. The array is to be fed at a single input port on element 1. The microstrip elements are connected in series by microstrip transmission lines extending from the output port of element 1 to the input port of element 2, the output port of element 2 to the input port of element 3, etc. The microstrip array plus its microstrip transmission line feed network can be analyzed via a generalized Thevenin's theorem.

As described above, each array element is considered to have an input and an output port. Thus, the array can be considered as a $2N$ port network. In the absence of the microstrip transmission line feed network, the array could be described by a $2N \times 2N$ open-circuit impedance matrix referenced to the $2N$ feed ports. The computation of this matrix requires a method of moments (MM) analysis of the array with the feed network removed. This MM solution employs the exact slab Green's function and includes effects of surface waves and electromagnetic (as opposed to transmission line) coupling between the elements. The transmission line feed network can also be described by a $2N \times 2N$ open-circuit impedance matrix referenced to the $2N$ feed ports. Finally, the matrices for the isolated array elements and the isolated feed network are added to produce a Thevenin equivalent impedance matrix for the array elements plus the transmission line feed network. One can then follow the recipe of the Thevenin's theorem to analyze the entire microstrip array.

Numerical and experimental results will be presented which compare the input impedance of various array configurations. These results indicate that although the array elements are connected in series by the transmission lines, they appear to be in parallel as viewed from the input port.

This work was supported by the U.S. Army Research Office, P.O. Box 12211, Research Triangle Park, North Carolina 27709, under Grant No. DAAG29-81-K-0020.

NUMERICAL SOLUTION OF RADIATION FROM
MICROSTRIP STRUCTURES

Yiyu Lin and L. Shafai

Department of Electrical Engineering
University of Manitoba
Winnipeg, Manitoba, Canada R3T 2N2

Integral equations for both interior and exterior fields of microstrip lines and antennas are formulated in terms of the tangential electric and magnetic field distributions, over the conducting and dielectric substrate surfaces. The boundary conditions are applied and a set of integral equations for the above surface distributions is obtained. It is shown that using a moment method, this set of integral equations can be reduced to a matrix equation, a solution of which gives the required surface field distributions.

The method is then applied to investigate the radiation by square and rectangular patch microstrip antennas. The computed far field data are compared with those of the experimental and approximate analytic methods, already available for investigation of such antennas. Satisfactory results, within a wide range of frequency variations, are obtained. Details of the method and its results will be discussed during the presentation.

URSI/B-11-4

EFFICIENT SOMMERFELD INTEGRAL COMPUTATION WITH
APPLICATIONS TO PRINTED CIRCUIT ANTENNAS

BY:

P. B. KATEHI AND N. G. ALEXOPOULOS
ELECTRICAL ENGINEERING DEPARTMENT
UNIVERSITY OF CALIFORNIA
LOS ANGELES, CALIFORNIA 90024

ABSTRACT

Printed dipoles and microstrip patches excited either by a probe or a gap generator or a microstrip transmission line can be solved by applying Moments Method to Pocklington Integral Equation. The use of the dielectric slab Green's function involves the numerical evaluation of Sommerfeld-type integrals which together with the evaluation of the space integrals introduced by Moments Method originally result in a computationally inefficient solution.

In order to eliminate the above difficulty, finite thickness antennas are considered while the slow convergent integrals can be evaluated quite efficiently by using a combination of numerical and analytical techniques. The semi-infinite Sommerfeld Integrals (λ being the variable of integration) combined with the triple space-Integrals introduced by Moments Method are split into two parts, one that involves integration with respect to λ from 0 to A (A being a very big number) while in the other one the λ -integration has been evaluated in a closed form. A transformation of the space integrals into a fast convergent series combined with numerical and analytical integrations is used successfully for the evaluation of the integrals resulting in a very accurate and computationally efficient solution of microstrip antennas.

Numerical results based on the above method are presented and the accuracy together with the efficiency of the solution are discussed.

ANALYSIS OF A CIRCULAR PATCH ANTENNA ON A DIELECTRIC
COVERED CONDUCTING SPHERE

by

Probir.K.Bondyopadhyay
Dept. of Electrical Engineering
and Computer Science
New York Institute of Technology
Old Westbury, New York 11568

The problem of a radiating conducting circular patch antenna mounted on a dielectric covered conducting sphere has been investigated. This radiating structure has applications in the analysis and design of ground based and airborne conformal phased array antennas.

The analysis is based on field representations in the spherical regions in terms of spherical waveguide modes. Spherical transmission line relations are used to transform spherical mode impedances from one plane to another. An integral equation formulation of the problem is solved by the moment method. Basis functions that satisfy edge conditions on the patch have been used in the analysis.

Numerical computations have been made for the resonant characteristics of the structure for different dielectric thickness, dielectric constants, circular patch and sphere sizes. Radiation patterns have been computed. Previous works done for the planar and cylindrical geometries have been consulted for this investigation.

This work has been supported by a research grant from the New York Institute of Technology.

URSI/B-11-6

Excitation of a Resonant Cylindrical Dielectric Cavity Antenna through a Microstrip line

N.K.Uzunoglu
Department of Electrical Engineering
National Technical University of Athens
Athens 10682, Greece

ABSTRACT

The radiation properties of a resonant cylindrical dielectric antenna coupled to a microstrip line is investigated both analytically and experimentally. The geometry of the problem is shown in figure 1 where a finite dielectric cylinder is used to radiate the incident guided wave into free space. An integral equation system is written for the unknown electric field inside the dielectric cavity and the current distribution on the microstrip line. In order to solve this system of equations the electromagnetic field inside the cavity is expanded in terms of the normal modes while the current on the microstrip line is approximated as a superposition of the incident and reflected quasi-TEM mode currents plus a terminal zone current distribution. After determining the electric field distribution inside the dielectric cavity the input impedance observed on the microstrip line is computed by using the basic integral equation. Radiated far-field distributions are obtained by applying a stationary phase integration technique. In the resonance frequency region of the cylindrical cavity normal modes approximate analytical results are derived for the input impedance observed on the microstrip line. Numerical computations are being performed for several antenna geometries to deduce optimum design criteria for the a/d , ϵ_r/ϵ_r' , c/d ratios (see fig.1) in terms of the radiation resistance, antenna bandwidth and efficiency. In order to check the validity of the theoretical results an experimental dielectric cavity antenna is constructed and its input impedance is measured as well its radiation pattern at 24GHz.

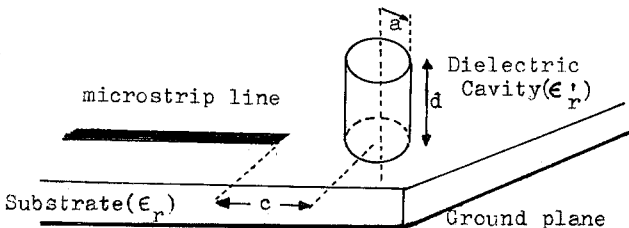

Fig.1. Microstrip fed dielectric cavity antenna.

A METHOD OF ANALYZING DIELECTRIC RESONATORS
IN MICROWAVE CIRCUITS

Qizheng Gu
Research Laboratory of Electronics
Massachusetts Institute of Technology
Cambridge, Massachusetts 02139

This paper describes a general method of analyzing dielectric resonators in microwave circuits by means of lumped element equivalent circuits deduced from the electromagnetic theory. Based on this method, we study several frequently used basic circuits including direct coupling between two adjacent resonators in a cut-off waveguide, coupling between a microstrip transmission line and a dielectric resonator, and a circuit of frequency stabilized microwave oscillator using dielectric resonators. Formulas and curves that can be applied to designing circuits are presented.

Since the field distributions of the dominant modes for rectangular and cylindrical dielectric resonators are quite similar to those of magnetic dipoles, the dielectric resonators operating at their dominant modes may be modelled with conducting resonance loops consisting of an inductor L_r and a capacitor C_r carrying current I_r . Making use of the approximate field distribution of dielectric resonators, we obtain the principal parameters of the corresponding circuits, such as the coupling coefficient between two resonators in a cut-off waveguide and the coupling coefficient for a resonator and a microstrip line, which are useful in the design of microwave circuits.

The results obtained from this method are shown to compare favorably with experimental data. The errors are less than 5%. Although the accuracy for this method is limited, it has the distinct advantage of applicability to varied cases in complicated microwave circuits.

DOUBLE VARIATIONAL FORMULATION
OF A STRIPLINE Y-JUNCTION

David C. Chang
Department of Electrical and Computer Engineering
University of Colorado
Boulder, Colorado 80309

In the design of stripline circuits, it is important to know the scattering and mismatch losses of junctions resulting from branching of the circuits. However, because the boundary-value problem of a typical junction usually involves semi-infinite lines with a configuration that do not match well with any global coordinate system, its formulation has long defied a rigorous theoretical or numerical solution. As a result, design application has been limited to low-frequency and/or less complex circuit configuration where the use of basic transmission-line analysis yields satisfactory, zeroth-order solution. Correction due to spurious radiation and mismatch at the junctions is then treated on an *ad hoc* basis. For instance, radiation loss can be computed from the time-average Poynting vector associated with an assumed current distribution on the lines and integrating over the entire half-space.

In this work, the problem of a stripline junction is tackled approximately using a modified double variational technique, originally proposed by Vainshtein and his colleagues in their treatment of a thin-wire dipole antenna of finite length and a transmission-line bend (L.A. Vainshtein, *Sov. Phys. Tech. Phys.*, 6, 19-29, 1961); (Arutyunyan, et al., *Radio Eng. Electron. Phys.*, 22, 10, pp. 2195-2198, 1977). Starting with a known result obtained by the Wiener-Hopf technique for a semi-infinitely long stripline, we can demonstrate how a similar result for the reflected current from the end of the stripline can be deduced asymptotically from the variational formulation. The same technique is then applied to a stripline Y-junction to obtain the scattering matrix associated with the junction. Since the zero-order information regarding the mismatch junction can be obtained easily from the transmission-line analysis, we can show that the double variational technique indeed provides an accurate assessment of the spurious radiation and dynamic junction reactances. For striplines and other thin-wire transmission-line structures, the resultant expression for the scattering matrix in fact can be derived in close-form in terms of exponential integrals. Extension to the microstrip junction will be addressed in the presentation.

SINUSOIDALLY MODULATED FILTERS

N.V. NAIR

Department of Electronics &
Communication Engineering,
College of Engineering,
Trivandram -695016 INDIA.

A.K. MALLICK

Department of Electronics
& Electrical Comm. Engg.
Indian Institute of
Technology,
Kharagpur - 721 302, INDIA.

Summary

The properties of the modulated periodic structures with periodicity, P and depth of modulation, m have been exploited in the design and construction of microstrip filters as a (a) band-reject filter and (b) bandpass filter. Two configurations have been considered :
(i) Sinusoidally width-modulated (N.V. Nair et al, MTT, Feb. 1984) and (ii) sinusoidally impedance level modulated microstrip lines.

For (a), a set of design curves has been constructed relating the centre frequency (f_0) of a stopband with P and the width (Δf) of the stopband with m , for either (i) or (ii). The design of a band-reject filter with $f_0 = 5.3$ GHz and $\Delta f = 2.35$ GHz has been made on a substrate with $\epsilon_r = 10.2$ and $h = 0.635$ cm. Design values are average width, $W_0 = 0.25$ cm, $P = 1$ cm, and $m=0.6$. Eight periodic cells are chosen. The experimental filter gives an insertion loss of 44.5 dB, a shift in f_0 of 0.05 GHz, and a bandwidth of 2.4 GHz. The response exhibits steep skirts. The design has been repeated for (ii).

For (b), initial design has been carried out for quarter-wave coupling with staggered parallel coupled, half-wavelength stepped impedance resonators. Each resonator of half wavelength has two half sections, one with 50 ohm impedance and the other 35 ohm. The sinusoidally modulated filter has been derived from this. Stepped impedance resonator filter is designed for $f_0 = 6$ GHz, No. of resonator = 4, response = chebyshev, relative bandwidth = 0.04. The mean width W_0 of the modified sinusoidal filter is cosinusoidally modulated to the depth, m and $P = 5$ cm, corresponding to 50 ohm and 35 ohm step widths. The experimental filter exhibits a centre frequency of 6.02 GHz, a bandwidth of 240 MHz and midband insertion loss of 3.8 dB. It has a steep skirts response, and attenuation better than 75 dB below and 60 dB above the passband has been observed.

The study clearly shows that modulated filters provide an added flexibility in the filter design by controlling the values of m and P of the modulated structure. Yet, they maintain a marked superiority to conventional types of filters.

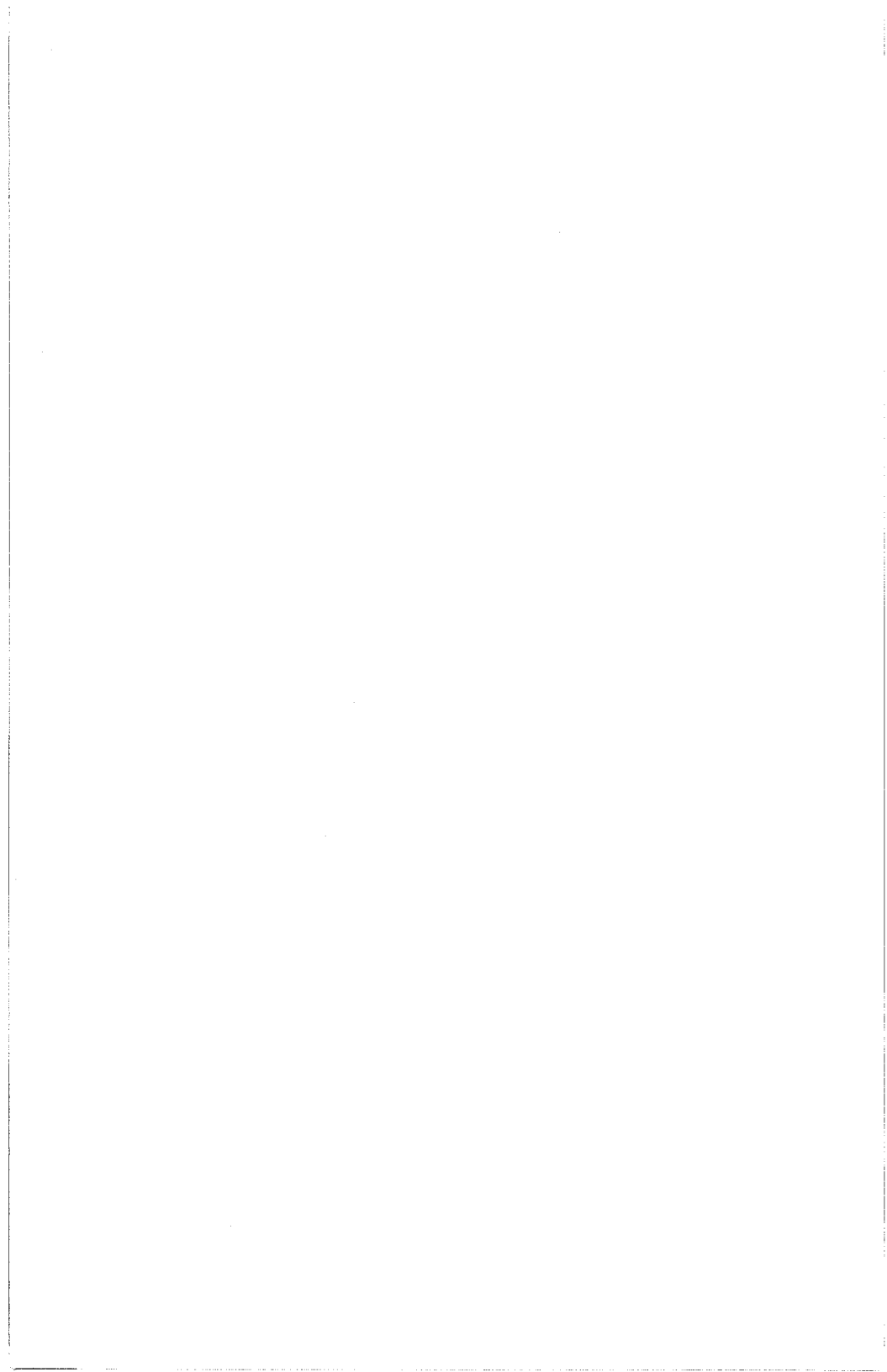

**URSI COMMISSION F SESSION F-2
MODELLING AND MEASUREMENT
OF PROPAGATION EFFECTS**

Tuesday, June 26 1:30 - 5:00 P.M.

Room: ST. GEORGE A, B

Chairman: Julius Goldhirsh
Johns Hopkins A.P.L., Laurel, MD

1. RAIN RATE MODEL FOR INDIA, P.N. R. Setty, O.P.N. Calla and R. Singh, Space Applications Centre, Indian Space Research Organization, Ahmedabad, India, R. K. Crane, Thayer School of Engineering, Dartmouth College, Hanover, N.H.

2. INVESTIGATION OF THE TWO-COMPONENT RAIN ATTENUATION MODEL FOR USE IN SATELLITE SYSTEMS, Michael A. Kremer and Robert K. Crane, Thayer School of Engineering, Dartmouth College, Hanover, N.H.

3. AN EXTENSION OF THE TWO-COMPONENT RAIN MODEL TO CONSIDER VARIABILITY OF ATTENUATION, FADE DURATION, AND SITE DIVERSITY STATISTICS, Richard W. Cavanaugh and Robert K. Crane, Thayer School of Engineering, Dartmouth College, Hanover, N.H.

4. REVISION OF THE TWO-COMPONENT MODEL TO INCLUDE THE SPATIAL CORRELATION OF RAIN, Horng-Chung Shieh and Robert K. Crane, Thayer School of Engineering, Dartmouth College, Hanover, N.H.

5. MEASUREMENT OF LOW-ALTITUDE WIND VELOCITY BY GROUND-BASED RADIOMETRY, Giovanni Abramo, Giorgio Apponi, Piero Ciotti, Dipartimento di Elettronica, Università di Roma "La Sapienza,"

Roma; Italy, Domenico Solimini, Dipartimento di Ingegneria Elettronica, Università di Roma "Tor Vergata," Roma, Italy

6. DIFFERENTIAL REFLECTIVITY MEASUREMENTS OF PRECIPITATION AT WALLOPS ISLAND, VIRGINIA, Julius Goldhirsh and John R. Rowland, The Johns Hopkins University Applied Physics Laboratory, Laurel, MD

7. SLANT PATH RAIN ATTENUATIONS AT 28 GHz DERIVED SIMULTANEOUSLY WITH A RADIOMETER AND A RADAR, Julius Goldhirsh, The Johns Hopkins University Applied Physics Laboratory, Laurel, MD

8. 800 MHz: ATTENUATION MEASURED IN AND AROUND SUBURBAN HOUSES, D. C. Cox and R. R. Murray, The Regional Bell Operating Companies, Holmdel, N.J., A. W. Norris, AT&T Bell Laboratories, Holmdel, N.J.

9. AN OPTICAL DISDROMETER TO MEASURE DROPSIZE DISTRIBUTIONS, VISIBILITY AND LIQUID WATER CONTENT IN AN AIRBORNE ENVIRONMENT, Ella Dobson, John Rowland, Maynard Hill and Robert Miller, The Johns Hopkins University Applied Physics Laboratory, Laurel, MD

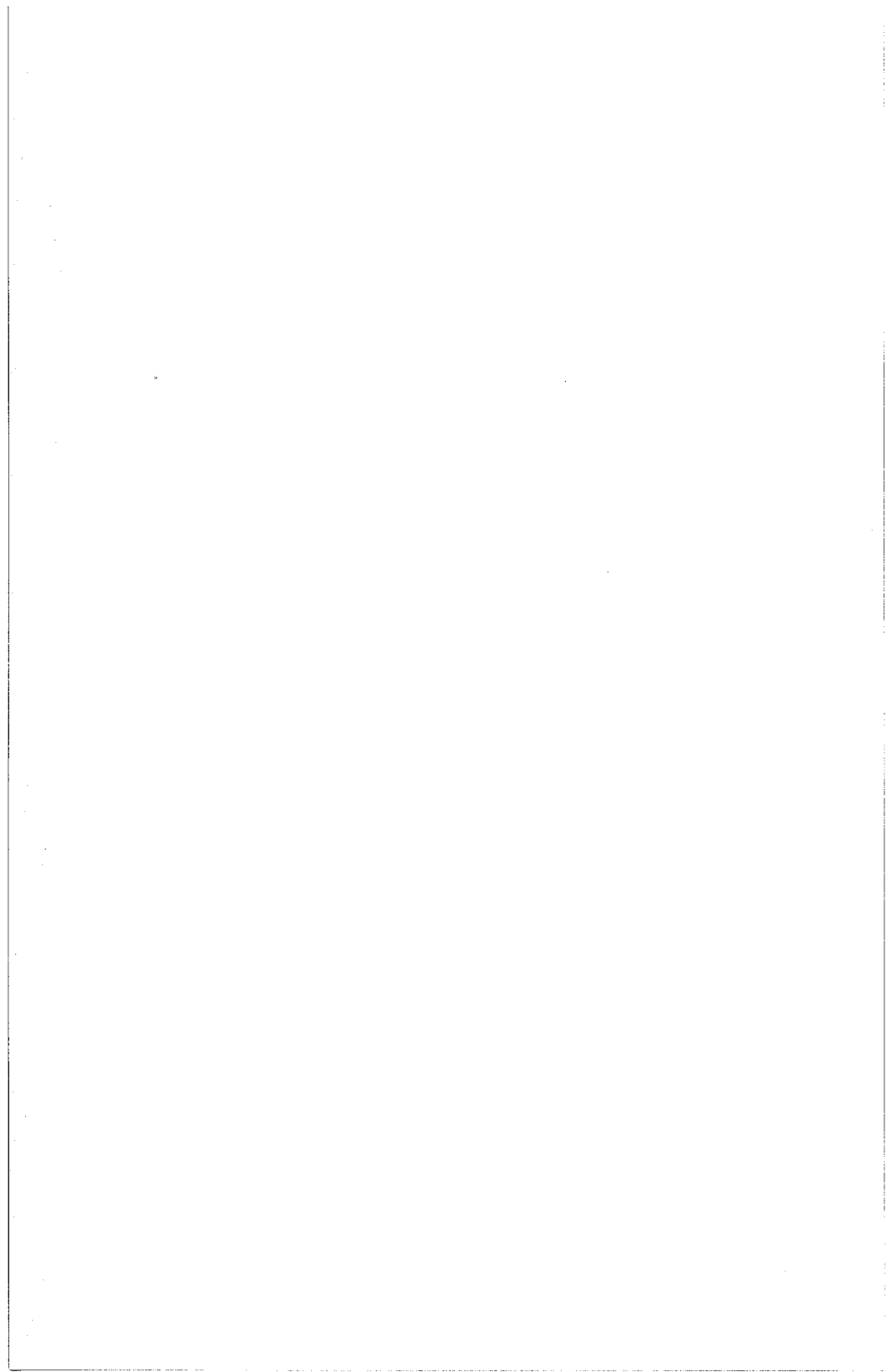

RAIN RATE MODEL FOR INDIA

P.N.R. Setty*, R.K. Crane**, O.P.N. Calla* and R. Singh*

*Space Applications Centre, Indian Space Research Organization
Ahmedabad - 380053, India

**Thayer School of Engineering, Dartmouth College, Hanover, N.H. 03755
U.S.A.

Attenuation due to rain can be computed for slant and terrestrial paths for places where point rain rate statistics are not available by using rain-rate climate models. Available models such as the CCIR and Crane-Global models divide India into only two regions and are not adequate to describe the wide range of climates present in the country. A new rain-rate climate model was developed for India using 233 station-years of hourly rainfall data from 26 locations. The data for each location and specified annual exceedence probability value were found to follow a log-normal distribution. Employing the log-normal model for the year-to-year variation in the annual rain rate distribution values, an average annual distribution was constructed for each location. A 3-parameter log-normal model and a 5-parameter two-component model were best fit to each of the annual distributions. A cluster analysis was applied to the 3-parameter model coefficients to identify geographically contiguous rain climate zones.

Nine climate regions were found to describe adequately the observed hourly rainfall distributions. Pooled data from each climate region were combined to generate rainfall distributions. The pooled distributions were used to fit the 3- and 5- parameter distribution models. The rms errors for the log-normal model were less than 15 percent and the errors for the two-component model were less than 13 percent. Data from individual locations differed from the best fit climate distributions by less than 30 percent for the log-normal model and 26 percent for the two-component model for annual probabilities ranging from 0.01 to 1.0 percent. For rain attenuation analysis, the hourly rain accumulation distributions were transformed to 1 - minute average rain-rate distributions using a power-law relationship.

URSI/F-2-2

INVESTIGATION OF THE TWO-COMPONENT RAIN ATTENUATION MODEL FOR USE IN SATELLITE SYSTEMS

Michael A. Kremer and Robert K. Crane
Thayer School of Engineering
Dartmouth College
Hanover, N.H. 03755

The project investigates the two-component rain attenuation model developed by R.K. Crane. Three parts are considered (1) the dependency of the five model parameters on local climatological data; (2) the variation of the observed rain rates about the value predicted by the model; and (3) the ramifications on the model of using 30 or 60 second "instantaneous" average rain rate data.

Currently, the world is partitioned into twelve rain climate zones, resulting in appreciable rain rate variability within each zone. By establishing a dependency between local climatological data and the five parameters of the model, a method for interpolating the rain rate distribution within each zone is produced. The variation of observed rain rate data about the model is most important at the higher rain rates. To extend the model to predict this variation and to establish confidence limits, the statistics of extremes is considered. Finally, to obtain 60 second "instantaneous" rain rate data, a power-law transformation is used. This allows the model to fit 60 second rain rate data as a basis of comparison with the fitted curves obtained with longer integration times - 5, 10 and 60 minutes.

AN EXTENSION OF THE TWO-COMPONENT RAIN MODEL TO CONSIDER VARIABILITY OF ATTENUATION, FADE DURATION, AND SITE DIVERSITY STATISTICS

Richard W. Cavanaugh and Robert K. Crane
Thayer School of Engineering
Dartmouth College
Hanover, N.H. 03755

The future growth of the satellite communications industry is limited by its scarce resources: the orbital arc and frequency spectrum. Higher frequencies have been assigned to satellite systems to accommodate future growth. Rain fading affects the reliability of systems in the 10 to 50 GHz range. Prediction of the amount of attenuation to be exceeded for various percentages of the year and fade duration statistics are important in frequency allocation and system design at the higher frequencies. Site diversity serves to increase the reliability of communication in areas of heavy rainfall. Unbalanced site diversity (different antenna sizes at diversity locations) may make site diversity cost-effective. An understanding of the effects of radio interference is necessary for frequency allocation and the orbital spacing of satellites. The two-component model, which presently predicts median values of attenuation for various percentages of the year, is structured for an extension to the above considerations. The model was modified to predict the variability of one year attenuation, fade duration, and site diversity distribution observations. This work provides a foundation for future interference models.

URSI/F-2-4

REVISION OF THE TWO-COMPONENT MODEL TO INCLUDE THE SPATIAL CORRELATION OF RAIN

Horng-Chung Shieh and Robert K. Crane
Thayer School of Engineering
Dartmouth College
Hanover, N.H. 03755

Attenuation due to rain has long been recognized as a major limitation to reliable communication system operation at frequencies above 10 GHz. For design purpose, a simple prediction model is required because long term observations are not available for most areas. A new model is presented to calculate the probability of exceeding specific attenuation values on terrestrial and earth-satellite diversity paths.

This model is based on the assumptions and parameters of Crane's two-component model which considered cell and debris as independent sources contributing to rain attenuation. A prediction procedure was developed employing spatial correlation functions for each rain climate region to represent the spatial variations of the two components. The correlation functions are determined by the meteorological structure of rain.

The diversity prediction performance of this new model is compared with observed data and with the performance of the two-component model, the Hodge model, the Allnutt and Rogers model and the Morita-Higuti model. The results of comparison show that the new model provides an improvement over the earlier models.

MEASUREMENT OF LOW-ALTITUDE WIND VELOCITY BY
GROUND-BASED RADIOMETRY

Giovanni Abramo, Giorgio Apponi, Piero Ciotti
Dipartimento di Elettronica, Università di Roma "La Sapienza"
Via Eudossiana 18, 00184 Roma, Italy

and

Domenico Solimini
Dipartimento di Ingegneria Elettronica, II Università di Roma
"Tor Vergata", Via O. Raimondo, 00173 Roma, Italy

The characteristics of the space-time fluctuations of the received field propagated along a tropospheric path depend on the velocity of the wind carrying the inhomogeneities of the refractive index across the electromagnetic path. Several measurement techniques based on this effect have been proposed both at optical (Wang, Ochs, and Lawrence, Appl. Opt. 20, 4073-4081, 1981) and at microwave frequencies (d'Auria and Solimini, Int. J. Remote Sensing 4, 385-398, 1983). On the other hand, the radiative intensity of the atmospheric thermal emission reaching a radiometer is a function of the distribution of temperature and absorption in the atmosphere. The motion of the air results in local fluctuations of the meteorological variables and, in turn, in fluctuations of the output of the radiometer. The characteristics of the space-time fluctuations of the atmospheric radiance depend on the velocity of the wind carrying the absorptive and thermal inhomogeneities across the radiometer beam. This effect suggests the feasibility of passive techniques for measuring the wind velocity.

Under suitable hypotheses, the temporal spectrum of the radiometric signal is related to the structure constant and to the spatial spectral density of the atmospheric temperature fluctuations and to the wind velocity. The asymptotic expressions of the spectrum of the radiometric signal for low and high frequencies have been worked out for a frozen Kolmogorov turbulence. The asymptotes meet at a breakpoint frequency which, for a given weighting function, is shown to be proportional to the wind velocity. The breakpoint frequency method for measuring the low-altitude wind velocity has been tested by use of a ground-based infrared radiometer. The accuracy of the experimental data, which have also been compared with those obtained by the autocovariance technique, is discussed.

URSI/F-2-6

DIFFERENTIAL REFLECTIVITY MEASUREMENTS OF PRECIPITATION AT WALLOPS ISLAND, VIRGINIA

Julius Goldhirsh and John R. Rowland
The Johns Hopkins University
Applied Physics Laboratory
Johns Hopkins Road
Laurel, Maryland 20707

A dual polarization switch has been installed on the SPANDAR radar at Wallops Island, Virginia enabling the remote sensing of precipitation for both the vertical and horizontal polarizations. Injecting the near simultaneous echoes at both polarizations into an appropriate two parameter algorithm for rain drop size distribution, we may estimate the rain drop size distributions within the various radar pulse volumes. This technique pioneered by T. A. Seliga and V. N. Bringi (Radio Science, Vol. 13, No. 2, pp. 271-275, 1978) is known as the differential reflectivity method. A knowledge of the drop size distributions enable the estimation of the rain rate, liquid water content, and the attenuation coefficients at various frequencies.

In this paper we report on our preliminary experimental results involving the determination of the radar derived rain rates and drop size distributions and comparison with those deduced with disdrometers and raingages located in the vicinity of a given radar pulse volume.

Also described is an examination of the differential reflectivity algorithms when applied to a disdrometer data base involving rain events during several days and the measurements of hundreds of drop size spectra.

SLANT PATH RAIN ATTENUATIONS AT 28 GHz DERIVED
SIMULTANEOUSLY WITH A RADIOMETER AND A RADAR

Julius Goldhirsh
The Johns Hopkins University
Applied Physics Laboratory
Johns Hopkins Road
Laurel, Maryland 20707

Slant path rain attenuations at 28.56 GHz have been individually estimated employing a radiometer system and a single polarization S band radar at Wallops Island, Virginia. Ancillary insitu measurements are also made employing a disdrometer and a raingage system. Drop size distributions derived from the disdrometer are injected into a radar prediction method enabling the determination of the path attenuation. Path attenuation statistics covering a 5 day period have been determined for both the radar and radiometer cases.

The major results of this investigation are: (1) The radiometer may be used at the low levels of attenuation to fine tune the radar prediction capabilities. (2) The radar may be used to clarify the nature of the radiometer measurements, especially when it is not raining at the site. (3) The radar and radiometer derived attenuations track each other at the lower fade levels (smaller than 8 dB) showing relatively good overall agreement. (4) The cumulative conditional fade distributions for both the radar and radiometer cases are generally within a small fraction of a dB of one another up to 10 dB.

As uncertainties in the estimation of path attenuation exist for both the radar and radiometer techniques, it is demonstrated that both systems may complement each other giving rise to improved predictabilities for both.

URSI/F-2-8

800 MHZ ATTENUATION MEASURED IN AND AROUND SUBURBAN HOUSES

D. C. COX AND R. R. MURRAY
CENTRAL SERVICES ORGANIZATION OF
THE REGIONAL BELL OPERATING COMPANIES
HOLMDEL, NEW JERSEY

A. W. NORRIS
AT&T BELL LABORATORIES
HOLMDEL, NEW JERSEY

Signal levels around and within eight suburban houses have been measured at 800 MHz. These measurements are needed in refining the requirements for portable radio communication systems that can accommodate low-power radiotelephone sets. The measurements were made from an instrumentation van having an erectable 27 foot high antenna. Large-scale distributions of the small-scale signal medians are approximately log-normal. The decrease in median signal level with distance ranges from d^{-3} to $d^{-6.2}$ for the eight houses. Signal decreases as $d^{-4.5}$ for the overall data set. At 1000 feet, regressions to signal levels range from 12.5 dB to 37.1 dB below free space propagation levels for locations outside and locations inside on first and second floors. In basements, regression levels at 1000 feet range from 29 dB to 48.2 dB below free space. For the overall data set, regression signal levels at 1000 feet are 27.7 dB below free space. For all the basements, this value is 39.6 dB.

AN OPTICAL DISDROMETER TO MEASURE DROPSIZE DISTRIBUTIONS, VISIBILITY AND LIQUID WATER CONTENT IN AN AIRBORNE ENVIRONMENT

Ella Dobson, John Rowland, Maynard Hill, and
 Robert Miller
 The Johns Hopkins University
 Applied Physics Laboratory
 Laurel, Maryland 20707

Many methods have been developed over the years to measure the size distributions $N(d)$ of particles in various media. These techniques range from simple exposure of dyed paper to liquid drops to the use of elaborate optical systems. Despite the many instruments developed and successfully used to measure $N(d)$ of such things as jet fuel sprays, cement particles, pollen and seeds, there are few instruments capable of measuring $N(d)$ in an airborne environment in real time. Of the instruments available none can be considered inexpensive. This paper discusses a low cost optical disdrometer that is capable of measuring either drop size distribution in cloud, fog or rain which allows computation of liquid water content (LWC) and visibility (V) or LWC and V can be obtained directly without computation of drop size

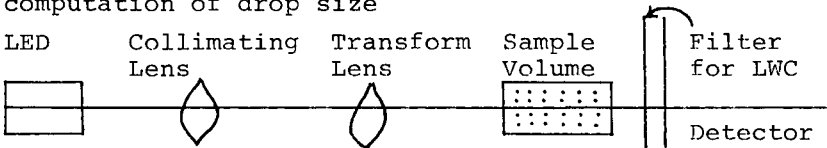

An illustration of the instrument is shown in figure 1. The principle for the system is found in scalar diffraction theory. When many particles of various sizes are present in the volume, a combination of diffraction patterns is superimposed in the image plane. This pattern can be expressed analytically as the product of a vector and a matrix where the elements of the vector are the number of drops in each category and the matrix elements are calculable when the system geometry and calibration are known. The solution of this matrix equation gives $N(d)$. If one only wants visibility, which is proportional to $\sum d_i^2$ (d_i is drop diameter), then it suffices to integrate the intensity over the entire diffraction pattern. Similarly, by placing the appropriate filter in front of the image plane and integrating over the pattern, one obtains a value portional to $\sum d_i^3$ which gives LWC.

A description of the instrument and results obtained to date will be discussed.

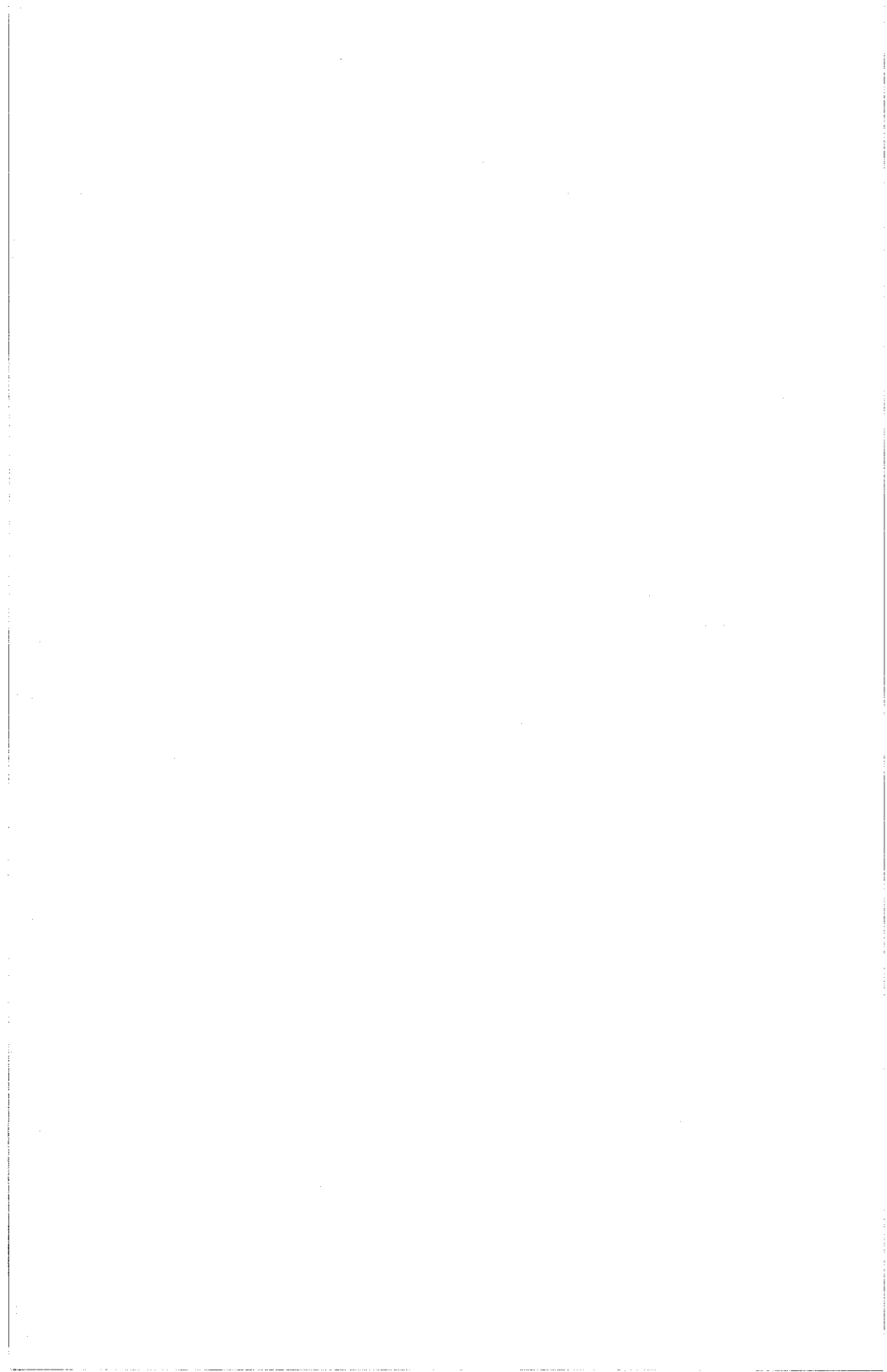

URSI COMMISSION B SESSION B-12

NUMERICAL METHODS I

Wednesday, June 27 1:30 - 5:00 P.M.

Rooms: ESSEX NORTH WEST

Chairman: William F. Richards

University of Houston, Houston, Texas

1. DETECTION OF BRANCH POINTS BY MODIFIED FFT, Fung I. Tseng and Tapan K. Sarkar, Department of Electrical Engineering, Rochester Institute of Technology, Rochester, NY

2. SOME COMMENTS ON EFFICIENT USE OF FFTS AND RELATED OPERATIONS IN SCATTERING AND DIFFRACTION CALCULATIONS, W. Ross Stone, IRT Corporation, La Jolla, CA

3. FAST CONVERGENT SOLUTIONS OF STRIP GRATINGS, Te-Kao Wu, Hughes Aircraft Company, Space and Communications Group, Los Angeles, CA

4. NUMERICAL REGULARIZATION AND THE SPECTRAL ITERATIVE TECHNIQUE, S. S. Chaiken, TRW, Redondo Beach, CA

5. A COMPARISON BETWEEN THE SPECTRAL ITERATIVE METHOD (SIT) AND THE CONJUGATE GRADIENT METHOD UTILIZING FFT, Tapan K. Sarkar, Department of Electrical Engineering,

Rochester Institute of Technology, Rochester, NY

6. APPLICATION OF THE SPECTRAL-ITERATION APPROACH AND THE CONJUGATE GRADIENT METHOD TO THE PROBLEM OF SCATTERING BY STRIPS OF ARBITRARY WIDTH AND FOR E- OR H-WAVE INCIDENCE, W. L. Ko, University of Louisville, Louisville, KY, R. Mittra, University of Illinois, Urbana, IL

7. CONJUGATE GRADIENT SOLUTION OF ARBITRARY PLANAR FREQUENCY SELECTIVE SURFACES, J. P. Montgomery and K. R. Davey, Georgia Institute of Technology, Engineering Experiment Station, Atlanta, GA

8. STUDY ON THE SCATTERING FIELD OF A RECTANGULAR DIELECTRIC SHELL WITH A PLANE WAVE INCIDENCE, Nai-hua Sun and Han-kui Chen, Microwave Research Laboratory, East China Normal University, People's Republic of China

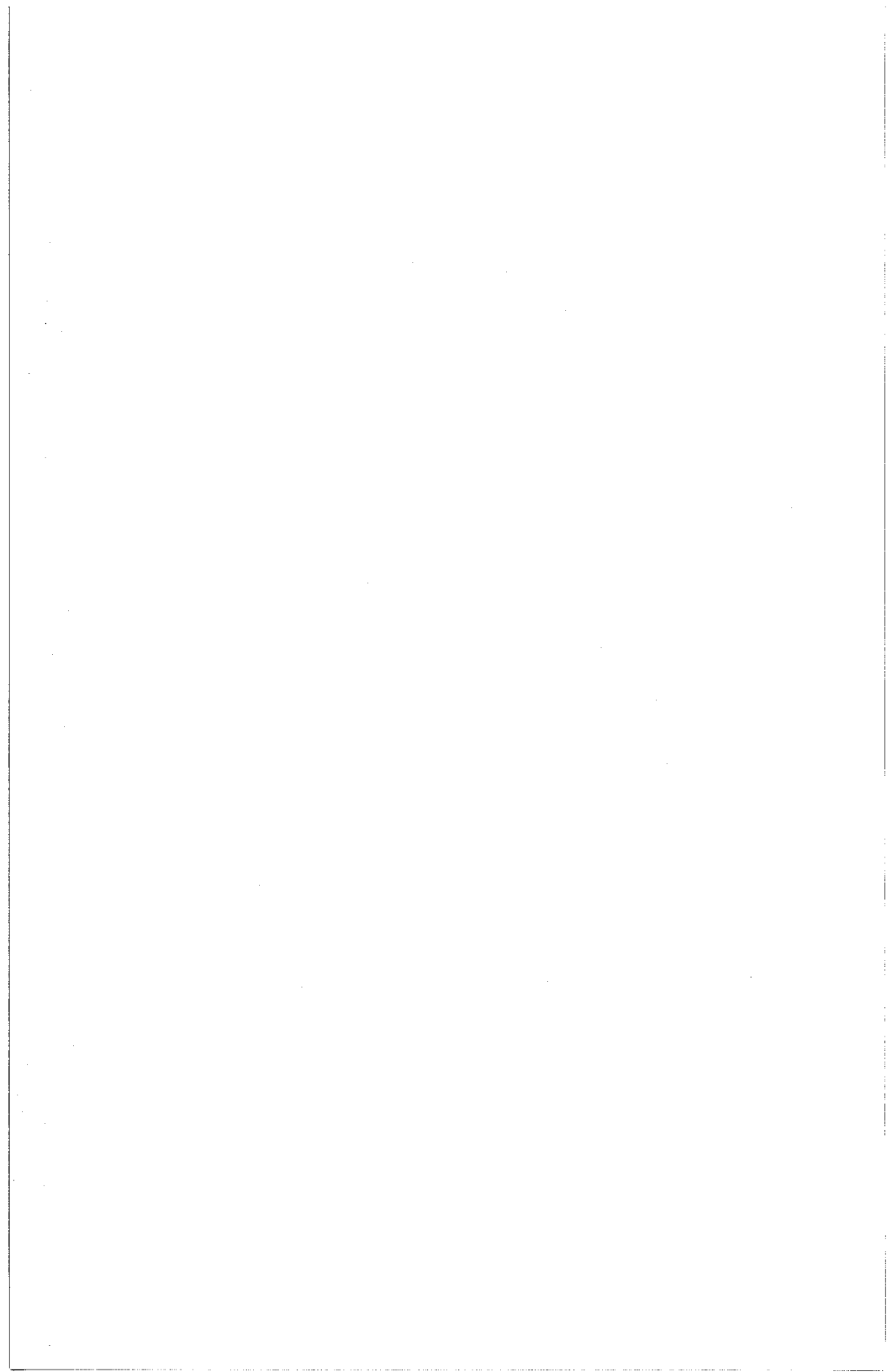

DETECTION OF BRANCH POINTS BY MODIFIED FFT

Fung I. Tseng and Tapan K. Sarkar
Department of Electrical Engineering
Rochester Institute of Technology
Rochester, New York 14623

Abstract

This paper illustrates the existence of branch points in transients on lossy transmission lines and presents a technique of detecting branch points. By applying modified FFT to the transient signal and from the resulting amplitude and phase spectra, it is possible to detect and distinguish branch points from poles. Numerous examples are given to demonstrate the effectiveness of the modified FFT and the use of windowing in improving the detectability of a small branch point under the influence of a nearby strong pole. (Ref: IEEE Trans on Geoscience and Remote Sensing, Vol. 21, Oct. 1983 pp 468-472.)

URSI/B-12-2

SOME COMMENTS ON EFFICIENT USE OF FFTS AND RELATED OPERATIONS IN SCATTERING AND DIFFRACTION CALCULATIONS

W. Ross Stone, IRT Corporation, 1446 Vista Claridad, La Jolla, CA 92037

Fast Fourier transforms (FFTs) and matrix operations are central to many efficient numerical techniques for electromagnetic scattering and diffraction calculations. The majority of computers used, at least in the development stages of such techniques, are machines designed to support multiple users. These machines usually also employ virtual memory systems. Discussions over the last few years with a number of creators and users of such computer programs have made it evident that many of them do not realize the very significant effects such an operating environment can have on the efficiency of these programs. This paper explains why this is so, and gives specific steps for avoiding these problems. Studies and examples are presented which were done using DEC VAX computers; however, the results apply to a variety of machines, including the larger Cray, Amdahl, IBM, and CDC Cyber series.

The concepts of virtual memory, paging, and their effects on disk interaction are briefly defined and explained. Examples from studies with the author's spatial frequency/time domain scattering programs are presented. It is shown that for matrix or FFT operations above a certain (and often surprisingly small) size, the operating system must spend substantial time paging memory onto and off of disk. This is true even though the total process (program plus data) size is small compared both to the core memory size of the machine and to the core available for a given user. In an extreme but not uncommon case it is shown that the operation of the FFT and the paging process can combine to increase the basic cycle time (multiply plus add) of the FFT by a factor of as much as 30,000. Optimizing an FFT for operating on disk-stored data usually does not avoid these problems, and can actually make them worse. Specific methods for avoiding these problems are given. Ways in which the FFT can be modified to optimize the process are explained, and it is pointed out which of several widely-used public domain FFT routines incorporate such capability, and which do not. It is shown how best to specify the operating environment for a program within the constraints usually readily available to each user on a multiuser system. Examples from studies with the author's spatial frequency/time domain scattering programs are used to illustrate these points, and it is demonstrated that dramatic improvements in computation time can be achieved simultaneously with a substantial decrease in the core memory required. For instance, it is possible to perform a disk-based 512 by 512 (262,144) point complex FFT on a VAX 11/780 in about 70 seconds, using only straightforward programs written in Fortran. How to achieve similar results for matrix operations of the kind often associated with electromagnetic computations is described. The fractional improvement to be expected versus programming cost of common optimization techniques is discussed.

Commission B

FAST CONVERGENT SOLUTIONS OF STRIP GRATINGS

Te-Kao Wu
Hughes Aircraft Company
Space and Communications Group
PO Box 92919
Los Angeles, California 90009

Strip gratings have been used extensively in the construction of polarizers, filters, artificial dielectrics and laser mirrors (T.K. Wu, AEU, April 1979 and R. Ulrich, Infrared Phys., 7, 37-55, 1976). The electromagnetic scattering from a strip grating has been studied using the moment methods with Fourier series as the current expansion functions (L.L. Tsai and J.T. Mayhan, IEEE T-AP, 24, 449-445, 1976). Recently, a new method incorporating the edge mode is shown to improve the convergence of the solution (J.H. Richmond, IEEE T-AP, 28, 883-887, 1980). However, only the TM scattering and free standing gratings are considered.

In this paper, the general scattering problem of strip gratings on a dielectric substrate is studied. The formulation is very similar to (J.P. Montgomery, IEEE T-AP, 23, 70-75, 1975). However, the efficient current expansion function incorporating the edge mode is considered. The numerical results checks with previously published data. It is interesting to note that previously more than 32 Fourier modes are needed to arrive at a convergent solution, while this method needs only two modes.

URSI/B-12-4

NUMERICAL REGULARIZATION AND THE SPECTRAL ITERATIVE TECHNIQUE

S. S. Chaiken
TRW
One Space Park
Redondo Beach, CA 90278

The Spectral Iterative Technique (S.I.T. cf. W. Ko and R. Mittra, IEEE Trans. AP-25, No. 2, 287-297, 1977) has been widely applied to the solution of integro-differential equations of the form

$$\int_{\Omega} A(r-r') f(r') dr' = g(r), \quad r \in \Omega \in \Omega_0$$

where f is of compact support on Ω , g defined by a unique and regular continuation throughout Ω_0 , and kernel A of questionable virtue, possibly singular but integrable in some generous sense, e.g. principal value. Since S.I.T. exploits a Fourier-product/spatial-convolution relationship, the question of numerical regularization of the transformed singular kernel \tilde{A} and finite truncation of the Fourier domain vis-a-vis the slowly decaying tails of \tilde{A} must be addressed. To this end, in an illustrative fashion we consider three applications of S.I.T. to one-dimensional equations of the above type whose solutions are known. Their respective kernels are continuous (of rational Fourier transform), weakly singular (Carleman kernel), and integrable only in Cauchy principal value. The cost and fidelity of solution is examined under various regularizations, truncations etc. Characteristics of the solution are displayed with an eye towards validation and extension. In the latter connection, the hazard of multidimensional Fourier regularization as pertains to the electromagnetic scattering of plates using a dyadic electric Green function is briefly considered. Computational results for simple, finite geometries are provided.

A COMPARISON BETWEEN THE SPECTRAL ITERATIVE METHOD (SIT) AND
THE CONJUGATE GRADIENT METHOD UTILIZING FFT

Tapan K. Sarkar
Department of Electrical Engineering
Rochester Institute of Technology
Rochester, New York 14623

Abstract

The spectral iterative method (SIT) has been widely used by Mittra et. al. They seem to present a picture that this method is well suited to analyze electromagnetic problems. They also seem to claim that the method converges quite fast for their initial guesses. Their initial guesses is often a first order approximation. The objective of this presentation is to show that the SIT does not minimize a meaningful error criterion at each iteration. Therefore there is absolutely no guarantee that the method will converge for all problems. In fact the SIT diverges even for the strip problem (for which Mittra et.al has presented extensive results). For example, even for a thin strip of $ka = 0.1$, SIT diverges (Vandenberg). In this presentation we introduce the conjugate gradient method to replace the semi convergent linear iterative method. The conjugate gradient method is a finite step iterative method unlike the other contemporary iterative techniques. Secondly, we utilize FFT in conjunction with the conjugate gradient method to solve the problem in the spectral domain. The advantage of solving the problem in spectral domain as first shown by Bojarski is that the complex convolution of the unknown with the Green's function becomes a simple multiplication in the transform domain. Also the advantage of the conjugate gradient method is that we solve a problem with approximately one-half the unknowns as solved by SIT. Therefore it comes as no surprise to us that the conjugate gradient method takes approximately one half the CPU time taken by SIT for the same initial guess and for the cases when SIT does work. Example will be presented to illustrate the above claims.

URSI/B-12-6

APPLICATION OF THE SPECTRAL-ITERATION APPROACH AND THE CONJUGATE GRADIENT METHOD TO THE PROBLEM OF SCATTERING BY STRIPS OF ARBITRARY WIDTH AND FOR E- OR H-WAVE INCIDENCE

W. L. Ko
University of Louisville
Louisville, Kentucky

R. Mittra
University of Illinois
Urbana, Illinois

The spectral iterative approach has been employed in the past to solve a wide class of scattering in a computationally efficient manner using the FFT algorithm. However, it has been found that in its original form the spectral iterative method does not always converge, although the built-in boundary condition test always reveals such non-convergence whenever it occurs. In this paper we combine the transform technique with the conjugate gradient algorithm to solve the problem of scattering from a strip of arbitrary width and for an arbitrary polarization of the incident field (E or H). In the spectral-iteration procedure, the generation of moment method type of matrix equation is bypassed completely and the evaluation of the convolution integral is carried out using the FFT algorithm; hence, the procedure is numerically efficient. In addition, an analytic form of the transformed Green's function is employed in the spectral domain approach. This function is easy to compute and does not require the evaluation of the Hankel functions as in the spatial domain. Furthermore, the procedure is readily extended to situations where the space-domain Green's function is difficult to express in closed form, e.g., for the case when the strip is placed on a dielectric slab. The conjugate gradient method provides an iteration scheme that is guaranteed to converge, and when combined with the spectral approach, provides a rather powerful as well as efficient scheme for solving the scattering problems of the type discussed in this paper. To illustrate the procedure we have chosen the problem of scattering by a strip of arbitrary width illuminated by a plane wave which may be either E or H-polarized. One of the important contributions of the paper is the numerical treatment of the partial differential operator appearing in the integral equation for the H-polarized case. Although Fourier-transforming this operator together with the Hankel function results in a simple algebraic expression for the Green's function, its asymptotic behavior for large α (transformation variable) is not very desirable for subsequent numerical manipulation. This difficulty can be totally overcome by replacing the partial derivatives by finite-difference operators and we have followed this procedure in the numerical handling of the integro-differential operator in the equation for the current on the strip. Extensive numerical results have been obtained for both the H-wave and E-wave incidences and are presented in the paper together with comparisons with moment method solutions. For the E-wave incidence, the current distribution possesses singularities at the edge of the strip. This behavior is correctly reproduced by the numerical solution, even with totally arbitrary initial guesses for the current distribution.

CONJUGATE GRADIENT SOLUTION OF ARBITRARY PLANAR
FREQUENCY SELECTIVE SURFACES

J. P. Montgomery and K. R. Davey
Georgia Institute of Technology
Engineering Experiment Station

Iterative methods offer tremendous potential to solve complex scattering problems because a matrix does not have to be stored or inverted explicitly. The spectral iteration technique has been applied to arbitrary two dimensional planar frequency selective surfaces (J. P. Montgomery, URSI Symposium Digest, p. 135, May 1983); however, convergence is not achieved in the most practical cases of interest where the periodic spacing is on the order of a half wavelength. This contrasts sharply with the one dimensional case of strips where convergence could be achieved in all cases by using variational multipliers based on either the current or the electric field. In order to overcome this convergence difficulty, the conjugate gradient method has been applied to the same general periodic structures. The particular form of the conjugate gradient method is based on an operator solution of the integral equation and has been recently described (Van den Burg, URSI Symposium Digest, pp. 97-100, August 1983). The iterative operations are implemented by using the DFT in the general two dimensional case. Integral equations with both the current or the aperture electric field as unknowns have been implemented. Furthermore, multiplanar structures of dissimilar surfaces have been solved. The periodic elements may be described by arbitrary polygons or by a point-by-point definition.

Convergence is always achieved with the conjugate gradient solution. Furthermore, the convergence is monotonic. The convergence properties are achieved as a result of using the original integral operator as well as the transpose conjugate in the iterative process which results in a positive definite system.

The solution has been applied to a variety of geometries including: (1) crossed dipoles, (2) the Jerusalem cross, (3) a meandering line polarizer, and (4) complex slot geometries. Both single and dual layer structures have been examined. These solutions and their convergence are presented and compared with other solutions including moment methods.

URSI/B-12-8

STUDY ON THE SCATTERING FIELD OF A RECTANGULAR DIELECTRIC SHELL WITH A PLANE WAVE INCIDENCE

Nai-hua Sun Han-kui Chen
(Microwave Research Laboratory, East China
Normal University, PRC)

Studies are made by the Method of Moments on the electromagnetic scattering field of a two-dimensional rectangular dielectric shell with a plane wave incidence. The incident wave considered is E_z polarized, and the scattered H field in particular is examined.

Special technique was used in the computation. In the partition of elements, the shell was first divided into lengthy rectangular ones which were further divided into smaller sub-elements aiming to save both the memory capacity and the computing time of the computer. The H field intensity was calculated from the derivative of the electric field intensity numerically.

The results of the study show:

1. The backward total H field intensity possesses the characteristics of a standing wave.
2. The H field, in total, inside the shell may be larger or smaller than that of the incident wave, and varies in an oscillating nature as the frequency changes.
3. In the vicinity of the shell, both inside and outside, the total H field intensity is elliptically polarized. The tilt angle and the axial ratio of the polarization ellipse depend on the dielectric parameters and the thickness of the shell, and also on the direction and the frequency of the incident wave.

The numerical results and the analytical results for the case of cylindrical shell were compared.

URSI COMMISSION B SESSION B-13
ELECTROMAGNETIC THEORY
Wednesday, June 27 1:30 - 5:00 P.M.
Room: ESSEX NORTH CENTER
Chairman: Yahya Rahmat-Samii
Jet Propulsion Laboratory, California
Institute of Technology, Pasadena, CA

1. AN OPEN SURFACE INTEGRAL FORMULATION FOR ELECTROMAGNETIC SCATTERING BY MATERIAL PLATES, E. H. Newman and M. R. Schrote, The Ohio State University ElectroScience Laboratory, Department of Electrical Engineering, Columbus, OH

2. A MIXED-FIELD INTEGRAL EQUATION FOR COMPOSITE BODIES, W. V. T. Rusch, Department of Electrical Engineering, University of Southern California, Los Angeles, CA, R. J. Porgorzelski, TRW Space and Technology Group, Redondo Beach, CA

3. A GENERALIZED DUAL SERIES APPROACH TO THE COUPLING OF AN E-POLARIZED PLANE WAVE TO A SLIT CYLINDER ENCLOSING A CONCENTRIC IMPEDANCE SURFACE, Richard W. Ziolkowski and J. Brian Grant, Lawrence Livermore National Laboratory, Electronics Engineering Department Livermore, CA

4. PLANE WAVE SCATTERING FROM AN OPEN SPHERICAL SHELL: A GENERALIZED DUAL SERIES APPROACH, Richard W. Ziolkowski, Electronics Engineering Department, Lawrence Livermore National Laboratory, Livermore, CA, William A. Johnson, Sandia National Laboratories, Albuquerque, NM

5. THE LIMITS OF PHYSICAL OPTICS FOR APPROXIMATING SCATTERED FIELDS, Hans-Jurgen Meckelburg, Ruhr-Universität, Bochum, W. Germany, Heinz Chaloupka, Bergische Universität, Wuppertal, W. Germany

6. THE DIFFRACTION OF WAVES BY A PENETRABLE PROLATE SPHEROID, R. Zimmer and R. Deleuil, Department de Radioelectricite, Universite de Provence, Marseille Cedex, France

7. COMPLEX EIGENFREQUENCIES OF AXISYMMETRIC OBJECTS: PHYSICAL INTERPRETATION IN TERMS OF RESONANCES, P. J. Moser, H. Uberall, B. L. Merchant, A. Nagl, and K. B. Yoo, Department of Physics, Catholic University, Washington, D.C., Samuel H. Brown, David W. Taylor Naval Ship R & D Center, Annapolis, MD, J. M. D'Archangelo, Department of Mathematics, U.S. Naval Academy, Annapolis, MD

8. WAVE PROPAGATION IN TWO-DIMENSIONALLY PERIODIC MEDIUM, S. T. Peng, Electromagnetics Laboratory, New York Institute of Technology, Old Westbury, NY, T. L. Dong, Microwave Research Institute, Polytechnic Institute of New York, Brooklyn, NY

9. ANALYSIS OF I.M.P. GENERATION FROM NON-LINEAR ANISOTROPIC STRATIFIED REFLECTORS, G. Ghione, M. Orefice, R. Zich, Dipartimento di Elettronica, Politecnico di Torino, Torino, Italy, D. Santilli, Selenia Spazio S.P.A., Roma, Italy

10. PHASE-SPACE ASYMPTOTIC ANALYSIS OF WAVE PROPAGATION IN HOMOGENEOUS DISPERSIVE AND DISSIPATIVE MEDIA, Ngo Dinh Hoc, Stanford University, Stanford, CA, Ioannis M. Besieris and Michael E. Sockell, Virginia Polytechnic Institute and State University, Blacksburg, VA

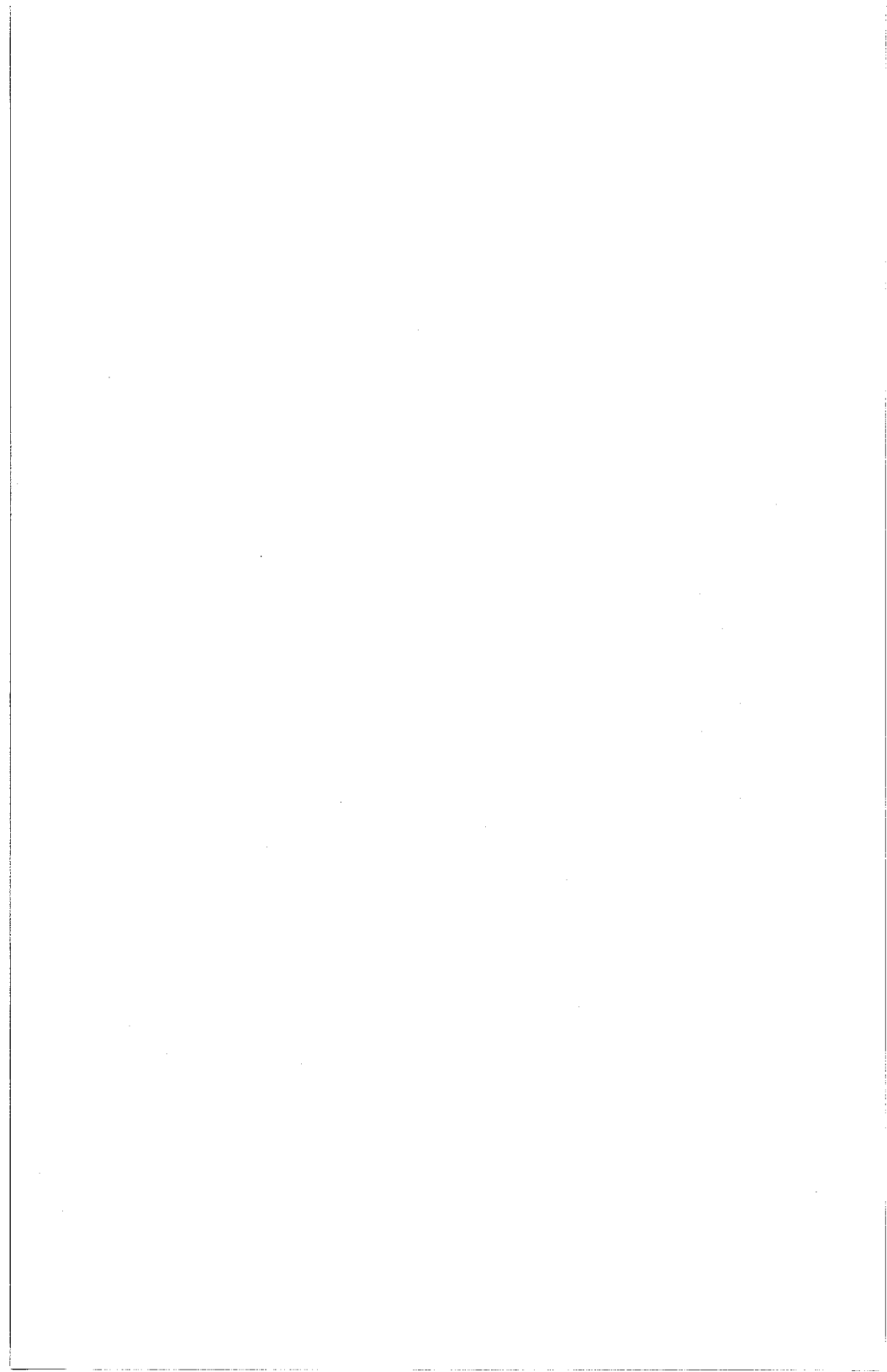

AN OPEN SURFACE INTEGRAL FORMULATION FOR
ELECTROMAGNETIC SCATTERING BY MATERIAL PLATES

E.H. Newman and M.R. Schrote
The Ohio State University ElectroScience Laboratory
Department of Electrical Engineering
Columbus, Ohio 43212

This paper will present an integral equation formulation and method of moments (MM) solution for the scattering by a thin material plate. By a material plate we mean a three dimensional planar slab of small but finite thickness, and composed of some dielectric and/or ferrite medium. Alternatively, it can mean a perfectly conducting plate coated on one or both sides by a thin dielectric/ferrite slab.

Currently MM computer codes are available which can model a perfectly conducting scatterer as an interconnection of perfectly conducting plates. The intended use of the material plate solution is as a first step to augment these codes so that they can treat interconnections of perfectly conducting and material plates. In formulating the material plate solution, the major criteria was that it should be able to be integrated into existing codes for perfectly conducting plates as easily as possible. For this reason, we formulated the material plate as a generalization of the perfectly conducting plate.

Basically, the solution for the material plate proceeds as follows. First, using the surface equivalence principle, one obtains four coupled integral equations for the equivalent electric and magnetic sum and difference currents on the surface of the plate. Next, two of these equations are approximated by surface impedance relationships. By including surface impedance terms which account for the coupling of currents on the top and bottom surfaces of the plate, one can treat both penetrable and impenetrable plates. This reduces the problem to two coupled integral equations which can be solved, via the MM, for the equivalent currents and then the scattered fields. Numerical results will be presented for scattering by penetrable and impenetrable plates.

This work was supported by the Dept. of the Navy,
Office of Naval Research, 800 North Quincy St.,
Arlington, Virginia 22217, under Contract No.
N00014-78-C-0049.

URSI/B-13-2

A MIXED-FIELD INTEGRAL EQUATION FOR COMPOSITE BODIES

W. V. T. Rusch
Department of Electrical Engineering
University of Southern California
Los Angeles, CA 90007

R. J. Porgorzelski
TRW Space and Technology Group
One Space Park
Redondo Beach, CA 90278

It is well known that the combined field integral equation:

$$-\alpha_H \hat{n} \times \vec{H}^{\text{scat}}(P) - \frac{1}{\eta} \alpha_E \hat{n} \times \vec{E}^{\text{scat}}(P) = \alpha_H \hat{n} \times \vec{H}^{\text{inc}}(P) + \alpha_E \hat{n} \times \vec{E}^{\text{inc}}(P)$$

for a point P just inside the surface of a radiating or scattering body provides a technique for obtaining the surface currents on the body while suppressing artifacts associated with possible resonances of the internal geometry. This paper describes a further extension of this approach (evolving out of preliminary informal discussions with D. R. Wilton of the University of Houston) which involves permitting the weighting parameters α_H and α_E to become functions of position on the body. For example, selection of α_H and α_E to be either 0 or 1 on various regions of the body effectively mixes the pure E-Field integral equation (EFIE), the pure H-field integral equation (HFIE), and the combined field integral equation (CFIE) in the same solution.

The mixed-field integral equation (MFIE) is advantageous when applied to numerous structures. For example: (a) wire radiators (requiring the EFIE) attached to large bodies (requiring CFIE) (J. F. Shaeffer and L. N. Medgyesi - Mitschang, IEEE Trans., AP-29, 479-487, May 1981); (b) flat wings (requiring the EFIE) attached to large air frames (requiring the CFIE) (K. J. Harker, National Radio Science Meeting, University of Houston, June 1983); (c) large structures (requiring CFIE) with a spatially varying impedance boundary condition (K. A. Iskander, L. Shafai, A. Frandsen, and J. E. Hansen, IEEE Trans., AP-30, 366-372, May 1982). In this last example, application of the EFIE in regions of variable impedance avoids having to specify the gradient of the impedance, which is required by the HFIE.

Results obtained using the MFIE are compared with canonical results for spheres and with integral-equation results for other structures.

A GENERALIZED DUAL SERIES APPROACH TO THE COUPLING OF AN
E-POLARIZED PLANE WAVE TO A SLIT CYLINDER ENCLOSING A
CONCENTRIC IMPEDANCE SURFACE*

Richard W. Ziolkowski and J. Brian Grant

Lawrence Livermore National Laboratory
Electronics Engineering Department
P. O. Box 5504, L-156, Livermore, CA 94550

The coupling of an electromagnetic wave through an aperture into an enclosed region is a fundamental problem from both theoretical and practical points of view. The newly developed generalized N-series approach [R. W. Ziolkowski, UCRL-88906, 1983 (to appear in SIAM J. Math. Anal.); W. A. Johnson and R. W. Ziolkowski, UCRL-88829, 1983 (to appear in Radio Science)] has made it possible to obtain analytic solutions to families of canonical problems descriptive of the electromagnetic coupling problem. In particular, it has led to the solution of the problem of an H-polarized plane wave scattering from an infinite circular cylinder with an infinite axial slot enclosing a concentric impedance surface [R. W. Ziolkowski, W. A. Johnson and K. F. Casey, UCRL-88169, 1983 (Proceedings, 1983 URSI Santiago Symposium)]. More recently, we have obtained the solution to the E-polarized plane wave version of this problem.

The generalized dual series solution of the E-polarized plane wave/slit cylinder problem will be reported. As in the H-polarized case, this solution accommodates arbitrary angles of incidence and cylinders and apertures that are small or large in wavelengths; and it encompasses the case of a slit cylinder enclosing a thin or thick concentric wire as well as an empty slit cylinder. Thus, field contours, currents on the cylinder, and axial currents along an interior wire can be studied as functions of wavelength for various aperture and wire sizes. Various examples of these investigations will be given. Moreover, comparisons of the E- and H-polarized results have indicated substantial differences between the coupling mechanism in both cases. Examples will also be given to illustrate these polarization dependent properties of the coupling process.

*This work was performed by the Lawrence Livermore National Laboratory under the auspices of the U.S. Department of Energy under contract W-7405-ENG-48.

URSI/B-13-4

PLANE WAVE SCATTERING FROM AN OPEN SPHERICAL SHELL: A GENERALIZED DUAL SERIES APPROACH*

Richard W. Ziolkowski, Electronics Engineering Department,
Lawrence Livermore National Laboratory, Livermore, CA 94550;
William A. Johnson, Division 7553,
Sandia National Laboratories, Albuquerque, NM 87185

The newly developed generalized dual series technique has been applied successfully to several two-dimensional electromagnetic coupling problems. [(W. A. Johnson and R. W. Ziolkowski, UCRL-88829, 1983 (to appear in Radio Science); R. W. Ziolkowski, W. A. Johnson, and K. F. Casey, UCRL-88169, 1983 (Proceedings, 1983 URSI Santiago Symposium)]. The resultant dual series solutions are being employed to study the coupling process as a function of wavelength, incidence angle, polarization, aperture size, scatterer size and interior loads. These results hopefully, will lead to general "engineering rules of thumb" which would enable one to estimate the coupling into more generally shaped cavities via more generally shaped apertures. However, the need to study and characterize any three-dimensional effects and to incorporate them in these "rules of thumb" is obvious.

The simplest three-dimensional generalization of the class of problems already considered is the scattering of a plane wave from a perfectly conducting spherical shell with a circular aperture. This problem encompasses an open spherical cavity and a spherical reflector. Hence, it is of great interest both theoretically and from a practical point of view.

The generalized dual series solution of the scattering of a plane wave with arbitrary polarization, angle of incidence and wavelength from an arbitrary open spherical shell will be presented. It will be shown analytically that the resultant fields and currents satisfy Meixner's edge conditions. Examples will be given that illustrate the dependencies of the current and field structures on the parameters of the open shell and the incident plane wave.

* This work was supported in part by Lawrence Livermore National Laboratory under the auspices of the U.S. D.O.E. under contract W-7405-ENG-48 and by Sandia National Laboratories.

THE LIMITS OF PHYSICAL OPTICS FOR APPROXIMATING
SCATTERED FIELDS

Hans-Jürgen Meckelburg, Ruhr-Universität, D 4630 Bochum, FRG
Heinz Chaloupka, Bergische Universität, D 5600 Wuppertal, FRG

There are a lot of analytical and numerical methods for calculating scattering by perfectly conducting three-dimensional bodies. A very simple approximation, considered in this paper, is the so-called physical optics, the validity of which however is strongly limited. Nevertheless an increasing interest in this method could be observed in literature recently. There are mainly two reasons:

- i) The solution of inverse scattering problems requires a simple relationship between geometry and scattering data. This is provided by physical optics.
- ii) Numerical methods, e.g. the method of moments, require a great deal of effort to calculate the scattered field from bodies, which are large in comparison to the wavelength and/or the geometry of which is very complicated. Hybrid methods are more convenient. They combine simple approximations, e.g. physical optics, with rigorous methods to minimize the numerical effort.

In this paper a new approximation, more powerful than physical optics, is introduced. It is derived from a "correction current" to physical optics and describes depolarization effects (H.-J. Meckelburg, Proc. URSI Symp. on Electromagnetic Theory, Santiago de Compostella, Spain, 119-122, 1983).

The new approximation is employed to investigate the usefulness of physical optics for the determination of monostatic and bistatic scattering by smooth convex, perfectly conducting bodies. The time domain representation of the physical optics solution permits a separation of high-frequency contributions stemming from the specular point and the shadow boundary. The shadow boundary portion is found to be erroneous. By means of an asymptotic $1/\omega$ -expansion of the scattering matrix the error of the physical optics contribution from the specular point is determined quantitatively. For the case of circular polarization physical optics leads to a rigorous solution for the first two orders of the $1/\omega$ -expansion of the copolar scattering.

THE DIFFRACTION OF WAVES BY A PENETRABLE PROLATE SPHEROID

R. ZIMMER and R. DELEUIL

Département de Radioélectricité, Université de Provence
Rue H. Poincaré, 13397 MARSEILLE CEDEX 13, FRANCE

The diffraction of an electromagnetic wave by a prolate spheroid with complex permittivity is analyzed by the method of separation of variables.

The electromagnetic field vectors are expanded in terms of radial and angular spheroidal functions R and S by means of the two functions M and N which derive from the scalar function Ψ solution of the scalar Helmholtz equation expressed in the spheroidal coordinate system (Stratton, Electromagnetic theory). The unknown coefficients of the expansion of the field vectors are determined by a system of linear equations derived from the boundary conditions.

So, an exact quasi-analytic solution for the both exterior and interior problems is obtained. The former was previously treated by Asano (Appl. Opt, 19, 712-723, 1979) and Schaefer (Ph. D. Thesis, Albany, N.-Y., 1980) for a dielectric spheroid and by Sinha & MacPhie (Radio Sci., 12, 171-184, 1977) and Dalmas and Deleuil (Optica Acta, 27, 637-649, 1980) for a conducting prolate spheroid; now, we re-find identical results for the situation already investigated. The latter was studied by us in some details and we took into account the effects of the main physical parameters, namely, the shape of the spheroid (specified by the a/b -ratio of the semimajor axis a to the semiminor axis b), the particle size (characterized by the quantity $2\pi a/\lambda$, where λ is the incident wavelength), the electromagnetic parameters of the medium (ϵ , σ and μ) and lastly the geometry of the scattering problem: the angle of incidence ζ (between the direction of incidence and the direction of the major axis) and the state of polarization (which can be resolved into two polarization components, the TE and TM modes, according as the magnetic or the electric vector lies in the plane of incidence).

We have calculated the values of the electric field at any point inside the spheroid and deduced the average specific absorption rate as a function of the a/b -ratio and for different values of the electrical conductivity σ . Our study shows that the internal field distribution is widely dependent on the shape of the lossy dielectric spheroid and on the frequency of the incident radiation. This allows us to conclude that we are able to generate *hot spots* in a lossy prolate spheroid when appropriate incident frequency is used. That is of interest, for example, in the field of biomedical applications.

COMPLEX EIGENFREQUENCIES OF AXISYMMETRIC OBJECTS:
PHYSICAL INTERPRETATION IN TERMS OF RESONANCES

P. J. Moser, H. Überall, B. L. Merchant, A. Nagl,
and K. B. Yoo
Department of Physics, Catholic University
Washington, DC 20064

Samuel H. Brown
David W. Taylor Naval Ship R&D Center
Annapolis, MD 21402

J. M. D'Archangelo
Department of Mathematics, U.S. Naval Academy
Annapolis, MD 21402

We calculate and compile complex eigenfrequencies of the electromagnetic vibrations of conducting spheroids and finite-length cylinders, and of the acoustic vibrations of soft and rigid spheroids. Eigenvibrations of non-longitudinal type have been studied by us earlier for the first time (P. J. Moser, Ph D dissertation, Catholic University, 1982; H. Überall et al, *Wave Motion* vol. 5, pp. 307-329, 1983). The present investigation has led to a physical explanation of the nature of non-longitudinal vibrations and their eigenfrequencies. For finite-length cylinders, helical surface waves will resonate (corresponding to a non-longitudinal eigenfrequency of the object) if certain phase-matching conditions are satisfied for both axial and azimuthal vibrations. This leads to a discrete manifold of possible helical surface waves, having well-defined pitch angles. The helical wave does not continue smoothly along the direction of the incident wave, but undergoes certain refraction effects (A. Nagl et al, *Wave Motion* vol. 5, pp. 235-247, 1983). A comparison between acoustic and electromagnetic eigenfrequencies of spheroids reveals significant differences, e.g. of acoustic attenuations increasing rapidly with target elongation in distinction to those of electromagnetic vibrations, indicating a fundamental difference in the mechanisms that govern the eigen-vibrations for the acoustic and electromagnetic cases.

URSI/B-13-8

WAVE PROPAGATION IN TWO-DIMENSIONALLY PERIODIC MEDIUM

S. T. Peng

Electromagnetics Laboratory
New York Institute of Technology
Old Westbury, NY 11568

and

T. L. Dông

Microwave Research Institute
Polytechnic Institute of New York
Brooklyn, NY 11201

We present here an exact formulation of the wave propagation in a canonical two-dimensionally periodic medium, whose dielectric constant varies sinusoidally in two orthogonal directions. The Floquet solution of such a canonical medium is generally represented by a double Fourier series and the harmonic amplitudes of the characteristic solution are governed by a scalar recurrence relation with double indices. We observe that such a recurrence relation may be recast into a three-term vector recurrence relation to which the technique of the generalized continued fractions can be applied. Thus, the dispersion relation and the harmonic amplitudes of the two-dimensionally periodic medium can be determined rigorously. Extensive numerical results have been obtained and are displayed in the form of dispersion curves for various parameters of the medium. The physical implications of the new dispersion characteristics will be discussed.

ANALYSIS OF I.M.P. GENERATION
FROM NON-LINEAR ANISOTROPIC STRATIFIED REFLECTORSG. Ghione, M. Orefice, R. Zich
Dipartimento di Elettronica, Politecnico di Torino
Corso Duca degli Abruzzi 24, TORINO (ITALY)D. Santilli
Selenia Spazio S.P.A.
Via Tiburtina km 12.4, ROMA (ITALY)

I.M.P. (Inter-Modulation Products) generation caused by non-linear behaviour of reflectors has to be considered today a significant source of trouble in the design of antenna systems where high power levels are involved. It is well known that I.M.P. generation may take place in metallic reflectors and components mainly because of the nonlinear effect of joints and weldings; the more recent introduction of carbon fibre reinforced plastics (CFRP) in reflector antennas has shown that bulk nonlinear phenomena, caused by the comparatively high level of intrinsic nonlinearity of graphite with respect to conventional materials, also play an important role in I.M.P. generation.

Electromagnetic wave propagation in a nonlinear environment has already been considered in the literature, but the assumptions made there on the nature of the medium do not apply to CFRP panels, which can be modeled as a layered anisotropic (biaxial) lossy nonlinear medium. In the present work an analysis is performed of such a medium, in order to evaluate the higher-harmonics fields backscattered by an air-panel interface when illuminated by several plane waves having different frequencies. Since only a small fraction of the incident power is converted into higher harmonics, a perturbative analysis of the non-linear interaction is possible. The linear field transmitted in the anisotropic layered medium at the different frequencies can be evaluated via standard transmission matrix techniques. These fields give rise to higher-harmonics fields and currents, and the backscattered field at the selected beat frequency can be computed by considering the transmission through the panel-air interface.

This technique allows to evaluate the equivalent currents flowing on the air-panel interface at the higher-harmonic frequency of interest; the possibility of relating these currents to the incident field through an anisotropic surface impedance is also investigated. As a final result, the power level of the intermodulation products caused by a given reflector can be evaluated.

URSI/B-13-10

PHASE-SPACE ASYMPTOTIC ANALYSIS OF WAVE PROPAGATION IN HOMOGENEOUS DISPERSIVE AND DISSIPATIVE MEDIA

Ngo Dinh Hoc

Stanford University

Stanford, California 94305

Ioannis M. Besieris and Michael E. Sockell

Virginia Polytechnic Institute and State University

Blacksburg, Virginia 24061

Arising naturally in the study of pulse propagation in homogeneous dispersive and/or dissipative media are certain classes of diffraction and/or diffusion integrals which encompass the canonical diffraction catastrophe integrals due originally to Thom. This is especially evident within the framework of a phase-space asymptotic analysis. Depending on the order of approximation of the exact solution beyond the "semiclassical" or "quasiparticle" limit, one recognizes caustic-like structures smoothed over by hyperdiffusion. Complete asymptotic series for these structures, which essentially define new basic functions, have been derived using the method of steepest descents, the WKB technique, the principle of dominant balance, and formal computer manipulations (e.g., the FORMAC73 language).

For illustrative purposes, specific analytical and numerical results will be presented for three types of canonical dispersive and dissipative media: cubic dispersive/quadratic dissipative, cubic dispersive/quartic dissipative, quintic dispersive/quartic dissipative.

URSI Commission B: Session on Basic Electromagnetic Theory or High Frequency Asymptotic Methods

URSI COMMISSION B SESSION B-14
NUMERICAL METHODS II
Thursday, June 28 8:30 A.M. - 12:00 NOON
Room: ESSEX NORTH WEST

Chairman: William A. Davis
Virginia Polytechnic Institute and State
University, Blacksburg, VA

1. A FLUSH MOUNTED COAXIAL WAVEGUIDE WITH A HEMISPHERICAL CENTER CONDUCTOR EXTENSION, Robert D. Nevels, Department of Electrical Engineering, Texas A&M University, College Station, TX

2. THE ERROR CRITERION FOR VARIATIONAL METHOD (Rayleigh-Ritz) GALERKIN'S METHOD AND THE METHOD OF LEAST SQUARES, Tapan K. Sarkar, Department of Electrical Engineering, Rochester Institute of Technology, Rochester, NY

3. PARTITIONING METHOD IN METHOD OF MOMENTS SCATTERING THEORY, K.J. Harker, SRI International, Menlo Park, CA

4. ELECTROMAGNETIC SCATTERING FROM AND COUPLING TO A THIN, PERFECTLY CONDUCTING SPHERICAL SHELL WITH A CIRCULAR HOLE: A COMPARISON OF TRIANGULAR PATCH MODELING AND A GENERALIZED DUAL SERIES TECHNIQUE, W. A. Johnson, Sandia National Laboratories, Electromagnetic Analysis Division, Albuquerque, NM, R. W. Ziolkowski, Lawrence Livermore National Laboratory, Electronics Engineering Department, Livermore, CA

5. METHODS OF MOMENTS FOR INTERCONNECTING PLATES IN ELECTROMAGNETIC WAVE SCATTERING PROBLEMS, J. F. Kiang and J. A. Kong, Department of Electrical Engineering and

Computer Science and Research Laboratory of Electronics, Massachusetts Institute of Technology, Cambridge, MA

6. ALTERNATIVE TREATMENTS OF A WIRE-SURFACE JUNCTION IN TRIANGULAR PATCH MODELING OF SURFACES OF ARBITRARY SHAPE, W. A. Johnson, Sandia National Laboratories, Albuquerque, N.M., D. R. Wilton, University of Houston, Houston, TX, J. B. Grant, Lawrence Livermore National Laboratory, Livermore, CA

7. ON THE CHOICE OF BASIS AND TESTING FUNCTIONS IN THE APPLICATION OF THE METHOD OF MOMENTS TO WIRE PROBLEMS, J. L. Fernandez Jambrina, and M. F. Catedra Perez, Departamento de Radiacion, Universidad Politecnica de Madrid, Ciudad Universitaria, Madrid, Spain

8. APPLICATION OF FINITE ELEMENT TECHNIQUE FOR THE COMPUTATION OF SCATTERING AND ABSORPTION CHARACTERISTICS OF ELECTROMAGNETIC WAVE DUE TO ARBITRARY SHAPED INHOMOGENEOUS BODIES OF REVOLUTION, A. Sreenivasan and S. C. Gupta, E & CE Department, University of Roorkee, India, R. K. Jain, Department of Electrical Engineering, Punjab Engineering College, Chandigarh, India

9. APPLICATION OF THE CLEAN TECHNIQUE TO MICROWAVE IMAGING, Jenho Tsao and Bernard D. Steinberg

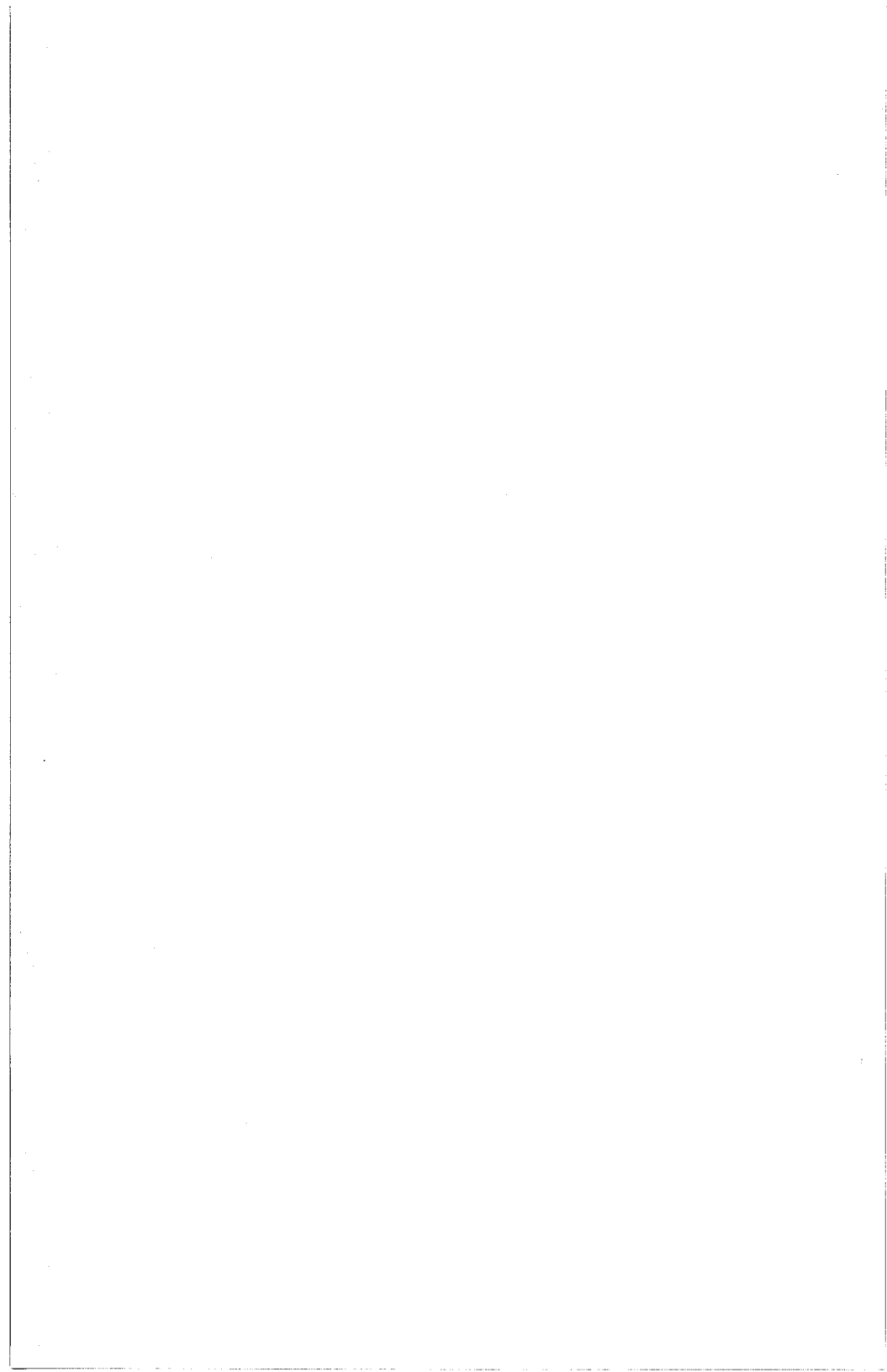

A FLUSH MOUNTED COAXIAL WAVEGUIDE WITH A
HEMISPHERICAL CENTER CONDUCTOR EXTENSION

Robert D. Nevels
Department of Electrical Engineering
Texas A&M University
College Station, Texas 77845

One method for determining the dielectric constant ϵ_d of a lossy medium is to use the measured and calculated reflection coefficient of an open ended coaxial waveguide which is placed against the unknown medium as shown in figure 1. However a configuration in which the coax is flush with the ground plane is useful over only a narrow frequency range mainly determined by the coaxial aperture dimensions. By extending the coaxial center conductor a short distance above the ground plane dielectric constant information can be obtained over an increased frequency range due to a significant change in input impedance properties of the coaxial line. On the other hand an extended center conductor presents a much more difficult analytical problem. Since near fields must be found a technique such as the method of Moments requires that one solve for three unknowns; the aperture field and currents on the side and end cap of the cylindrical center conductor extension.

In this paper an analysis of a coaxial line opening into a ground plane where the extended coaxial center conductor is a hemisphere (see figure 2) is presented. A configuration with a hemispherical center conductor extension has the advantages of a short cylindrical extension while the analytical work is simplified. A Green's function for a circular line source in the presence of a sphere can be readily found thereby reducing the problem of a hemispherical extension to one of solving for a single unknown - the aperture field.

The formulation of the integral equations and the numerical solution procedure are presented. Comparison is made between the input impedance of a flush mounted coaxial guide and one with a hemispherical extension. Also the biological heating property of these two types of radiators is compared.

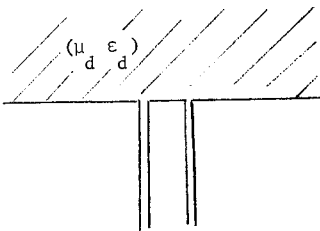

Figure 1

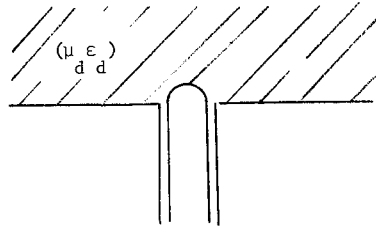

Figure 2

URSI/B-14-2

THE ERROR CRITERION FOR VARIATIONAL METHOD (Rayleigh-Ritz), GALERKIN'S METHOD AND THE METHOD OF LEAST SQUARES

Tapan K. Sarkar
Department of Electrical Engineering
Rochester Institute of Technology
Rochester, New York 14623

Abstract: Different mathematical techniques minimize different error criterions. However for certain problems some error criterion are more suitable than others. In this presentation we review the error criterion for the three well known techniques and apply the result to some canonical problems to investigate the conditions under which the methods become applicable. A tutorial paper on this subject is available (Sarkar, a Note on the Variational Method (Rayleigh-Ritz), Galerkin's method and the method of least squares. Radio Science, vol 18, pp. 1207-1224, Dec. 1983). In this presentation we looked into the applicability of these techniques to electromagnetic field problems and investigate the conditions under which they yield stable solutions. The important point to show that each of these technique has both advantages and disadvantages. So that there is no universally good method. This presentation points out the various advantages and the disadvantages of the three above mentioned techniques. Finally, the rates of convergence of the three techniques is presented.

PARTITIONING METHOD IN METHOD OF MOMENTS SCATTERING THEORY

K. J. Harker
SRI International
333 Ravenswood Avenue
Menlo Park, CA 94025

This paper discusses an improved method for predicting by the method of moments the electromagnetic scattering by a main body with a subsection, such as an appendage, which is varied either in position or shape. A straightforward method for accomplishing this task is to completely resolve the problem for each new position or shape of the subsection.

We describe a much faster method for solving the problem using the partitioning method (V. N. Faddeeva, "Computational Methods of Linear Algebra," Dover Publications, Inc., New York, 1959, p. 102). Using this method, we solve the scattering problem for the main body only once, while for each new position or shape of the subsection we only need to solve a scattering problem equivalent to that for the subsection. If the subsection is small compared to the main body, the computation time is greatly decreased.

Preference Commission B

URSI/B-14-4

ELECTROMAGNETIC SCATTERING FROM AND COUPLING TO A THIN, PERFECTLY CONDUCTING SPHERICAL SHELL WITH A CIRCULAR HOLE: A COMPARISON OF TRIANGULAR PATCH MODELING AND A GENERALIZED DUAL SERIES TECHNIQUE

W. A. Johnson*, and R. W. Ziolkowski**

* Sandia National Laboratories,
Electromagnetic Analysis Division, 7553
Albuquerque, New Mexico 87185

** Lawrence Livermore National Laboratory
Electronics Eng. Dept.
Livermore, CA 94550

Triangular patch modeling of surfaces combined with the Electric Field Integral Equation enables one to treat scattering from and coupling to surfaces of arbitrary shape (S.M. Rao, D. R. Wilton, A. W. Glisson, IEEE Trans. Ant. Propagat. AP-30-3, 409-418, 1982). In light of this development, it is desirable to obtain solutions for a class of canonical test problems so that comparisons with this patch code can be made. These test problems should possess both two-dimensional curvature and edges. Furthermore, both scattering and coupling problems are of interest.

Unfortunately, exact solutions to dynamic problems of this type are rare. The generalized dual series technique is analytic in nature and provides nearly an exact solution. The particular problem of a thin spherical shell with a circular hole has two-dimensional curvature, contains an edge at the aperture rim, and encompasses both the scattering problem of a spherical reflector and the exterior-interior coupling problem. Since the truncation in the dual series technique is not a truncation of the modal coefficients, the solution contains the correct edge singularities. This and other desirable features of this solution technique will be reviewed.

Comparison of patch code modeling and the dual series technique will be made for a variety of frequencies, angles of incidence, sphere radii, and hole sizes.

METHOD OF MOMENTS FOR INTERCONNECTING PLATES IN
ELECTROMAGNETIC WAVE SCATTERING PROBLEMS

J. F. Kiang and J. A. Kong
Department of Electrical Engineering and Computer Science
and Research Laboratory of Electronics
Massachusetts Institute of Technology
Cambridge, Massachusetts 02139

For electromagnetic wave scattering by large conducting bodies, the surface-patch model used in conjunction with the method of moments has been shown to alleviate problems such as the underestimation of induced currents and the damping constants in the corresponding wire-grid model. In the surface-patch model, various patch shapes and basis functions have been applied to simulate arbitrary body surfaces. However the important problem of interconnecting plates that are building blocks for more complicated conducting bodies has not been properly dealt with.

In this paper we extend the triangular-patch model and the radial current basis functions as developed by Rao, Wilton, and Glisson [IEEE Trans. Ant. & Prop., AP-30, 409-418, 1982] to study electromagnetic wave scattering problems involving interconnecting plates. We use overlapped patches along the interconnecting edge of two or more surfaces where the Kirchhoff current law is automatically satisfied. Computer simulations are tested. We calculate in particular the near-field and surface current distributions for the cases of multiply interconnected rectangular plates that are shown to reduce to the known results for bent rectangular plates in the limit. It is shown that rapidly varying surface current distributions occur as the multiply-interconnected plates are made too close to one another. The issues are resolved physically and mathematically by illustrating that the near field distributions are stable solutions for the varying surface currents.

URSI/B-14-6

ALTERNATIVE TREATMENTS OF A WIRE-SURFACE JUNCTION IN TRIANGULAR PATCH MODELING OF SURFACES OF ARBITRARY SHAPE

W. A. Johnson*, D. R. Wilton**, and J. B. Grant***

* Sandia National Laboratories, 7553
Albuquerque, N.M. 87185

** University of Houston
Houston, Texas 77004

*** Lawrence Livermore National Laboratory
Livermore, CA 94550

The Electric Field Integral Equation combined with triangular patch modeling of surfaces enables one to treat radiation and scattering from surfaces of arbitrary shape (S.M. Rao, D. R. Wilton, and A. W. Glisson, IEEE Trans. Ant. Propagat. AP-30-3, 409-418, 1982). Attachment of a thin wire to a triangulated surface has also been carried out.

In that treatment, the wire is attached to a vertex common to N surface patch triangles T_n . For each of these triangles a junction basis function is chosen so that the current runs radially along the surface, with a $1/\rho$ magnitude variation, into the junction vertex and then upward into the pigtail formed by the wire portion of the basis function. Care is taken to insure that no line charges are deposited on the triangular surface patches. Furthermore, these basis functions have been chosen so that in each T_n , the charge density has no radial variation and only a slight transverse variation. As the junction is moved towards an edge, an unphysical behavior of the current has been obtained due to a near linear dependence of the junction basis functions and the surface basis functions.

To rectify this problem the N junction basis functions are replaced by a single junction basis function. Any transverse variation in the surface currents not contained in the junction basis function are modeled with surface basis functions alone. In the choice of this new junction basis function, there are various choices of weightings for the amount of current that flows into each junction triangle. Each choice of weighting preserves the desirable features of the previous treatment. Furthermore, a minor modification of the basis function results in a constant charge density within each junction triangle and simplifies evaluation of the junction contributions to the impedance matrix. Comparison of results with those available in the open literature will be made.

ON THE CHOICE OF BASIS AND TESTING FUNCTIONS IN THE APPLICATION OF THE METHOD OF MOMENTS TO WIRE PROBLEMS.

J.L. Fernández Jambrina, M.F. Cátedra Pérez
Departamento de Radiación. Escuela Técnica Superior de Ingenieros de Telecomunicación. Universidad Politécnica de Madrid.
Ciudad Universitaria. Madrid -3-

In the application of moment methods to electromagnetic problems several sources of error appear. One of these is the truncation due to the use of a limited number of basis and testing functions. Another source is in the nature of these functions themselves. A theoretical study of these two sources of error has been undertaken by the authors. To test this study a special moment-method computer code has been developed for wire structures. Input to this code are the geometrical parameters and also the basis and testing functions. The code allows comparison of the effects of the choice of different sets of basis and testing functions, always using the same algorithms in the application of the method of moments. To do this, the wires are divided in overlapped subdomains. Each of these subdomains is also splitted in eight elements where the current and charge are made constant. Several results and conclusions for wire antennas and wire-modelled structures will be presented.

URSI/B-14-8

Application of Finite Element Technique for the Computation of Scattering and absorption characteristics of electromagnetic wave due to arbitrary shaped Inhomogeneous bodies of revolution

A. SREENIVASAN* Dr. S.C.GUPTA** Dr.R.K.JAIN***

Abstract

Finite element technique has been applied for the computation of scattering and absorption Complex amplitude coefficients for the time harmonic electromagnetic waves, from the arbitrary shaped bodies of revolution. Variational principles with two degree- freedom per node for axisymmetric case has been used in forming the elemental equations, and whose Euler's equation is the Helmholtz equation governing the wave propagation. Boundary conditions are applied in terms of spherical Harmonics. By summation technique, global matrices are formed. Solution routine incorporates Gaussian elimination with back substitution approach. Error minimization is done through least square surface fittings for the computation of scattering and absorption coefficients. The resulted complex amplitude coefficients are then readily used in determining scattering, absorption and estimation cross-sections. Test results for the sphere were compared with that of the analytical solution obtained by separation of variables. The computer programme (code) developed is general and applicable to any type of Higher order elements used in discretizing the finite element domain.

* Research Scholar (QIP), ECCE Department, University of Roorkee

** Professor, ECCE Department, University of Roorkee.

*** Professor, Dept. of Electrical Engineering, Punjab Engineering College, Chandigarh.

APPLICATION OF THE CLEAN TECHNIQUE TO MICROWAVE IMAGING

Jenho Tsao and Bernard D. Steinberg

An antenna array large enough to provide high angular resolution imaging at microwave wavelengths will be thinned by several orders of magnitude, for otherwise the cost would be excessive. It is evident that phased arrays large enough to provide the resolving power of these instruments will have a mean element spacing of thousands of wavelengths.

While such drastic thinning suitably limits the cost, it also insures an horrendous sidelobe problem. Huge sidelobes introduce artifacts into a microwave image. Grating lobes, resulting from periodicities within a thinned array, produce multiple repetitions of an image. Although grating lobes can be destroyed by randomizing the element positions, the high sidelobes of the random array introduces undesirable image artifacts.

A technique introduced nearly a decade ago in multiple element interferometry in radio astronomy is called the CLEAN technique. This paper extends the concept to the coherent radiation field due, for example, to target echoes from radar or sonar transmitters. The theory is put on a rigorous basis. A necessary condition is derived, which when satisfied ensures (with probability approaching unity) that all targets with intensities greater than certain thresholds will be detected and correctly located. The thresholds can be many decibels below the sidelobe level of the array, which is the purpose of the technique. The result is a considerable expansion of the target dynamic range that an imaging system can handle and a significant improvement in image contrast.

The threshold of target intensity at which detection is ensured is below the sidelobe level of the array by approximately twice the signal to noise power ratio. When the necessary condition is not satisfied (because the number of antenna elements in the array may be insufficient for the number of targets) it is not possible to ensure that all of the targets will be detected and correctly located at this low a level. The theory develops a second threshold for this case; this threshold, called the relative threshold, ensures (with probability close to unity) that the iterative procedure detects and locates the maximum possible number of targets and it stops the procedure before an image artifact is "discovered" to be a target. Thus, only true targets are reported and displayed.



**URSI COMMISSION 3 SESSION B-15
INVERSE SCATTERING AND IMAGING**
Thursday, June 28 8:0 A.M. - 12:00 NOON
Room: ESSEX NORTH EAST 
Chairman: W. Ross Stone 
IRT Corporation, La Jolla, CA

**1. MICROWAVE IMAGING BY HOLOGRA-
PHY AND TOMOGRAPHY: REVIEW AND
ASSESSMENT**, R. M. Bevenssee and R. J.
King, Lawrence Livermore Laboratory, Liver-
more, CA

**2. SYNTHETIC APERTURE IMAGING
OF THE EARTH FROM SYNCHRONOUS
ORBIT**, Alain C. Briancon and David H.
Staelin, Research Laboratory of Electron-
ics, Massachusetts Institute of Technology,
Cambridge, MA

**3. INVERSE SCATTERING FOR ONE-DI-
MENSIONAL DISPERSIONLESS DI-
ELECTRICS**, D. L. Jaggard and P. V.
Frangos, Moore School of Electrical Engi-
neering, University of Pennsylvania, Phila-
delphia, PA, K. E. Olson, Mitre Corpora-
tion, Bedford, MA

**4. TIME DOMAIN PROFILE INVERSION
OF A CYLINDRICALLY STRATIFIED
MEDIUM**, T. M. Habashy, Schlumberger-
Doll Research, Ridgefield, CT, R. Mittra,
University of Illinois, Urbana, IL.

**5. MICROWAVE HOLOGRAPHY OF
LARGE REFLECTOR ANTENNAS —
SIMULATION ALGORITHMS**, Y. Rahmat-
Sami, Jet Propulsion Laboratory, Califor-
nia Institute of Technology, Pasadena, CA

**6. EXTENSION OF SCALAR TO TEN-
SORIAL DIFFRACTION TOMOGRAPHY
FOR ANALYZING FARADAY ROTATION
EFFECTS**, Chau-Wing Yang, Brian James
and Wolfgang-M. Boerner, Electromag-
netic Imaging Division, University of Illinois
at Chicago, Chicago, IL

**7. USE OF A CONTINUATION METHOD
FOR THE EXTRACTION OF NATURAL
FREQUENCIES FROM A TARGET RE-
SPONSE: EXPERIMENTAL AND NU-
MERICAL RESULTS**, Edward Rothwell,
Department of Electrical Engineering,
Michigan State University, East Lansing,
MI, Byron Drachman, Department of
Mathematics, Michigan State University,
East Lansing, MI

**8. PROFILE INVERSION OF RADIAL
INHOMOGENEOUS MEDIA WITH
SINGLE FREQUENCY MEASUREMENTS**,
R. Mittra, University of Illinois, Urbana,
and T. M. Habashy, Schlumberger-
Doll Research, Ridgefield, CT

**9. RETRIEVAL OF APERTURE
FROM NEAR FIELD NOISY MEASUREMENTS**, Patrizia Basili and Pier-
partimento di Elettronica,
Roma "La Sapienza," Roma,



**MICROWAVE IMAGING BY HOLOGRAPHY AND TOMOGRAPHY:
REVIEW AND ASSESSMENT****R. M. BEVENSEE AND R. J. KING**

Various researchers have demonstrated the capability of microwave holography and tomography for resolving inhomogeneities from limited scattered or diffracted field data. Their analytic techniques for resolving the shapes of perfectly conducting bodies and of scalar dielectric distributions will be reviewed. These techniques will be evaluated for convenience in computer code implementation. Sampling theorems relating the distribution of measured vector field in real and frequency space to resolution of body shape, and dielectric distribution if pertinent, will be described.

URSI/B-15-2

SYNTHETIC APERTURE IMAGING OF THE EARTH FROM SYNCHRONOUS ORBIT

Alain C. Briancon and David H. Staelin
Research Laboratory of Electronics
Massachusetts Institute of Technology
Cambridge, Massachusetts 02139

Synthetic aperture techniques can be very usefully applied to remote sensing of the Earth from synchronous orbit where high spatial resolution is a controlling requirement. Here various design issues are discussed in the context of a radio spectrometer operating in the 118-GHz resonance band of oxygen so as to map the three-dimensional temperature structure of the atmosphere.

Two different system configurations were optimized and analyzed. For economic reasons these designs incorporate only one correlator for each frequency band. Each band typically would be 50-200 MHz wide and would be obtained simultaneously by filtering the outputs of two broadband i.f. amplifiers, one amplifier for each antenna. The preferred configuration incorporated a 35-cm diameter aperture at the end of and adjacent to a 35×300 cm strip reflector antenna mechanically scanned so as to produce a movable second 35-cm diameter aperture at spacings of 35-300 cm from the first. This structure would steadily rotate once every few minutes about an axis near nadir and centered on the image; this produces synthesized hexagonal images a few hundred kilometers in diameter. These images would be assembled to form a smooth mosaic covering the earth, one mosaic per frequency band.

The instrument baseline varied in triangle-wave fashion with 11 steps in baseline length, from zero to 3 meters. Per instrument revolution there were 47 triangle-wave periods. The sidelobes of the reconstructed beam pattern (defined as the synthesized pattern after division by the antenna gain pattern) were minimized by employing extensive multidimensional iterative Fletcher-Powell search schemes. Part of the success in this process resulted from placing much of the sidelobe energy where the primary pattern was weak, and outside the recovered hexagonal images. Thus the sidelobes were reduced without sacrificing spatial resolution. The 35-cm apertures were assumed to be uniformly illuminated in these calculations.

The 3-dB resolution of the system was 2.63 arc min, which corresponds to a diameter of 27.4 km at the equator (~ 34.3 km at 45° latitude), while the diameter of the area mapped was 264 km (~ 330 km at 45° latitude). The highest sidelobes of the synthesized on-axis beam were 22.9 dB inside the mapped hexagon, and 19.3 dB outside. If the rms sensitivity varies from 0.2 K to 0.4 K over each reconstructed hexagonal image, then to map a 6.4×10^5 km² region (e.g. 800×800 km) with a double-sideband receiver noise temperature of 800 K requires 160 sec and 620 sec for i.f. bandwidths of 200 and 50 MHz, respectively.

INVERSE SCATTERING FOR ONE-DIMENSIONAL DISPERSIONLESS DIELECTRICS

D.L. Jaggard[†], K.E. Olson^{*} and P.V. Frangos[†]
[†]Moore School of Electrical Engineering
 University of Pennsylvania
 Philadelphia, PA 19104
^{*}Mitre Corporation
 Burlington Road
 Bedford, MA 01730

Interest in inverse scattering and profile reconstruction has remained high since the initial work of Gel'fand, Levitan and Marchenko. This interest is due in part to the diverse applications of this method and in part to the exact nature of the Gel'fand-Levitan-Marchenko inversion. The major effort in the one-dimensional problem has been in the area of reconstructing the potential function $V(z)$ as a function of the coordinate z from knowledge of the reflection coefficient $r(k)$ for all wavenumbers k . This is equivalent to finding the *dispersive* refractive index $n(k, z)$ associated with the wave equation where

$$n(k, z) = 1 - V(z)/k^2 \tag{1}$$

Here we are interested in profile reconstruction for *dispersionless* dielectrics with refractive index

$$n(k, z) = n(z) \tag{2}$$

which is appropriate for many inverse problems in which the wavenumbers of the probing field are far away from material resonances.

We use as a starting point, the new integral equation recently given by Balanis [J. Math. Phys. 23, 2562-2568 (1982)]. We then apply the method of Kritikos, Jaggard and Ge [Proc. IEEE 70, 295-297 (1982)] to numerically solve this integral equation by leapfrogging in space and time, or we solve the integral equations analytically by use of Kay's differential operator technique [Research Report No. EM-74, New York University (1955)]. The numerical scheme is economical and avoids the inversion of matrices for complicated profiles while the analytic method provides insight into the solution of simple profiles.

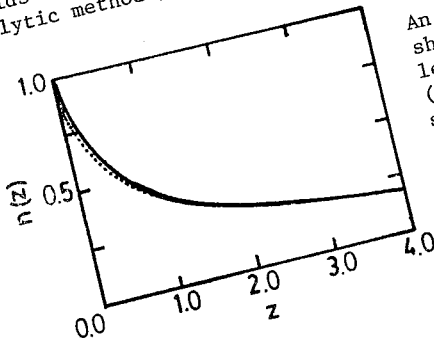

An example of these methods is shown in the figure on the left for the case $r(k) = 10.5 / (k + 10.5)$. The analytic inversion $n(z) = (1+3z)^{-2/3}$ ($z > 0$) is given by the solid line and the numerical inversion given by the dotted line.

Time Domain Profile Inversion of a Cylindrically Stratified Medium

T.M. Habashy and R. Mittra
Schlumberger-Doll Research
P.O. Box 307
Ridgefield, CT 06877

Although the problem of profile inversion in the time domain has been studied extensively in the literature, these studies have been typically restricted to planar profiles and for a plane wave type of illuminating source. In this paper we consider a cylindrically inhomogeneous medium which is illuminated by a dipole-type source.

Most of the presently available approaches that address the rigorous inversion problem, e.g., the methods of Marchenko and Gelfand-Levitan, do not offer convenient extension to the problem at hand and hence it becomes necessary to explore new methods for solving the inversion problem posed above. One such approach is described in this paper for both the TE and TM type excitations of a borehole type of geometry, typically found in geophysical exploration. Furthermore, most of the available techniques which utilize a single-frequency, variable transverse wavenumber type of illumination do not provide an obvious generalization to the time-domain case. However, a new frequency-domain inversion scheme for confined sources, which is described in a companion paper, lends itself to a convenient generalization to the time-domain inversion problem for cylindrical geometries.

Inversion procedures are given for both the TE and TM excitations when the medium is lossless and for the TE case illuminating a lossy medium. Additionally, the problem of inversion in the low frequency regime, where the conductivity of the medium plays a dominant role, is considered both for the TE and the TM polarizations and algorithms for inversion are presented.

We also show that, unlike the case of plane wave excitation, the measurement at a single receiver location does not provide sufficient information necessary to carry out the inversion in a unique manner. Finally, the new formulation is shown to lead to a generalization of the Marchenko algorithm for a lossless cylindrical profile illuminated by a confined time-domain source.

MICROWAVE HOLOGRAPHY OF LARGE REFLECTOR ANTENNAS
--SIMULATION ALGORITHMS

Y. Rahmat-Samii
Jet Propulsion Laboratory
California Institute of Technology
Pasadena, CA 91109

The performance of a large reflector antenna can be improved by identifying the location and amount of its surface distortions and then by correcting them. Microwave holography techniques are finding considerable applications as viable tools for performing this task. In these techniques, the complex (amplitude and phase) far-field pattern of the antenna is measured, using a reference antenna. Then, the Fourier transform relationship, which exists between the far field and a function related to the induced current, is invoked to result in the identification of the surface distortions. Recently, the use of an iterative procedure has also been considered to improve the final result [Y. Rahmat-Samii, 1983-URSI Symposium, Spain, 307-313, 1983].

To be able to critically examine the accuracy of the constructed surface profiles, simulation studies are required to represent the actual cases as realistically as possible by incorporating both the effects of systematic and random distortions. In particular, because most of the surfaces of large antennas are adjusted by properly setting surface panels, it is important to study the effects of the panels which are displaced. So far, most of the simulation models have been based on the aperture simulations which do not fully represent the actual curved reflector case.

In this paper, different simulation models are investigated with emphasis given to a model based on the vector diffraction analysis of the curved reflector with displaced panels. The effects of the displacement on the reflector far-field pattern are studied for different situations. These simulated far-field patterns are then used to reconstruct the location and amount of displacement of the surface panels by employing an FFT/iterative procedure. The sensitivity of the microwave holography technique based on the number of far-field sampled points, level of distortions, polarizations, illumination tapers, etc., is also examined. Most of the data are tailored to the dimensions of the NASA/JPL DSN (Deep Space Network) 64-meter reflector antennas.

URSI/B-15-6

EXTENSION OF SCALAR TO TENSORIAL DIFFRACTION TOMOGRAPHY FOR ANALYZING FARADAY ROTATION EFFECTS

Chau-Wing Yang, Brian James and Wolfgang-M. Boerner
Electromagnetic Imaging Division
Communications Laboratory/SEL 4210
Dept. of Electrical Engineering &
Computer Science/SEO 1141
University of Illinois at Chicago
851 S. Morgan St.
P.O. Box 4348
Chicago, IL 60680

The scalar theories of acoustic diffraction tomography have been developed for both backprojection and the back-propagation methods. Here, we extend it to the electromagnetic case taking the vector nature into account. First, the general formulation of the vector diffraction problem is considered in detail for strongly, as well as weakly discontinuous, inhomogeneous media. Whereas, for strongly inhomogeneous media at the present time it is not possible to formulate a solution, for the weakly discontinuous, inhomogeneous case for which Born and Rytov approximations apply, various methods of solution are proposed. Applying Jones transmission matrix calculus, the vector forward scattering properties of the discontinuities within each slice transverse to propagation direction are described by an effective transmission sub-matrix. The individual sub-matrices are then properly post-multiplied for each additional slice resulting in the total transmission matrix. To obtain a first order solution to the problem, the back-propagation and back-diffraction algorithms derived for the scalar case are then applied independently to the four components of the transmission matrix, where a linear H,V, polarization basis was introduced. First order corrections to this approach are suggested (B. James, M.Sc. Thesis, June 1984).

As a practical example, the modelling of the Faraday effect was considered to reconstruct the rotation angle and by utilizing standard relations of plasma dynamics it is shown how the inhomogeneous electron density profile and the index of refraction profile of an inhomogeneous media excited by an externally applied magnetic field parallel to wave propagation may be reconstructed (C-W. Yang, M.Sc. Thesis, January 1984).

URSI-F: Remote Sensing

USE OF A CONTINUATION METHOD FOR THE EXTRACTION
OF NATURAL FREQUENCIES FROM A TARGET RESPONSE:
EXPERIMENTAL AND NUMERICAL RESULTS

Edward Rothwell, Department of Electrical
Engineering ; and
Byron Drachman, Department of Mathematics
Michigan State University, East Lansing, MI, 48824

The continuation method used is a regularized L_2 -
homotopy method which minimizes the error between a
proposed fitting function (i.e., a finite term SEM
representation) and the measured response of a conduct-
ing body. Minimum error, with a penalty term acting as
a constraint, results in a set of natural frequencies
which best fit the measured target response in a well-
conditioned manner.

Various numerical results are presented which describe
the effects of noise, sampling density, choice of
number of modes, selection of final value of penalty
factor, and other factors on the extraction of
natural frequencies.

Also presented are results of the extraction of
natural frequencies from experimentally measured
responses. Measurements of both the backscattered
field and target surface currents are included.

Results show the inherent advantage of using this
continuation method over Prony's method, especially
in the presence of noise.

version of Radially Inhomogeneous Media with a Single
Frequency Measurement

R. Mittra and T.M. Habashy
 Schlumberger-Doll Research
 P.O. Box 307
 Ridgefield, CT 06877

Although the literature is replete with publications dealing with the problem of profile inversion of planar inhomogeneous media, few of these appear to have addressed the inversion problem in cylindrically inhomogeneous configurations, such as the borehole geometry typically encountered in geophysical explorations. Furthermore, many of the available techniques are limited in their application to lossless media, and for situations where no bound modes can be supported by the configuration. Finally, most of the inversion methods require the knowledge of the reflection coefficient $R(\gamma)$ as a function of the longitudinal wavenumber $\gamma (= \sqrt{k^2 - \beta^2}$ where β is the transverse wavenumber of the incident wave), over the entire range of γ on the real axis, whereas the physical measurements provide $R(\gamma)$ for $-\infty < \beta < \infty$.

In this paper we present a new integral equation for the wave function $v(\rho, \beta)$ which is associated with the transformed field $E_\phi(\rho, z)$ for the TE case or $H_\phi(\rho, z)$ for the TM case:

$$v(\rho, \beta) = v_0(\rho, \beta) + \int_{-\infty}^{\infty} d\xi P(\xi) M(\rho, \beta, \xi) v(\rho, \xi) \quad (1)$$

M is a known kernel expressible in terms of the incident wave v_0 , and $P(\xi)$ is as yet unknown. As a first step we solve for $P(\xi)$ by using v_0 in equation (1) and utilizing the fact that $v(a, \beta)$ is known from measurements. We next determine $v(\rho, \xi)$ for $\rho > a$ by repeatedly solving equation (1) with v_0 as the incident wave. Finally we obtain $q(\rho)$ from the kernel is now completely known.

$$\int_{-\infty}^{\infty} d\xi P(\xi) v_0(\rho, \xi) v(\rho, \xi)$$

E case
 $\omega^2 \mu \epsilon_c$

$$\epsilon_c + \frac{3}{4} \left(\frac{1}{\epsilon_c} \frac{\partial \epsilon_c}{\partial \rho} \right)^2 + \frac{1}{2\rho} \frac{1}{\epsilon_c} \frac{\partial \epsilon_c}{\partial \rho} - \frac{1}{2\epsilon_c} \frac{\partial^2 \epsilon_c}{\partial \rho^2}$$

ϵ_c and ϵ_s is the value of the complex permittivity of the source.

USE OF A CONTINUATION METHOD FOR THE EXTRACTION
OF NATURAL FREQUENCIES FROM A TARGET RESPONSE:
EXPERIMENTAL AND NUMERICAL RESULTS

Edward Rothwell, Department of Electrical
Engineering ; and

Byron Drachman, Department of Mathematics
Michigan State University, East Lansing, MI, 48824

The continuation method used is a regularized L_2 -homotopy method which minimizes the error between a proposed fitting function (i.e., a finite term SEM representation) and the measured response of a conducting body. Minimum error, with a penalty term acting as a constraint, results in a set of natural frequencies which best fit the measured target response in a well-conditioned manner.

Various numerical results are presented which describe the effects of noise, sampling density, choice of number of modes, selection of final value of penalty factor, and other factors on the extraction of natural frequencies.

Also presented are results of the extraction of natural frequencies from experimentally measured responses. Measurements of both the backscattered field and target surface currents are included.

Results show the inherent advantage of using this continuation method over Prony's method, especially in the presence of noise.

Profile Inversion of Radially Inhomogeneous Media with a Single Frequency Measurement

R. Mitra and T.M. Habashy
 Schlumberger-Doll Research
 P.O. Box 307
 Ridgefield, CT 06877

Although the literature is replete with publications dealing with the problem of profile inversion of planar inhomogeneous media, few of these appear to have addressed the inversion problem in cylindrically inhomogeneous configurations, such as the borehole geometry typically encountered in geophysical explorations. Furthermore, many of the available techniques are limited in their application to lossless media, and for situations where no bound modes can be supported by the configuration. Finally, most of the inversion methods require the knowledge of the reflection coefficient $R(\gamma)$ as a function of the longitudinal wavenumber $\gamma (= \sqrt{k^2 - \beta^2}$ where β is the transverse wavenumber of the incident wave), over the entire range of γ on the real axis, whereas the physical measurements provide $R(\gamma)$ for $-\infty < \beta < \infty$.

In this paper we present a new integral equation for the wave function $v(\rho, \beta)$ which is associated with the transformed field $E_\phi(\rho, z)$ for the TE case or $H_\phi(\rho, z)$ for the TM case:

$$v(\rho, \beta) = v_0(\rho, \beta) + \int_{-\infty}^{\infty} d\xi P(\xi) M(\rho, \beta, \xi) v(\rho, \xi) \tag{1}$$

where M is a known kernel expressible in terms of the incident wave function v_0 , and $P(\xi)$ is as yet unknown. As a first step we solve for $P(\xi)$ by setting $\rho = a$ in equation (1) and utilizing the fact that $v(a, \beta)$ is known from measurements. We next determine $v(\rho, \xi)$ for $\rho > a$ by repeatedly solving (1) whose kernel is now completely known. Finally we obtain $q(\rho)$ from the equation:

$$q(\rho) = 2 \frac{\partial}{\partial \rho} \int_{-\infty}^{\infty} d\xi P(\xi) v_0(\rho, \xi) v(\rho, \xi)$$

where for the TE case

$$q(\rho) = \omega^2 \mu \epsilon_s - \omega^2 \mu \epsilon_c$$

For the TM case

$$q(\rho) = \omega^2 \mu \epsilon_s - \omega^2 \mu \epsilon_c + \frac{3}{4} \left(\frac{1}{\epsilon_c} \frac{\partial \epsilon_c}{\partial \rho} \right)^2 + \frac{1}{2\rho} \frac{1}{\epsilon_c} \frac{\partial \epsilon_c}{\partial \rho} - \frac{1}{2\epsilon_c} \frac{\partial^2 \epsilon_c}{\partial \rho^2}$$

where $\epsilon_c = \epsilon(\rho) + i\sigma(\rho)/\omega$ and ϵ_s is the value of the complex permittivity of the medium at the position of the source.

RETRIEVAL OF APERTURE FIELDS FROM NEAR FIELD NOISY
MEASUREMENTS

Patrizia Basili and Piero Ciotti
Dipartimento di Elettronica, Università di Roma "La Sapienza"
Via Eudossiana 18, 00184 Roma, Italy

Very often the solution of several inverse electromagnetic problems, such as the identification of parameters of an electromagnetic structure, as well as the design of an electromagnetic structure with assigned performances, turn out to be difficult because of the ill-posed nature of the problem and the ill-conditioning of the involved kernels. Suitable inversion methods have to be used in order to overcome the difficulties related to the pathological sensitivity of the sought solution to approximations, measurement errors and computational noise.

In this paper the retrieval of the aperture field of an antenna is considered. The reconstruction of the source characteristics of a plane aperture from near field measurements, using the plane wave spectrum representation of the electromagnetic field, can be obtained through an integral equation, where the plane wave spectrum on the measurement plane represents the data and the field on the source plane is the unknown function. The Backward Fourier Transform (Hanfling, Borgiotti and Kaplan, IEEE AP-S Sympos. Digest, 764-767, 1979) of error-free measurements leads to an accurate reconstruction when the invisible part of the spectrum is included, but the solution is heavily corrupted by the presence of measurement errors, so that in this case the smoothed but stable version of the aperture field, obtainable using only the visible part of the spectrum is more significative.

After an analysis of the ill-conditioning associated with the pertinent kernels in order to determine the best trade-off between the achievable detail and the error amplification, the Kalman filtering has been used for reconstructing the source field by using different portions of the invisible part of the plane wave spectrum. A comparison between the Kalman filtering and the Backward Fourier Transform techniques has been carried out for various aperture illumination and error entities, with special attention to the accuracy of the fine details and the stability of the reconstruction. The analysis has pointed out the lower sensitivity to measurement errors of the Kalman filter and its effectiveness in giving stable solution with appreciable details.



**URSI COMMISSION F SESSION F-4
TROPOSPHERIC EFFECTS ON
PROPAGATION**

Thursday, June 28 8:30 A.M. - 12:00 NOON

Room: ST. GEORGE A, B

Chairman: Edward Altshuler

**Rome Air Development Center, Hanscom
AFB, MA**

1. DISPERSIVE EFFECTS OF THE ATMOSPHERE IN DIGITAL 10-30 GHz SATELLITE LINKS, W. A. Scales, D. M. Imrich, T. Pratt, W. L. Stutzman and C. W. Bostian, Satellite Communications Group, Virginia Polytechnic Institute and State University, Blacksburg, VA

2. A COMPARISON OF EARTH-ROTATION PARAMETERS AS DETERMINED BY THE GREEN BANK INTERFEROMETER WITH THOSE DETERMINED BY VLBI, Demetrios N. Matsakis and Frederick J. Josties, U. S. Naval Observatory, Washington, D.C.

3. GROUND MULTIPATH IN CIRCULARLY POLARIZED SATELLITE COMMUNICATION SYSTEMS, Vahraz Jamnejad, Jet Propulsion Laboratory, California Institute of Technology, Pasadena, CA

4. MEASURED FREQUENCY DIVERSITY IMPROVEMENT FOR DIGITAL RADIO, P. L. Dirner, AT&T-Bell Laboratories, West Long Branch, N.J., S. H. Lin, Central Services Organization, West Long Branch, N.J.

5. REFRACTIVE EFFECTS ON LONG LINE-OF-SIGHT PATHS, D. T. Hayes, U. H. W. Lammers and R. A. Marr, Rome Air Development Center, Hanscom AFB, MA

6. EFFECTS OF BOUNDARY LAYER PARAMETERS IN RADIOWAVE PROPAGATION MICROMETEOROLOGICAL CONTRIBUTION TO PACEM, C. Klapisz, J. Claverie, J. Lavergnat, M. Sylvain and A. Weill, CRPE Issy Les Moulineaux, France

7. EHF ATTENUATION DERIVED FROM EMISSION TEMPERATURES IN LIGHT RAIN, F. I. Shimabukuro, Electronics Research Laboratory, The Aerospace Corporation, El Segundo, CA

8. COMPARISON OF SKY TEMPERATURES MEASURED AT 42 GHz WITH DIFFERENT BEAMWIDTHS AND POLARIZATIONS, W. J. Vogel, Electrical Engineering Research Lab, The University of Texas, Austin, TX

9. MORE ON THE ABSORPTION OF MILLIMETER WAVES BY ATMOSPHERIC WATER VAPOR, D. C. Hogg, F. O. Guiraud and E. R. Westwater

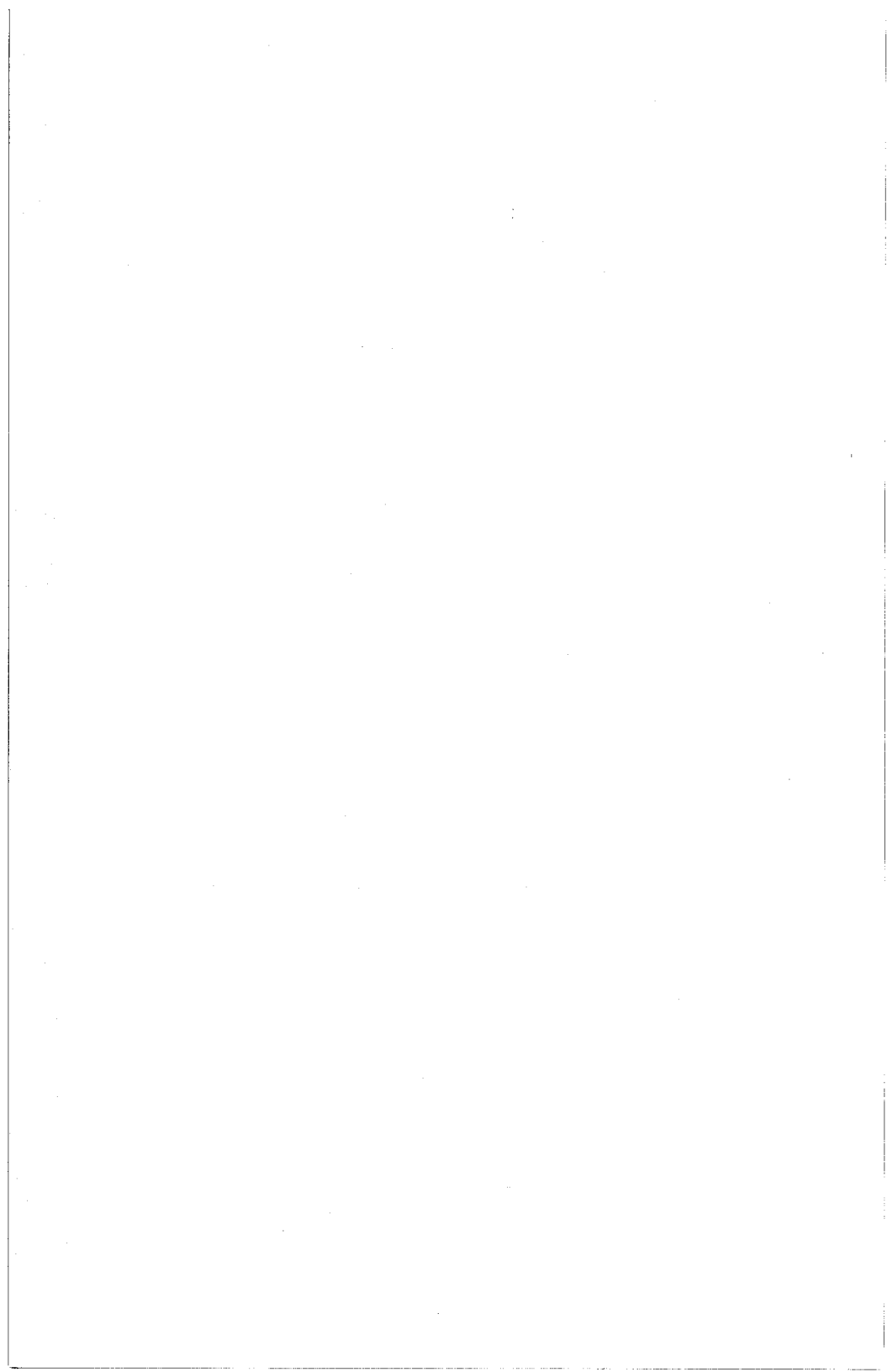

DISPERSIVE EFFECTS OF THE ATMOSPHERE IN
DIGITAL 10-30 GHZ SATELLITE LINKS

W. A. Scales, D. M. Imrich, T. Pratt
W. L. Stutzman and C. W. Bostian
Satellite Communications Group
Department of Electrical Engineering
Virginia Polytechnic Institute and State University
Blacksburg, Virginia 24061

This paper presents a method for combining the effects of atmospheric gases, raindrops, and ice crystals to calculate frequency-dependent attenuation, depolarization and phase delay variations across the bandwidth of a satellite path signal in the 10 to 30 GHz band. It uses these results to compute bit error rates for single and dual-polarized QPSK links at selected transmission rates. From these calculations, outage times at error rates as low as 10^{-8} are determined.

URSI/F-4-2

A COMPARISON OF EARTH-ROTATION PARAMETERS AS DETERMINED BY THE GREEN BANK INTERFEROMETER WITH THOSE DETERMINED BY VLBI

Demetrios N. Matsakis and Frederick J. Josties, U.S. Naval Observatory, Washington, D.C. 20390

We have re-reduced some of the Green Bank connected-element interferometer data using a new model atmosphere, where the atmospheric phase correction, in cm, for a given antenna is

$$2.27 * P * \text{secz} * (1 - \text{tanz}^2 * \text{cor}) + (3.776 * 10^4 / \text{Twet}^2 - 1.28 / \text{Twet}) * \text{Pwet} * \text{Wscale}$$

and P = total atmospheric pressure in mbar

secz = secant of the source zenith distance

tanz = tangent of the source zenith distance

$\text{cor} = \text{Dryscale} / \text{Rearth} + .000776 * P / 2 / \text{Tdry}$ (bending and refraction)

Dryscale = effective oxygen scale height = $.0265 * \text{Tdry} = R * T / (mG)$, km

Tdry = effective oxygen temperature = $T_{\text{surface}} - 20^{\circ}$, in Kelvin

Rearth = Earth radius, in km

Twet = effective water temperature = $T_{\text{surface}} - 10^{\circ}$, in Kelvin

Pwet = water pressure in mbar

Wscale = Scale height of water, in km

A numerical analysis comparing 9 days of our 1982 data with that determined from Polaris VLBI measurements shows that the new model reduces the Allan variance of the time-determination (UT1) by a factor of 3, to 1.2 millisecond, if Wscale is set to zero. A comparison of a much larger body of data, reduced in several different ways, will be presented.

In addition, improved editing and averaging algorithms will be noted, and their effects on the data accuracy estimated. Two water-vapor radiometers were installed in October, 1983 and their effectiveness will be discussed.

GROUND MULTIPATH IN CIRCULARLY POLARIZED
SATELLITE COMMUNICATION SYSTEMS

Vahraz Jamnejad
Jet Propulsion Laboratory
California Institute of Technology
Pasadena, California 91109

Recently more attention has been paid to the satellite-ground communication links in which the propagated wave is circularly polarized. This is particularly true in high UHF systems (such as land-mobile satellite system) where Faraday rotation could severely hamper or altogether prevent linearly-polarized operations. The multipath effects due to ground reflections in such circularly-polarized systems have not, however, been extensively studied. Here the coherent ground reflection problem is formulated directly in terms of the circularly-polarized wave components, and a rather interesting interpretation of the Brewster reflection angle is given in terms of circularly polarized waves. Thus at this particular angle a circularly polarized wave incident on an arbitrary ground plane (perfect or lossy) is transformed into a linearly polarized wave not necessarily parallel to the ground plane.

A theoretical upper bound is established for the ratio of the ground reflected interference to the directly received signal for generally imperfect transmit and receive antennas having cross-polarized components. A specific example is presented for a proposed future Ocean Topography Experiment (TOPEX) system.

URSI/F-4-4

Measured Frequency Diversity Improvement For Digital Radio

P. L. Dirner
AT&T-Bell Laboratories
West Long Branch, New Jersey 07764

S. H. Lin
Bell Communications Research
West Long Branch, New Jersey 07764

ABSTRACT

This paper presents the measured frequency diversity improvement factor for 6-GHz 16-QAM 90-MB/S digital radio on the 26.4-mile Atlanta-Palmetto path in Georgia. Two channels with a center frequency separation of 59.3 MHz were used in a one-by-one frequency diversity experiment. The 1980 data and the 1982 data indicate a frequency diversity improvement factor of 100 and 45 respectively at the outage threshold of 10^{-3} BER. This is in contrast to the improvement factor of 9 predicted for analog FM radio at the same fade margin. The measured one-by-one frequency diversity improvement factor is comparable to the measured space diversity improvement factor with 30-ft antenna spacing on the same path. We conclude that : (1) frequency diversity can provide a large improvement factor for digital radio, (2) as an alternative to space diversity, frequency diversity can provide substantial cost savings for digital radio routes, and (3) the frequency diversity calculation based on analog FM radio experience is too conservative (i.e., pessimistic) for digital radio application. These experimental findings are in agreement with recent advances in digital radio diversity modeling.

Digital radio performance depends heavily on the multipath dispersion in the channel. The measured data indicate that the power fade depths in the two channels are highly correlated whereas the multipath dispersion in the two channels is decorrelated. This correlation difference provides insight into the large difference in frequency diversity improvement factors for digital versus analog FM radio.

REFRACTIVE EFFECTS ON LONG LINE-OF-SIGHT PATHS

D. T. Hayes, U. H. W. Lammers, and R. A. Marr
Rome Air Development Center, Hanscom AFB, MA 01731

Atmospherically induced multipath propagation is considered a major factor in wideband LOS link availability. The problem is compounded on longer-than-conventional paths.

To study long range LOS propagation in the refractively perturbed atmosphere, two paths in New England (73km and 88km) were instrumented and operated during the fall ducting season of 1982 and 1983, respectively. Dual radio systems at 16 GHz were used to investigate both time of arrival differences and angles of arrival of multiple wavefronts under non-standard propagation conditions. A delay resolution of 2.5 nanoseconds or better was achieved with a 400 Mb/sec PRN modulation on one system. A vertically scanning 29-ft receiving antenna provided 0.15 degrees of resolution on the other system.

For a better understanding of the meteorological phenomena underlying the observed propagation effects, the Air Force Geophysics Laboratory conducted soundings aloft and on the ground at up to three locations along each radio path. Specific cases and overall results will be presented and interpreted on the basis of available radio and weather data.

URSI/F-4-6

EFFECTS OF BOUNDARY LAYER PARAMETERS IN RADIOWAVE PROPAGATION MICROMETEOROLOGICAL CONTRIBUTION TO PACEM

C. KLAPISZ, J. CLAVERIE, J. LAVERGNAT, M. SYLVAIN and A. WEILL
CRPE(CNET/CNRS), 92131 ISSY LES MOULINEAUX, FRANCE

The influence of boundary layer parameters on the terrestrial radiowave propagation appears in the relation between the air refractivity N and meteorological parameters (temperature T , pressure P and vapor pressure e). As T , P and e , N is height dependant and influences path propagation. Many of the propagational problems on line-of-sight links arise from the occurrence of anomalous departures in the vertical gradient from its normal value. Multipath propagation that can arise leads to selective fading, which is particularly prejudicial to high rate data communications.

It is of great interest to deduce from simultaneous radio and meteorological data situations of multipath propagation and to give a physical insight into the mechanisms leading to them.

The results presented here were collected during the PACEM experiment in June and July 1982 (SYLVAIN et al, Proc. URSI Commission F 1983 Symposium, Louvain, Belgium, June 1983). Anomalous changes in experimental refractive index profiles and their selective effects on propagation observed with a MLA (Microwave Link Analyser), have been detected. Ray-tracing techniques and simple theoretical considerations help to the understanding of these situations. Some specific examples and typical cases are studied here.

EHF ATTENUATION DERIVED FROM EMISSION
TEMPERATURES IN LIGHT RAIN

F. I. Shimabukuro
Electronics Research Laboratory
The Aerospace Corporation
El Segundo, California 90245 U.S.A.

Atmospheric emission measurements have routinely been used to determine the total attenuation on an earth-space path at the centimeter and millimeter wavelengths. In the presence of rain, scattering effects have to be taken into account at frequencies > 20 GHz when interpreting emission data to derive the total attenuation. If one uses the simple radiometric relation

$$\tau = \ln [T_o / (T_o - T_e)] \quad (1)$$

to determine the opacity for a measured emission temperature, T_e , one finds that, in rain, for accurate determinations of the opacity in all conditions over a large range of attenuations, the parameter T_o cannot be a constant, but is a function of frequency, rain rate, rain height, elevation angle, cloud cover, and ambient temperature.

Calculations of the atmospheric emission temperatures and attenuation at EHF in light to moderate rain are made, and the errors in the attenuation derived from emission measurements using (1) when the weather conditions and measurement geometry vary are investigated.

COMPARISON OF SKY TEMPERATURES
MEASURED AT 42 GHz WITH DIFFERENT
BEAMWIDTHS AND POLARIZATIONS

W. J. Vogel, Research Engineer
Electrical Engineering Research Lab
The University of Texas at Austin
10100 Burnet Road
Austin, TX 78758

The results of a one year measurement program of 42 GHz sky temperatures are presented. Since scattering at 42 GHz would tend to lead to an underestimation of attenuations derived from sky temperatures, an experiment was carried out to measure the sensitivity of the results to various experimental parameters. The data were collected with two antennas with 3.3° and $.2^\circ$ beamwidth. In addition, the polarization of the narrow beam antenna was switched between vertical and horizontal. Statistical and one-to-one comparisons of the data are made.

**MORE ON THE ABSORPTION OF MILLIMETER WAVES BY ATMOSPHERIC WATER
VAPOR**

by D. C. Hogg, F. O. Guiraud, and E. R. Westwater

An explanation of the absolute value of the electromagnetic continuum absorption by water vapor has been lacking for decades, and the theory is still in argument. However, measurements both in the laboratory and in the atmosphere are still ongoing. In this talk, measurements by millimeter wave radiometry and by radiosonde, taken at three locations in the U.S. where the total pressure is 1010, 920, and 840 mbar, are discussed. The magnitude of the dependence of the 31.65 GHz continuum absorption on total pressure is shown to be much stronger than conventional theory has indicated.



URSI COMMISSION B SESSION B-16



NUMERICAL METHODS III

Thursday, June 28 1:30 - 5:00 P.M.

Room: ESSEX NORTH WEST

Chairman: William A. Johnson

Sandia Laboratories, Albuquerque, N.M.

1. COMPUTATION OF Hz-SCATTERING FROM PENETRABLE CYLINDERS OF INFINITE LENGTH, Jamal S. Izadian, University of Santa Clara, Department of Electrical Engineering and Computer Science, Santa Clara, CA

2. TE SCATTERING FROM A CONDUCTING STRIP LOADED BY A DIELECTRIC CYLINDER, Maddumage D. G. Karunaratne and Krzysztof A. Michalski, Department of Electrical Engineering, University of Mississippi, University, MS, Chalmers M. Butler, Department of Electrical Engineering, University of Houston, Houston, TX

3. SCATTERING FROM A PERIODIC ARRAY OF CONDUCTING BARS HAVING FINITE RESISTIVITY, Barry J. Rubin, General Technology Division, IBM Corporation, Hopewell Jct, NY, Henry L. Bertoni, Department of Electrical Engineering and Computer Science, Polytechnic Institute of New York, Brooklyn, N.Y.

4. RADAR-CROSS-SECTION REDUCTION BY RESISTIVE EDGE LOADING, S Ray and R. Mittra, Electrical Engineering

Department and the Coordinated Science Laboratory, University of Illinois, Urbana, IL

5. E-FIELD, H-FIELD AND COMBINED FIELD SOLUTIONS FOR BODIES OF REVOLUTION WITH IMPEDANCE BOUNDARY CONDITIONS, A. A. Sebak and L. Shafai, Department of Electrical Engineering, University of Manitoba, Winnipeg, Manitoba, Canada

6. POLYNOMIAL PHASE INTEGRATION IN ONE AND TWO DIMENSIONS, R. J. Pogorzelski, TRW Space and Technology Group, Redondo Beach, CA

7. NUMERICAL FAR FIELD PREDICTION FOR DISTORTED REFLECTOR RADIATORS, T. J. F. Pavlasek, R. Pokuls, L. A. Wegrowicz, McGill University and Spar Aerospace Ltd., Montreal, Quebec, Canada

8. IMPLEMENTATION OF LINEARLY VARYING INTERVALS INTEGRATION ROUTINES FOR ANTENNA FIELD ANALYSIS, Alexander C. Brown, Jr., Goodyear Aerospace, Litchfield Park, Arizona

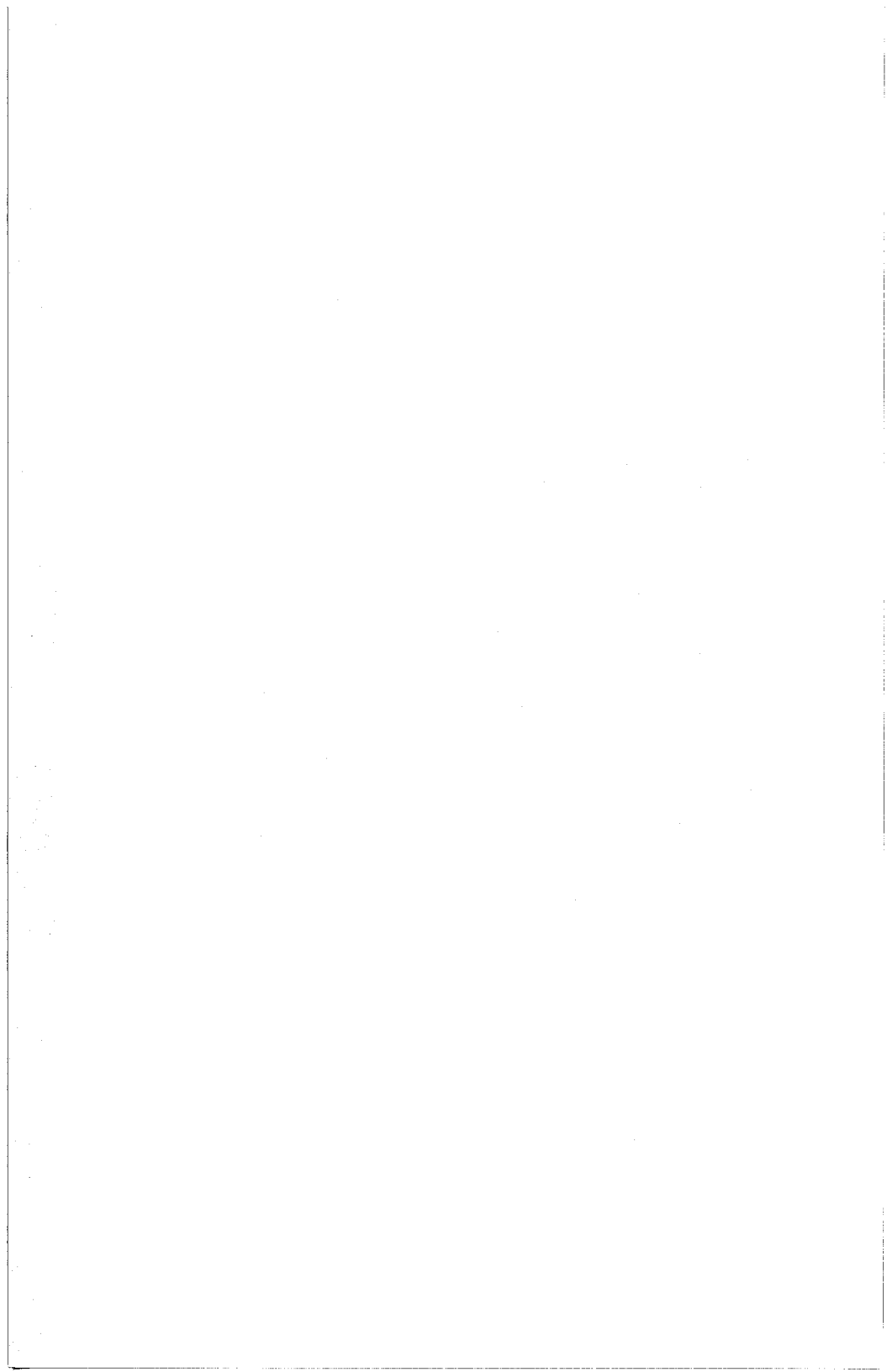

COMPUTATION OF Hz-SCATTERING FROM PENETRABLE CYLINDERS OF INFINITE LENGTH

Jamal S. Izadian

University of Santa Clara, Department
of Electrical Engineering and Computer Science
Santa Clara, CA 95050

The integral-equation formulation presented at the 1983 APS-URSI meeting dealt primarily with Ez-polarization. The Hz-polarization is more tedious because it involves some additional integrals. A scattering model is presented for calculating the scattered fields of a penetrable cylinder of infinite length when illuminated by fields of a parallel magnetic line source.

A Plane Wave Expansion Galerkin (J. Izadian, Ph.D. Thesis, The Ohio State University Department of Electrical Engineering, March 1983.) is used which results in more than an order of magnitude decrease in the computation time. This makes the computation for larger sized targets more feasible.

Additionally, the integral equation solution is extended to include a planar interface, which can be useful for situations involving a half space.

URS/B-16-2

TE SCATTERING FROM A CONDUCTING STRIP LOADED BY A DIELECTRIC CYLINDER

Maddumage D. G. Karunaratne
Krzysztof A. Michalski
Department of Electrical Engineering
University of Mississippi
University, MS 38677

Chalmers M. Butler
Department of Electrical Engineering
University of Houston
Houston, TX 77004

The problem considered is that of determining the induced current on and field scattered by a two dimensional, flat, perfectly conducting strip which is edge-loaded by a dielectric cylinder of circular cross section. The strip is placed radially with respect to the center of the cylinder and can be located outside, inside, or partially inside and partially outside the cylinder. The structure is excited by a plane wave polarized transverse electric to the cylinder axis. An integral equation is derived for the current density on the strip in the presence of the cylinder and is solved numerically by the method of moments. The kernel of the integral equation contains an infinite series of cylinder functions which converges slowly when both the source point and the field point approach the surface of the cylinder. A series acceleration method is employed to alleviate the convergence problem. Numerical results are presented which illustrate how the current, the scattered field, and radar cross section are affected by the presence of the dielectric cylinder.

SCATTERING FROM A PERIODIC ARRAY OF CONDUCTING BARS
HAVING FINITE RESISTIVITY

Barry J. Rubin, General Technology Division of the IBM Corp., Hopewell Jct., N.Y. 12533 and Henry L. Bertoni, Department of Electrical Engineering and Computer Science, Polytechnic Institute of N.Y., Brooklyn, N.Y. 11201.

A new method is presented for calculating the reflection coefficient and current distribution when a plane wave is incident on a periodic array of infinite, conducting hollow bars (Fig. 1) in a homogeneous dielectric. The conductors may have finite sheet resistance, the cross-section need not be rectangular, and the wave has TM polarization.

The surface current density is approximated as a linear combination of x- and z- directed triangular functions, with continuity of current enforced around corners. A matrix equation whose solution is the current density is obtained by finding the electric field in terms of the current coefficients, and then applying the electric field boundary condition in an integral sense along line segments of the conductor perimeter. The matrix, with order equal to the number of current coefficients, has elements which are rapidly converging infinite series. Since the current within the unit cell is subsectional, any conductor shape consisting of x- and z- directed steps may be accommodated.

Numerical results are presented for a number of structures having various values of bar width w , thickness t , and spacing d , and are compared with results, where available, reported in the literature. The use of such arrays for polarizers, transmission gratings, and shields is discussed. The convergence of the matrix elements and the number of current elements required for accurate results are investigated.

One structure of interest consists of parallel fins ($w=0$, $t=\lambda$, $d=0.75\lambda$). For perfect conductors, excellent agreement is shown with results obtained from a modified residue calculus technique (J. P. Montgomery, IEEE Trans. AP-27, 798-807, 1979). A finite sheet resistance ($5\Omega/\text{sq.}$) is then included and is shown to decrease the magnitude of the reflection coefficient at all angles of incidence, cause a negative phase shift especially large around the angle of resonance, but not significantly shift this angle.

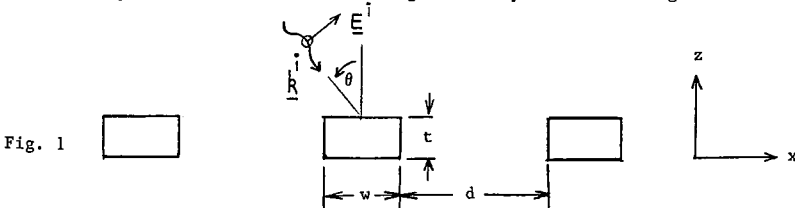

Fig. 1

URSI/B-16-4

RADAR-CROSS-SECTION REDUCTION BY RESISTIVE EDGE LOADING

S. Ray and R. Mittra
Electrical Engineering Department
and the
Coordinated Science Laboratory
University of Illinois
Urbana, IL

Edge diffraction is a significant contributor to the scattered electromagnetic field from a complex metallic body. The local nature of edge diffraction suggests that elimination or modification of edges may result in a significant reduction in the radar-cross-section (rcs) of the scatterer. Such modifications include construction of the edges with non-metallic materials and coating with appropriate radar absorbers. Many of these materials may be characterized by a surface resistance or impedance. Such a description is useful in scattering calculations over a wide range of frequencies and incident field angles.

In this paper we analyze scattering from metallic strips and plates with resistive edge loading. The center region of the scatterer is metallic with one or more edges consisting of a resistive material. The value of the surface resistance near the edges is allowed to vary as a function of position. The effects of various types of edge loading on the induced current and scattered field is studied. Comparisons are made with perfectly conducting scatterers and with scatterers with constant, large surface resistances. A graded resistance, with R varying from zero at the metal boundary to R_{\max} at the edge is seen to work well. In the case of a strip with E-wave illumination, a graded resistive edge load on the leading edge reduces the rcs significantly. For grazing and near grazing incidence, the strip behaves nearly like a strip with constant $R=R_{\max}$.

Numerical solutions are obtained by an E-field integral equation technique. The method of conjugate gradients (Van den Berg, 1983, URSI Symposium on Electromagnetic Theory, Santiago de Compostela, Spain) is used to solve the integral equation. This iterative technique minimizes the integrated square error of the integral equation in solving for the induced current. The method does not require matrix inversion or storage and is mathematically guaranteed to converge. Convergence of the algorithm is monotonic and fairly rapid for most cases. By combining the conjugate gradient technique with spectral domain methods of calculating convolutions via the FFT algorithm, a numerically efficient solution is obtained.

E-FIELD, H-FIELD AND COMBINED FIELD SOLUTIONS FOR BODIES OF REVOLUTION WITH IMPEDENCE BOUNDARY CONDITIONS

A.A. Sebak and L. Shafai
Department of Electrical Engineering
University of Manitoba, Winnipeg
Manitoba, Canada R3T 2N2

Numerical solution of an electric field integral equation for bodies of revolution with impedance boundary conditions was carried out by Iskander et al. (IEEE, Trans., AP-30, 366-372, 1982). Similar to the perfectly conducting objects, such a formulation suffers from the internal resonance effects, even though its integral operator involves both EFIE and MFIE operators. To study the problem in detail, the magnetic field integral equation is also formulated, which is used together with the electric field integral equation to generate a combined field integral equation. For the incident field, a plane wave with an arbitrary direction of incidence and polarization is assumed.

The above three formulations are used to study both internal resonance effect and the stability of the numerical solutions. The computed surface currents and the radiated far fields are compared and the dependence of their accuracy on the generating curve modeling, the object geometry and the material composition are determined. The details of the results will be presented during the presentation.

URSI/B-16-6

POLYNOMIAL PHASE INTEGRATION IN ONE AND TWO DIMENSIONS

R. J. Pogorzelski
TRW Space and Technology Group
One Space Park
Redondo Beach, CA 90278

In several earlier works this author has introduced an integration algorithm applicable to one dimensional complex integrals wherein the phase of the integrand may be accurately approximated by a quadratic. (R. J. Pogorzelski, IEEE/AP-S International Symposium, Los Angeles, June 1981) (R. J. Pogorzelski, IEEE Trans., AP-31, 748-755, Sept. 1983) (R. J. Pogorzelski, National Radio Science Meeting, Boulder, Jan. 1984). In essence the integral is reduced via the fast Fourier transform to a sum of integrals which may be very accurately and efficiently generated recursively. The present work concerns three generalizations of this type of algorithm.

First, it is pointed out that the degree of the polynomial with which one approximates the phase need not be limited to two. In fact, the derivation of a recursive formula suitable for phase approximating polynomials of arbitrary degree is exhibited.

The second generalization concerns two dimensional phase integrals. It is shown that much of the reasoning applied in the one dimensional case may be carried over to two dimensions resulting in a useful generalization of the familiar Ludwig algorithm. (A. C. Ludwig, IEEE Trans., AP-16, 767-769, Nov. 1968). It must be admitted, however, that at its present stage of development the accuracy and/or efficiency of this two dimensional generalization of the algorithm is not quite as impressive as in the one dimensional case.

Thirdly, it is noted that in both the one and two dimensional cases, the coefficients of the phase approximating polynomial need not be purely real. Allowing them to be complex results in algorithms capable of handling integrands of general complex exponential type considerably broadening the utility of this approach with essentially no additional effort.

NUMERICAL FAR FIELD PREDICTION
FOR DISTORTED REFLECTOR RADIATORS

Pavlašek, T.J.F., Pokuls, R., Wegrowicz, L.A.
McGill University and Spar Aerospace Ltd.
Montreal, Quebec, Canada

1. Numerical realization of the analysis of non-ideal surface, reflector antennas with distortions is discussed and results are compared with measured data. The comparison shows a high degree of agreement, demonstrating the effectiveness of the technique for studying and predicting the behaviour of such radiating structures including non-confocally fed configurations.

2. A hybrid numerical procedure has been developed for the calculation of far field patterns, based on the aperture integration method supplemented by the GTD technique, taking into account arbitrarily distorted surfaces, non-confocal feed locations as well as various aperture shapes with blockage or for off-set feeds. The surface is presumed to be known analytically or as a set of measured points; the feed illumination is also known analytically or from measurements. Characterization of the surface from the set of measured data is achieved by interpolation procedures to find local, analytical expressions for it, using Taylor Series expansion or least square fit techniques.

An efficient aperture integration method requires the knowledge of the field at prescribed locations in the aperture, and a minimization procedure using a steepest descent technique based on the Fermat principle is therefore used for ray tracing to determine the points of reflection on the distorted surface. Special attention is given to the non-unique ray tracing and other limitations which are thus imposed on the degree of distortion, that can be managed by the method.

3. Results are presented for a number of structures whose actual surfaces were measured at a set of points and whose far field patterns were also measured. The feed illumination was also determined experimentally. The surface shape data and the illuminating feed data were used as the input for the far field calculations. Calculations were also made for corresponding 'ideal' paraboloidal reflectors.

The results of the calculations for the distorted cases show good agreement with the measurements. These calculations can be used reliably to predict the behaviour of distorted reflecting radiators, and can thus be used as a means of investigating the effects on the radiation due to various factors and can thus be directed towards the design of such systems.

IMPLEMENTATION OF LINEARLY VARYING INTERVALS INTEGRATION ROUTINES FOR ANTENNA FIELD ANALYSIS

Alexander C. Brown, Jr.
Goodyear Aerospace, Arizona Division
Litchfield Park, Arizona 85340-0085

Recently, a reduction of computer run times of up to a factor of three (3) has been demonstrated for single dimensional integrals by A. C. Brown, Jr. (USNC/URSI Meeting, University of Houston, p. 56, May 1983) using Newton-Cotes formulas (specifically Simpson's) with linearly varying intervals instead of equal length intervals. Now, a reduction of computer run times by a factor of 12.5 has been achieved for near field computation by the aperture field method. This computation involved the evaluation of a two dimensional integral using Simpson's rule with linearly varying intervals. Some reduction factors of from 3 to 5 have been obtained for the far field computation of various reflectors using the induced current method.

This paper describes how to implement an integration routine with linearly varying intervals into codes written to compute fields by both the aperture field and the induced current methods. Specifically, a special algorithm is described which uses desired integrand sampling rates to compute the parameters needed to implement a linearly varying interval length integration routine. For instance, the user specifies how frequently an integrating algorithm (e. g. trapezoidal or Simpson's rule) ought to be applied per cyclic variation of the integrand with respect to the variable of integration and/or a given integrand magnitude. Using this information and computed integrand frequencies and magnitudes at appropriate limits of integration, the special algorithm computes: 1) the rate of interval length change, 2) the total number of intervals, 3) the adjusted initial interval length and 4) the adjusted final interval length. These four quantities are sufficient to operate a composite integration routine with linearly varying intervals.

Finally, both truncation and roundoff errors are considered for representative integrands. On the basis of this information, integrand sampling rates can be specified by the user to achieve desired levels of accuracy.

**URSI COMMISSION A SESSION A-I
MEASUREMENTS FOR ANTENNAS**

Thursday, June 28 1:30 - 5:00 P.M.

 **Room: ESSEX NORTH EAST** 

**Chairman: Harry Cronson
MITRE Corporation, Bedford, MA**

1. SPHERICAL SURFACE SAMPLING, Edward B. Joy and James B. Rowland, Jr., School of Electrical Engineering, Georgia Institute of Technology, Atlanta, GA

2. EVALUATION OF MICROWAVE ANECHOIC CHAMBER MEASUREMENT, Motohisa Kanda and R. David Orr, National Bureau of Standards, Electromagnetic Fields Division, Boulder, CO

3. A MODULAR TESTBED DESIGN OF A HIGH RESOLUTION POLARIZATION RADAR FOR TARGET IN CLUTTER DETECTION AND DESCRIPTION, Robert M. Lempkowski and Wolfgang-M. Boerner, Electromagnetic Imaging Division, Communications Laboratory, Dept. of EE & CS, University of Illinois of Chicago, Chicago, IL

4. AN INTEGRATED WR22 RESOLVER STYLE 6-PORT FOR MAKING ACCURATE REFLECTION COEFFICIENT MEASUREMENTS OVER THE BAND 33-50 GHz, Gordon P. Riblet, Microwave Development Laboratories, Natick, MA

5. MODIFICATION OF THE SPECTRAL DENSITY OF THE THERMAL NOISE WITHIN A MICROWAVE CAVITY EQUIPPED WITH AN EXTERNAL FEED-

BACK LOOP, Bernard Villeneuve, Pierre Tremblay and Michel Tetu, Departement de genie electrique, Universite Laval, Ste-Foy, Quebec, Canada

6. PRECISION MILLIMETER WAVE MEASUREMENTS OF REFRACTIVE INDEX AND DIELECTRIC PERMITTIVITY, Mohammed Nural Afsar, Massachusetts Institute of Technology, Francis Bitter National Magnet Laboratory, Cambridge, MA

7. RESONANT WINDOW METHOD TO MEASURE THE PERMITTIVITY OF THIN SHEET MATERIALS, A. Kumar, Spar Aerospace Ltd, Quebec, Canada

8. INFRARED DETECTION OF MICROWAVE SCATTERING AND DIFFRACTION, Ronald M. Sega, Department of Electrical Engineering, University of Colorado, Colorado Springs, Colo

9. DESIGN AND PERFORMANCE OF HELMHOLTZ COILS FOR MAGNETIC FIELD MEASUREMENTS, V. V. Liepa, B. Dykaar and J. Go, Department of Electrical and Computer Engineering, Radiation Laboratory, The University of Michigan, Ann Arbor, MI

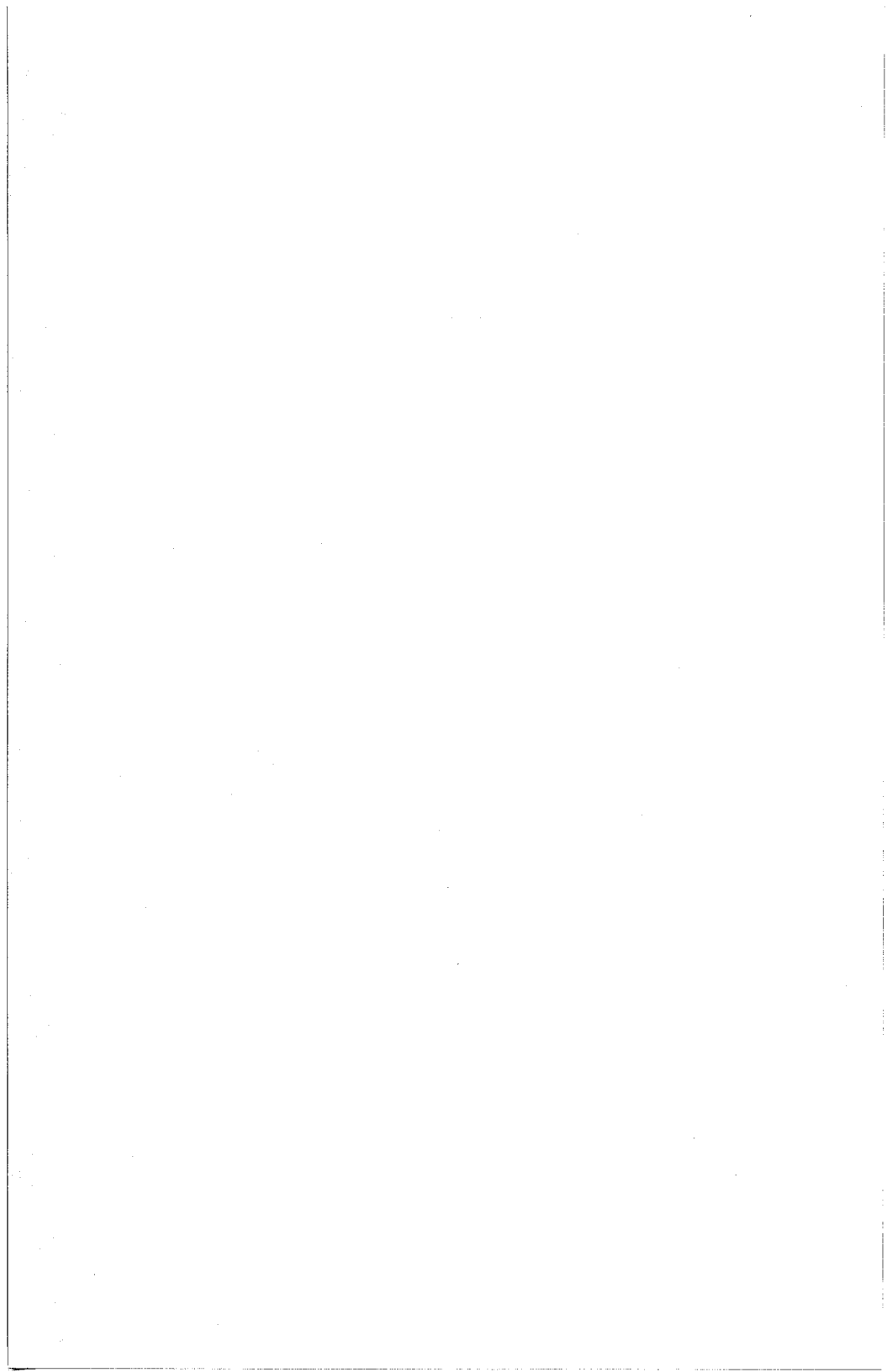

SPHERICAL SURFACE SAMPLING

Edward B. Joy and James B. Rowland, Jr.
School of Electrical Engineering
Georgia Institute of Technology
Atlanta, Georgia 30332-0250

The standard sample spacing requirement for spherical surface near-field measurements has been found to be insufficient in almost all cases investigated. The number of spherical modes used to represent the sampled field is likewise not well established and often not conservative. Results of insufficient sampling and an insufficient number of modes for calculation of far-field patterns from spherical surface near-field measurements are displayed. Also displayed are the effects of insufficient separation between the antenna under test and the near-field probe. Computer simulation results for a variety of phased array near-field measurements are used to suggest a new maximum sample spacing requirement, a required minimum number of spherical modes and a minimum separation between the antenna under test and the near-field probe.

Several theoretical, computer simulation and empirical studies have been conducted to determine the requirements for probe position accuracy for near-field measurements. The recommended positional requirements for the radius of the measurement sphere including any offset between the two axes of spherical rotation, and for the accuracy of the angular sampling locations are shown not to be conservative and new positional requirements are presented.

A probe position error compensation technique, called the R-correction technique, has been developed in which all near-field energy is assumed to propagate in the radial direction for the purpose of probe position error compensation. Each near-field sample is assumed to represent the amplitude and phase of a simple spherical wave propagating in the local radial direction. Ideally positioned samples, those at integer multiples of the two angular sample increments and at constant radius, are determined from the measured sample by evaluating the spherical wave at the ideal position. This R-correction technique is, thus, an approximation, but has proven to be highly successful. The R-correction technique can be upgraded, to remove the assumption of radial only propagation. The technique for probe position error compensation relies on accurate probe position data for each near-field measurement. This position information must be obtained from an auxiliary position measurement system. Results of the application of the probe position error compensation technique are presented and show good performance for up to one wavelength radial error, where the error is known to within one five-hundredths of a wavelength.

URSI/A-I-2

EVALUATION OF MICROWAVE ANECHOIC CHAMBER MEASUREMENT

Motohisa Kanda and R. David Orr
National Bureau of Standards
Electromagnetic Fields Division
Boulder, CO 80303

The electromagnetic field measurements in an anechoic chamber are usually performed in the near-field region of a transmitting standard antenna. The approach used to establish a standard field is to calculate the radiated field intensity in the near-field region of standard antennas. These antennas consist of a series of open-ended waveguides below 500 MHz and a series of rectangular pyramidal horns above 500 MHz. In this paper the anechoic chamber measurement is evaluated in terms of the net power delivered to a standard transmitting antenna, the near-zone gain of a standard, open-ended rectangular waveguide or rectangular pyramidal horn, and reflections within the chamber.

To determine the net power delivered to a standard transmitting antenna, we perform two power ratio measurements with a standard short and a matched termination. Once the system S-parameters and the system reflection coefficients are determined, the net power delivered to the standard transmitting antenna is then determined from two absolute power measurements.

The near-zone gain of a standard, open-ended, unflanged rectangular waveguide is calculated from forward near-field power patterns, which are determined from theoretically predicted far-field power patterns by use of the plane wave scattering theorem.

In deriving the near-zone gain of a pyramidal horn by the Kirchoff method, Schelkunoff accounted for the effect of the horn flare by introducing a quadratic phase error in the dominant mode field along the aperture axes. The geometrical theory of diffraction improves Schelkunoff's equation by accounting for the reflection of fields diffracted from the horn interior and field doubly diffracted from the horn aperture. This equation then determines the on-axis near-field gain of a pyramidal horn.

The failure of an anechoic chamber to provide a perfect free-space test environment affects the accuracy in the anechoic chamber measurements. The performance of a rectangular anechoic chamber can be checked by measuring the relative insertion loss versus separation distance between a source antenna and a receiving antenna. Disagreement between the measured insertion loss and the calculated free-space transmission loss is a measure of reflections from the chamber surfaces. This paper discusses the methodology for evaluating anechoic chamber measurements.

A MODULAR TESTBED DESIGN OF A HIGH RESOLUTION POLARIZATION RADAR FOR TARGET IN CLUTTER DETECTION AND DESCRIPTION

Robert M. Lempkowski and Wolfgang-M. Boerner
Electromagnetic Imaging Division
Communications Laboratory/SEL 4210
Dept. of Electrical Engineering &
Computer Science/SEO 1141
University of Illinois at Chicago
851 S. Morgan St.
P.O. Box 4348
Chicago, IL 60680

Recent developments in radar polarimetry have generated diverse requirements for system design. Special purpose radars have proven key aspects of the expanding use of dual orthogonal theoretical work. A system which can accommodate varieties of polarization diverse operating modes is required to further expand this capability by providing insights into target and/or clutter depolarization properties. Improvements with regard to real-time viewing of processed data is imperative for system and operator interaction to optimize algorithms of the various operating modes (R.M. Lempkowski, M.Sc. Thesis, June 1984).

This system proposal entails the use of a variable ellipsometric polarization transmitter and a receiver which displays return polarization operating from 2-18 GHz. Transmission can be routed into the receiver for system calibration error correction, and resulting real time depolarization display utilizing digital controlled switch, phase and amplitude networks located in both the transmitter and receiver. The display format is the Poincaré sphere itself, and the vector information of co-pol nulls is available for immediate order processing when formed via transmission of variable polarizations. Separate orthogonal channels are available in the receiver to monitor x-pol information as well as prove correctness of co-pol ratio returns of the display.

In addition to functioning as a polarimetric radar, additional modes to be used separately for investigation are:

1. Individual orthogonal doppler channels
2. Amplitude and frequency modulation for ramp, chirp and other compressive modes
3. Polarization modulation ability (digital) for communication or serrodyne

Since the receiver has the orthogonal channels available, the possibility exists for growth into the following areas:

1. Upconvert/downconvert to higher frequency capability with an odd common IF
2. Employ use of other special-purpose hardware such as logic-product null suppression techniques
3. Combinations of techniques, chirp filter hardware, etc.

URSI/A-I-4

An Integrated WR22 Resolver Style 6-Port for Making Accurate
Reflection Coefficient Measurements over the Band 33-50 GHZ

Gordon P. Riblet
Microwave Development Laboratories, Inc.

Abstract

In this paper a compact WR22 6-port coupler for making accurate reflection coefficient measurements over the band 33-50 GHZ will be described. This is a frequency range for which simultaneous amplitude and phase measurements have traditionally been difficult and expensive, and which includes the 44 GHZ band which is of increasing commercial importance. The 6-port coupler is a compact integrated assembly including 4 diode detector mounts. Because of its compact construction style the 6-port calibration constants vary only slowly as a function of frequency. As a result frequency control beyond wavemeter accuracy is not required in order to make accurate amplitude and phase measurements. The measurement system itself includes a Micro-Now 33-50 GHZ sweeper with an IEEE bus, an HP9816 16 bit computer, and a PMI 1038 scalar analyser with the IEEE bus. The channel B plug-in of the PMI is replaced with a custom built switch box which can be controlled by the HP9816 and switches in turn 3 of the detectors of the 6-port to the channel A plug-in of the PMI. Smith Chart plots based on 50 frequency points or plots of amplitude or phase vs frequency can be displayed on the screen of the HP9816 in less than 10 seconds after measurements begin. Some measurement results will be presented at the symposium.

MODIFICATION OF THE SPECTRAL DENSITY OF THE THERMAL NOISE
WITHIN A MICROWAVE CAVITY EQUIPPED WITH AN EXTERNAL FEEDBACK
LOOP.

Bernard Villeneuve, Pierre Tremblay and Michel Têtu
Laboratoire de Recherche sur les Oscillateurs et Systèmes
Département de génie électrique
Université Laval, Ste-Foy, P. Québec
Canada G1K 7P4

An experimental study of the spectral density of the thermal noise within a microwave cavity equipped with an external feedback loop to enhance the cavity Q is presented. The spectral density is measured for various values of the loop parameters (gain and phase). It is shown that this density can be far different from the expected Lorentzian shape.

Using the two-port equivalent for each element, a theoretical model of the system is developed. This model allows the evaluation of the spectral density of the thermal noise at any port along the system. Comparison between the measured values and the calculated values of the spectral density is given.

The measurement procedure and the theoretical model presented can be extended to evaluate the performances of the system used as a cavity-oscillator. Both microwave spectrum and frequency stability are to be considered.

URSI/A-I-6

PRECISION MILLIMETER WAVE MEASUREMENTS OF REFRACTIVE INDEX AND DIELECTRIC PERMITTIVITY

Mohammed Nurul Afsar

Massachusetts Institute of Technology
Francis Bitter National Magnet Laboratory
Cambridge, Massachusetts 02139

Abstract

It is no longer necessary to use extrapolated microwave dielectric values when designing millimeter wave components and systems. Recent measurements at MIT have shown that low-loss millimeter wave materials can be characterized accurately across the continuous spectrum from 60 GHz to 400 GHz. Our refractive index measurements of glasses, ceramics and semiconductors have been accurate and reproducible to six significant figures. This accuracy is sufficient to distinguish differences among nominally identical specimens such as siblings in a batch of material, different sources of the same material, different methods of preparation, different aging processes and environmental changes in properties caused by assimilation of water vapor or chemical pollutants. The absorption coefficient of these low-loss materials have been measured to an accuracy of at least one percent. The real and imaginary parts of the Complex Dielectric Permittivity and also the loss tangent values of these materials have been derived via Maxwell's celebrated relation $\hat{\epsilon} = (\hat{n})^2$ from the directly obtained absorption coefficient and refractive index values. These measurements were carried out employing dispersive Fourier transform spectroscopy applied to a modern modular polarization type two-beam interferometer.

RESONANT WINDOW METHOD TO MEASURE THE
PERMITTIVITY OF THIN SHEET MATERIALS

A. Kumar
Antenna Engineering
Spar Aerospace Ltd.
21025 Trans-Canada Highway
Ste-Anne-de-Bellevue
Quebec
Canada H9X 3R2

The aim of this paper is to develop an accurate method for determining dielectric properties of thin sheets of various dielectric material. The cavity perturbation method has been found suitable for the measurement of the relative permittivity of thin sheets of materials [1]. In this method, the measurement is performed by inserting the sample sheet into a cavity resonator and determining the properties of the sample from the resultant change produced in the resonant frequency and the quality factor. In the cavity method, there is a need for a perfect fitting of the sample into the waveguide and an error is introduced due to this assumption.

To overcome this error, we have developed a new technique in which there is no need for a perfect fitting of the sample into the waveguide. In this method a tuned window [1] is placed in a rectangular waveguide and a thin piece of dielectric sheet is placed close to it. We can show easily that the tuned window and sample can be expressed as a susceptance (jB) across the equivalent transmission line for the first order approximation of the sample thickness and a negligible thickness of window, assuming that only a dominant mode TE_{10} is permitted to propagate in the waveguide.

To calculate the relative permittivity, we require to know the size of the resonant window, thickness of the dielectric material and the resonant frequency. The experimental results of thin sheets of Stycast Hik and Legkowied glue have been reported and a detailed discussion will be given at the Conference.

REFERENCES

[1] A. Kumar and D. G. Smith, IEE Conference Publication No. 129, 151-154, 1975.

INFRARED DETECTION OF MICROWAVE SCATTERING AND DIFFRACTION

Ronald M. Sega
Department of Electrical Engineering
University of Colorado
Colorado Springs, Colorado 80933

An infrared (IR) measurement technique originally developed for the detection of surface currents on complex shapes has been extended to the detection of scattering and diffraction phenomena of electromagnetic (EM) waves in the 2-4 GHz range. A resistive paper (approximate resistance = $1500 \Omega / \square$ and thickness = $80 \mu\text{m}$) is used as the detection medium whereby the resultant electric field interacts with this material screen, producing joule heating observable with an IR system. A flat, resistive screen ($1\text{m} \times 2\text{m}$), mounted on a styrofoam board, was placed in the scattering or diffraction plane of interest.

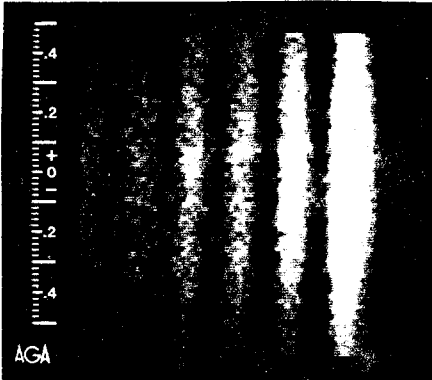

Figure 1: Thermogram

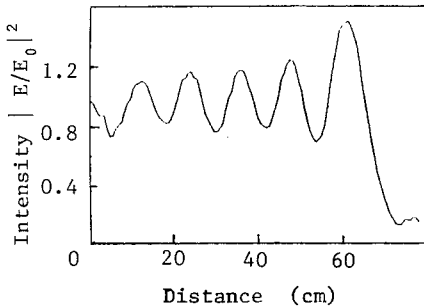

Figure 2: Intensity Plot (Empirical)

Several classic experimental situations were investigated and the results are presented. These include scattering from cylinders, Young's double-slit demonstration, and Fresnel diffraction from a straight edge of a half-plane which is depicted in figures 1 and 2. Corrections for ambient thermal conditions and incident wave characteristics, and multiple frame averaging techniques are presented. Correlation of the empirical results such as depicted in figure 2 with theoretical predictions is encouraging. The direction of this research is toward the analysis of EM scattering and diffraction from complex structures and the development of interferometric techniques to measure phase and amplitude. Potential applications of infrared detection techniques to more general EM problems are also discussed.

DESIGN AND PERFORMANCE OF HELMHOLTZ COILS FOR MAGNETIC FIELD MEASUREMENTS

V. V. Liepa, B. Dykaar and J. Go
Radiation Laboratory
Department of Electrical and Computer Engineering
The University of Michigan
Ann Arbor, MI 48109

The surface current measurements whether performed in a frequency or time domain facility do not usually provide data at low frequencies and, in particular, at zero frequency or dc. If available, such data will extend to zero the measured transfer function data curves, such as those for the surface current induced on an aircraft by an incident electromagnetic wave, and in SEM analyses will provide the value of the residue at zero frequency.

To generate a test region of a uniform magnetic field in a low MHz frequency range a Helmholtz coil design was selected. The test region is cylindrical and is 12 inches in diameter and 12 inches in length, where the field should not deviate more than five percent. From the dc analysis it was determined that to meet these requirements a pair of coils four feet in diameter and two feet apart would be required. To obtain the uniform field at a relatively high frequency (10 - 20 MHz) it is essential that the phase and amplitude of the current in each of the two loops be constant and such was accomplished by using four driving points on each of the two loops.

Two designs, differing in the manner in which the driving points are implemented, were constructed and evaluated. In the first design the loops are closed (rings, no gaps) and the excitation is provided by eight current transformers placed 90 degrees apart on each coil. The eight transformers, in turn, are fed equally in phase and amplitude from an 8-port power splitter. In the second design each of the coils are excited by four equally spaced gaps on each coil, which, in turn, are fed from within the conductors (coils) made of semi-rigid coaxial cable. Here differential signals are needed and these are obtained from a transformer/power splitter circuit.

In the presentation the two designs and comparison of their performance will be discussed. Sample measurements of the magnetic field on simple shapes will be presented.

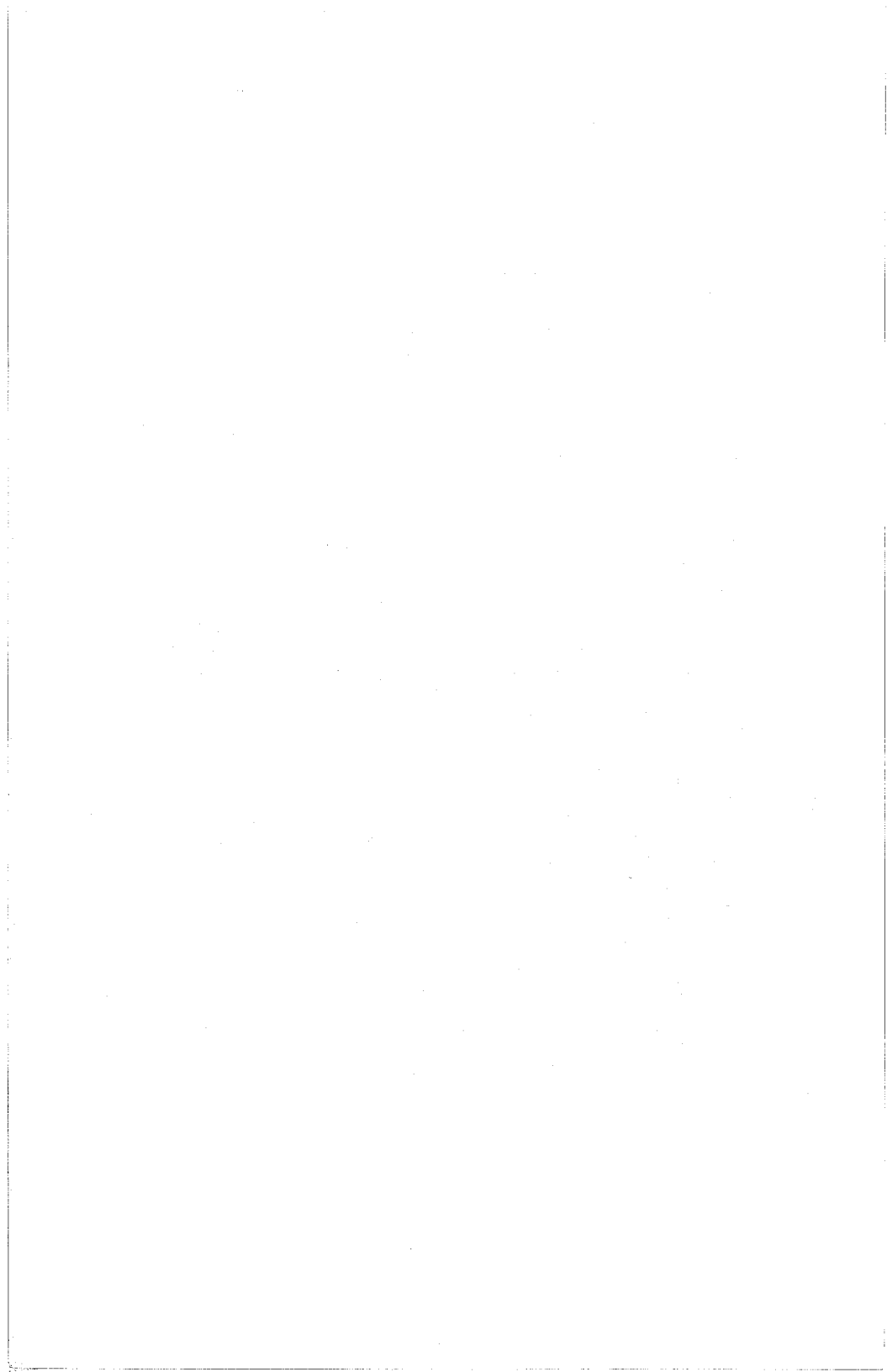

URSI COMMISSION B SESSION B-17



IMAGE IDENTIFICATION

Thursday, June 28 1:30 - 5:00 P.M.

Room: ST. GEORGE, A, B

Chairman: Arthur Jordan

**Naval Research Laboratory, Washington,
D.C.**

1. METHODS FOR K-PULSE ESTIMATION, E. M. Kennaugh, N. Wang, and D. L. Moffatt, The Ohio State University ElectroScience Laboratory, Department of Electrical Engineering, Columbus, OH

2. THE K-PULSE AND RESPONSE WAVEFORMS FOR NON-UNIFORM TRANSMISSION LINES, E. M. Kennaugh, D. K. Moffatt, and N. Wang, The Ohio State University ElectroScience Laboratory, Department of Electrical Engineering, Columbus, OH

3. A CLASSIFICATION ANALYSIS OF HIGH RESOLUTION POLARIMETRIC TARGET DOWNRANGE SIGNATURES BASED ON KENNAUGH'S POLARIMETRIC TARGET CHARACTERISTIC OPERATOR THEORY, Anthony C. Manson and Wolfgang-M. Boerner, Electromagnetic Imaging Division, Communications Laboratory, Dept. of EE & CS, University of Illinois at Chicago, Chicago, IL

4. PERFORMANCE OF TWO TARGET CLASSIFICATION TECHNIQUES FOR HF OTH RADARS, J. S. Chen and E. K. Walton, The Ohio State University ElectroScience Laboratory, Columbus, OH

5. LAMBERT, MOLLWEIDE AND AIT-OFF PROJECTIONS OF THE POLARIZATION SPHERE AND ITS APPLICATION TO RADAR POLARIMETRY, Xiao-Quin Huang and Wolfgang-M. Boerner, Electromagnetic Imaging Division, Com-

munications Laboratory, Dept. of EE & CS, University of Illinois at Chicago, Chicago, IL

6. A UNIFIED APPROACH TO OBJECT CLASSIFICATION FROM SCATTERED WAVE MEASUREMENTS, G. D. Poe, E. K. Miller, Lawrence Livermore National Laboratory, Livermore, CA

7. ON THE PRACTICALITY OF RESONANCE-BASED IDENTIFICATION OF SCATTERERS, J. R. Auton, M. L. Van Blaricum, and T. L. Larry, General Research Corporation, Santa Barbara, CA, M. A. Morgan, Naval Postgraduate School, Monterey, CA

8. TARGET RECONSTRUCTION FROM NATURAL FREQUENCIES, C. Eftimiu and P. L. Huddleston, McDonnell Douglas Research Laboratories, St. Louis, MO

9. ERROR ANALYSIS OF RADAR SCATTERING MATRIX MEASUREMENTS, Sasan S. Saatchi and Wolfgang-M. Boerner, Electromagnetic Imaging Division, Communications Laboratory, Dept. of EE & CS, University of Illinois at Chicago, Chicago, IL

10. SIGNAL PROCESSING FOR INVERSE SCATTERING UNDER THE KIRCHHOFF ASSUMPTION, K.J. Langenberg, M. Fischer, K. Mayer, G. Weinfurter, P. Xanger, Department of Electrical Engineering, University of Kassel, Kassel, W. Germany



METHODS FOR K-PULSE ESTIMATION

E.M. KENNAUGH, N. WANG AND D.L. MOFFATT
The Ohio State University ElectroScience Laboratory
Department of Electrical Engineering
Columbus, Ohio 43212

The purpose of this paper is to briefly describe and illustrate certain methods for estimating the K-pulse waveform. In particular, a method for approximation of the K-pulse by an equally-spaced train of $2M+1$ impulses over a finite interval will be discussed and illustrated for a known K-pulse.

Approximation of a K-pulse by a finite Fourier series will also be discussed and results compared with the impulse train approach. Finally, we will discuss special cases which occur for zero distributions which asymptotically continue to diverge from the imaginary axis (although remaining within an infinitesimal angle of that axis). This type of zero distribution occurs for the complex resonances of the perfectly conducting sphere.

URSI/B-17-2

THE K-PULSE AND RESPONSE WAVEFORMS FOR NON-UNIFORM TRANSMISSION LINES

E.M. KENNAUGH, D.L. MOFFATT, AND N. WANG
The Ohio State University ElectroScience Laboratory
Department of Electrical Engineering
Columbus, Ohio 43212

The purpose of this paper is to illustrate the application of the K-pulse concept to a class of distributed-parameter systems which can be modelled by finite lengths of non-uniform transmission lines. The K-pulse of such a system is the excitation (input) waveform of finite duration which yields response waveforms of finite duration at all points of the system. We shall use delay line with fixed delay, which permits the final R-matrix of the system to be expressed in terms of polynomials in the variable $z = \exp(-2s\tau)$, where τ is the element delay.

Numerical techniques using finite element methods are developed to derive accurate approximation of the K-pulse and response waveforms for uniform and non-uniform transmission lines. We are interested in the convergence of the waveforms as N , the order of the polynomials, is increased. We are also interested in the limiting form of these waveforms as $N \rightarrow \infty$, and how accurately this limiting form may be extrapolated from a finite element model with N less than 50. Comparison is made with exact results, where these can be obtained using other methods, to illustrate the accuracy and utility of the method.

A CLASSIFICATION ANALYSIS OF HIGH RESOLUTION POLARIMETRIC TARGET DOWNRANGE SIGNATURES BASED ON KENNAUGH'S POLARIMETRIC TARGET CHARACTERISTIC OPERATOR THEORY

Anthony C. Manson and Wolfgang-M. Boerner
Electromagnetic Imaging Division
Communications Laboratory/SEL 4210
Dept. of Electrical Engineering &
Computer Science/SEO 1141
University of Illinois at Chicago
851 S. Morgan St.
P.O. Box 4348
Chicago, IL 60680

Basic polarimetric backscattering characteristics of simple to increasingly more complex shaped missile-type targets are analyzed and interpreted by adhering strictly to Kennaugh's target characteristic operator concept and Huynen's target Mueller-matrix decomposition theories.

Scatterer model data are computer-generated on the DEC-VAX 11/750 Research Computer Processing System at the Communications Laboratory and compared with measurement data for missile-type composite targets collected on the Teledyne-Micronetics range for the S-band (2.4 to 4 GHz in steps of 25 MHz) and X-band (9 to 10.6 GHz) for vertical (V) and horizontal (H) antenna polarization state basis as described in Morgan and Weisbrod (1982).

Major emphasis is placed on extracting basic polarimetric scattering/diffraction centers of single isolated composite targets of missile shape as functions of aspect and incremental down range resolution. The obtained results are reinterpreted (A.C. Manson, May 1984) with the objective of assessing the potential of utilizing complete polarimetric target downrange signatures as input function for target characteristic classifiers.

URSI-Commission B: Inverse Scattering

URSI/B-17-4

PERFORMANCE OF TWO TARGET CLASSIFICATION TECHNIQUES FOR HF OTH RADARS

J.S. Chen and E.K. Walton

The Ohio State University ElectroScience Laboratory
Department of Electrical Engineering
1320 Kinnear Road
Columbus, Ohio 43212

It has been shown that radar returns in the resonance region (eg: with wavelengths ranging from $1/10$ to 10 times the size of the radar target) carry information regarding the overall dimensions and shape of the radar targets. This paper discusses radar target classification techniques developed to utilize such data as radar target signatures for aircraft, ships, and missiles.

Two classification techniques will be discussed here. Both of these techniques utilize resonance region radar measurements of the radar cross section (RCS) and intrinsic target backscattered phase. The RCS of the unknown targets are included in a previously generated catalog of RCS and phase measurements. The catalog used for this paper was generated using RCS measurements of scale models of modern aircraft and naval ships using a radar range at Ohio State University. The unknown targets have their RCS and phase taken from the data base and corrupted by errors to simulate real-world full-scale propagation path and processing distortion. Examples will be shown.

The first technique uses nearest neighbor algorithms on the RCS magnitude and (range corrected) phase at a number (eg: 2, 4, or 8) of operating frequencies. The second technique uses inverse Fourier transformation into the time domain followed by cross correlation. Comparisons of the performance of the two techniques as a function of signal to error ratio for various processing options will be given.

LAMBERT, MOLLWEIDE AND AITOFF PROJECTIONS OF THE POLARIZATION SPHERE AND ITS APPLICATION TO RADAR POLARIMETRY

Xiao-Qing Huang and Wolfgang-M. Boerner
Electromagnetic Imaging Division
Communications Laboratory/SEL 4210
Dept. of Electrical Engineering &
Computer Science/SEO 1141
University of Illinois at Chicago
851 S. Morgan St.
P.O. Box 4348
Chicago, IL 60680

In the application of basic scattering matrix theories such as Kennaugh's target characteristic operator formulation to radar polarimetry, optimal polarization states need to be displayed on the Poincaré polarization sphere. Although such a three-dimensional presentation of a radar target's characteristic operator (polarization fork) is most illustrative, in practice two-dimensional projections are usually more desirable; and here we will apply modern and advanced methods of cartographic projection theory for the purpose of determining which planar projection can be used efficiently next to the standard polar map projection.

Specifically, we will discuss techniques of presenting power and voltage relationships on the Poincaré polarization sphere on two-dimensional planar maps using various projection algorithms. With the assumption of only being concerned with the specific location of a polarization state on the polarization sphere rather than its intensity, we normalize the Poincaré sphere to be a unit sphere so that a reduction from the three-dimensional projection can be facilitated. Various known geographical mapping techniques are applicable in this case which differ in such properties as the shape, the size, the area distortion of specific regions on the sphere (X-Q. Huang, M.Sc. Thesis, June 1984). In general, those techniques can be set in order of four categories, namely: Azimuthal, Cylindrical, Conic, and Elliptical. The characteristics of these techniques are discussed, associated computer graphical software was developed, as well as applied documentation and implementation analyses for many polarimetric radar applications are introduced. Specifically, the standard polar projection, various Lambert projections, the elliptical Aitoff and Mollweide approaches are considered in detail.

Finally, using experimental and computer model generated data, these various projection techniques are applied to practical situations, and their relative merits are being discussed and compared.

URSI-B: Analytical & Numerical Techniques

URSI/B-17-6

A UNIFIED APPROACH TO OBJECT CLASSIFICATION FROM SCATTERED WAVE MEASUREMENTS*

G. D. Poe, E. K. Miller

Lawrence Livermore National Laboratory
P.O. Box 5504, L-153, Livermore, CA 94550

Abstract

Inverse problems have as their usual goal that of obtaining the source distribution and object geometry which produced the observed (usually) far field. This very general problem may be simplified if the less ambitious goals of object classification (does the data observed place the object in the class of interest?) or object identification (if in the class of interest, which particular object is it?) are substituted.

Many different approaches have been developed for the inverse problem, two of which are discussed here, ramp-response (early-time) profile estimation, and resonance-response (late time) pole estimation. The former exploits the fact that a ramp field incident on a convex object produces a scattered field whose time dependence is proportional to the cross sectional area as seen by a plane moving through the object. The latter by contrast utilizes the source-free response of the object, the poles of which are the object resonances. These two data regimes can provide complimentary ways to approach object identification and geometry estimation.

After presenting some introductory material, we discuss some specific attributes of each approach. Although a ramp response deals with early-time fields, the ω^{-2} energy spectrum of the incident field necessarily limits the maximum useful frequency and consequently the spatial resolution it can provide. On the other hand, the free response depends on the object's "Q" being high enough that the scattered fields persist sufficiently long for the poles (or their equivalent) to be estimated. This requirement results in limiting accurately useful pole estimation to a region near the $j\omega$ axis. By constraining the poles to a parametric curve in the complex s -plane, it is possible to extend the useful pole region by exploiting redundancy in the object's frequency response. These and other aspects of ramp and resonance responses will be discussed with respect to implications for practical utilization.

*Work performed under the auspices of the U. S. Department of Energy by the Lawrence Livermore National Laboratory under contract number W-7405-ENG-48.

ON THE PRACTICALITY OF RESONANCE-BASED IDENTIFICATION
OF SCATTERERS

by J.R.Auton, M.L.Van Blaricum, and T.L.Larry
General Research Corporation
Santa Barbara, CA

and M.A.Morgan
Naval Postgraduate School
Monterey, CA

The practicality of resonance-based identification of electromagnetic scatterers is explored through measurements of monostatic scattering from the two stick-model scatterers shown below. These scatterers are representative of two different aircraft that are to be discriminated or identified. Numerical predictions for these same scatterers were carried out to validate the measurements and quantities derived from the measurements. Clusters of natural frequencies (Laplace-domain poles) have been formed for each scatterer with data from different measurements. The mutual exclusiveness of the clusters is an indication of the practicality of resonance-based identification.

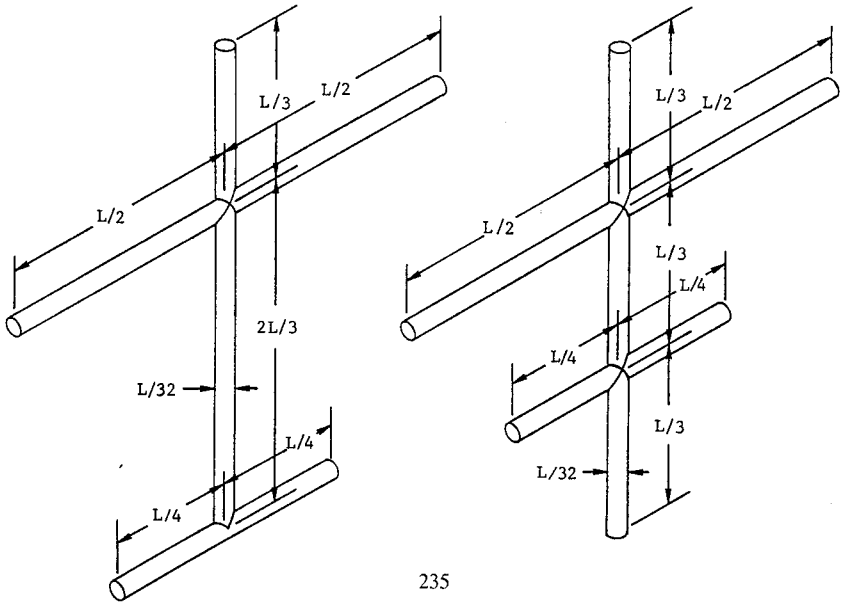

TARGET RECONSTRUCTION FROM NATURAL FREQUENCIES

C. Eftimiu and P. L. Huddleston
McDonnell Douglas Research Laboratories
St. Louis, MO 63166

Inverse scattering theory is used to reconstruct radially distributed refractive indices from natural frequencies. Only the case of scalar waves is discussed, although the extension to electromagnetic waves is straightforward (C. Eftimiu, NATO Advanced Research Workshop, Bad Windsheim, Sept. 1983). The scalar Helmholtz equation governing the scattering is transformed by a Liouville transformation into a quantum mechanical Schrödinger-like equation [C. Eftimiu, *J. Math. Phys.*, 23, 2140-2146, (1982)] for which a complete inverse scattering theory exists. The inverse theory based on the Marchenko equation proceeds from the scattering matrix to the solution of an integral equation to determine the scattering potential from which the index of refraction is recovered by an inverse Liouville transformation. Two methods of expressing the scattering matrix in terms of natural frequencies are studied: an (infinite) Weierstrass product representation and an (infinite) Mittag-Leffler summation representation. The efficacy of the truncated forms of these representations is explored. For the case under consideration (finite range potentials) an asymptotic formula for the high-order natural frequencies is known [J. Humblet, *Mem. Soc. Roy. Sci. Liège*, 12, 9-119, (1982)]. Thus, if many natural frequencies are required for a satisfactory reconstruction, but only a relative few are available from experimental data, one can estimate as many more as are required. This approach provides a convenient context in which to assess the effect that perturbing a set of natural frequencies has on the reconstructed index of refraction. Possible perturbations could involve simply changing the location of one or more of the natural frequencies, adding extra natural frequencies to the set or removing natural frequencies from the set. Some preliminary results on the effects of such modifications will be presented.

ERROR ANALYSIS OF RADAR SCATTERING MATRIX
MEASUREMENTS

Sasan S. Saatchi and Wolfgang-M. Boerner
Electromagnetic Imaging Division
Communications Laboratory/SEL 4210
Dept. of Electrical Engineering &
Computer Science/SEO 1141
University of Illinois at Chicago
851 S. Morgan St.
P.O. Box 4348
Chicago, IL 60680

In studying the radar polarization matrix for determining characteristics of a radar scatterer, an error analysis is developed which establishes a set of constraints on the various considered error quantities. The specific error quantities chosen, are those which are expected to affect measurements most seriously (S.S. Saatchi, M.Sc. Thesis, June 1983) and may be defined by

1. improper antenna polarization
2. geometry of measurement set-up
3. sidelobe interference
4. calibration procedures

Using a linear (H,V) antenna polarization state basis, it is shown that the errors of improper antenna polarization can be expressed in terms of a 2x2 relative phase radar polarization scattering matrix. For various specific object shapes the error effects on the RCS and power returned from the scatterer is compared to the ideal case. It is shown that for objects with no intrinsic depolarization effects, this error will generate cross polarized terms in the scattering matrix which, however, can be removed by using the calibration methods introduced. Specifically, we have shown that for reducing measurement errors in scattering matrix measurements one need to use simple known calibration objects other than spheres, because the scattering matrix of the sphere is not suitable for analyzing depolarization effects.

URSI-A: Microwave and Millimeter Wave Measurements

URSI/B-17-10

Signal processing for inverse scattering
under the Kirchhoff assumption

K.J. Langenberg
M. Fischer
K. Mayer
G. Weinfurter
P. Zanger

Department of Electrical Engineering, FB 16
University of Kassel
3500 Kassel, FRG

For convex or even smooth star-shaped scatterers the Kirchhoff or Physical Optics assumption can be utilized to derive a couple of inverse scattering algorithms, the most well-known ranging under the acronym POFIS, for Physical Optics Far-Field Inverse Scattering: a monostatic broadband experiment is assumed and signal processing is in terms of a multidimensional spatial Fourier transform from K -space to reconstruction space. A bistatic counterpart can be derived heuristically leading to Fourier-Holography or FIFFIS (Frequency Independent Far-Field Inverse Scattering), and its results are comparable to aperture-limited POFIS. Limiting the bandwidth as well yields the backward wave propagation algorithm Generalized Holography where now only the real and imaginary part of the scattered field, i.e. fewer data, have to be processed, but only plane scatterers can be imaged that way, because the backward wave propagation argument holds only if a one-dimensional formulation of scattering in terms of a spectral wave decomposition is possible.

Instead of spatial Fourier processing a time domain data registration and signal summation according to travel times might be performed alternatively and interpreted as a correlation procedure: starting with the POFIS-identity, the Synthetic Aperture Radar is derived. Generalizing the procedure to the near-field, Fourier processing is once again possible if an additional interpolation is included.

The above statements are supported by (scalar) computational results for a variety of scatterer shapes.

AP-S/URSI AUTHOR INDEX

- Aboul-Atia, O., UB-3, 27
 Abramo, G., UF-2, 141
 Acosta, R., UB-4, 42
 Adams, W. R., AP-9, 305
 Aditya, S., AP/F-3, 654
 Afsar, M. N., UA-1, 222
 Agrawal, A. P., AP-2, 37
 Akimov, V. P., UB-1, 7
 Alanen, E., UB-1, 7, 8
 Alexopoulos, N. G., AP-15, 563, 566;
 AP-24, 879; UB-11, 128
 Alfredson, L. A., AP-5, 155
 Altintas, A., UB-4, 39
 Antebi, J., AP-20, 777
 Apponi, G., UF-2, 141
 Arndt, G. D., AP-10, 341
 Arora, R. K., AP-6, 205; AP/F-3, 654
 Auton, J. R., UB-17, 235
 Awaka, J., AP/F-3, 650
- Bagby, J. S., UB-7, 41, 70
 Bahar, E., AP-2, 41
 Baker, D. E., AP-6, 173
 Balling, P., AP-5, 139
 Banfuku, K., AP-18, 720
 Bang, X. X., UB-9, 92
 Bansal, R., UB-9, 89
 Barnes, J. C., UF-1, 105
 Basili, P., UB-15, 191
 Bathker, D. A., AP-20, 767
 Bayha, W., AP-6, 181
 Beker, B., UB-2, 16
 Bevensee, R. M., UB-15, 183
 Bertoni, H. L., UB-16, 209
 Besieris, I. M., UB-13, 168
 Bhattacharyya, A. K., AP-7, 242, 246;
 AP-15, 584
 Blake, J., AP-5, 158
 Boerner, W.-M., AP-1, 31; AP-2, 37;
 AP-23, 863; UB-2, 16; UB-5, 51;
 UB-15, 188; UA-1, 219; UB-17, 231,
 233, 237
 Boldissar, F., AP-5, 155
 Bondyopadhyay, P. K., UB-2, 22; UB-11,
 129
 Boodaghians, S., AP-21, 803
 Bornemann W., AP-5, 139
 Borowick, J., AP-6, 181
- Bostian, C. W., AP/F-4, 655; AP/F-3,
 195
 Botha, L., AP-6, 173
 Bowley, C. J., UF-1, 106
 Bradshaw, S. E., AP-3, 62
 Briancon, A. C., UB-15, 184
 Breakall, J. F., UB-1, 5
 Bridges, E., AP-15, 573
 Bridges, G., UB-3, 27
 Brittingham, J. N., UB-8, 85
 Brown, A. C., UB-16, 214
 Brown, G. S., UB-5, 50
 Brown, M. F., UB-9, 91
 Brown, R. C., AP-13, 494
 Brown, S. H., UB-13, 165
 Brown, W. C., AP-10, 339
 Bui-Hai, N., AP-16, 620
 Burke, G. J., UB-1, 5
 Burke, H. K., UF-1, 105
 Burnside, W. D., AP-1, 3; AP-23, 855;
 UB-10, 115
 Burt, E. C., UB-4, 45
 Burton, R., King Session, 446
 Butler, C. M., UB-9, 92, 95; UB-16, 208
 Buyukdura, O. M., AP-7, 223
- Cai, L., AP-2, 45
 Cagnon, R., AP-5, 143
 Cain, C. A., AP-6, 197
 Calla, O. P. N., UF-2, 137
 Calmon, L. C., AP-12, 405
 Cangellaris, A. C., UB-8, 77
 Carpenter, E. W., AP-16, 591
 Carrillo, S. E., AP-13, 474
 Cavanaugh, R. W., UF-2, 139
 Cassel, E., UB-2, 21
 Cha, A. G., AP-20, 767
 Chadha, D., AP/F-3, 654
 Chaiken, S. S., UB-12, 152
 Chaloupka, H., UB-13, 163
 Chan, H. C., AP-21, 799
 Chang, D. C., UB-11, 132; King Session,
 445
 Chang, D. C. D., AP-9, 318; AP-21, 815
 Chang, F. C., AP-9, 301
 Chang, H.-T., AP-4, 113
 Chang, K. C., King Session, 437
 Chang, Y. C., AP-9, 293

Chapman, G. B., UF-1, 107
 Chatterjee, D., AP-7, 246
 Chandhuri, S. K., AP-1, 31
 Chen, C. H., AP-8, 251, AP-18, 724
 Chen, H., UB-12, 156
 Chen, J. S., UB-17, 232
 Chen, K. M., AP-1, 15, 19
 Chen, L. W., UF-1, 102
 Chen, S., AP-21, 815
 Chen, S. W., UF-1, 109
 Chen, Y-L., AP-20, 763
 Cheng, D. H. S., UB-2, 19
 Cheng, K. M., UF-1, 109
 Chew, W. C., UB-1, 9
 Chi, C. L., AP-24, 879
 Chiang, K. C., AP-7, 219
 Cho, Y. C., UB-7, 73
 Choung, Y. H., AP-13, 463; AP-16, 595
 Chu, R. S., AP-24, 886
 Chu, T. S., AP/F-3, 641
 Chuang, C. D., AP-7, 238
 Chuang, S. L., UB-7, 73
 Chung, H. H., AP-23, 855
 Ciotti, P., UF-2, 141, UB-15, 191
 Ciric, I. R., AP-18, 701
 Clark, J. V., AP-24, 886
 Clarricoats, P. J. B., AP-13, 486, 490,
 494
 Claspy, P. C., AP/F-3, 648
 Claverie, J., UF-4, 200
 Coe, R., AP-24, 871
 Cohen, H., AP-5, 143
 Cole, R. S., AP/F-3, 649
 Conforti, E. AP-3, 78
 Contu, S., AP-25, 929
 Cooke, W. P. AP-22, 837, 841
 Corey, L. E., AP-14, 507
 Cown, B. J., AP-23, 859
 Cox, D. C., UF-2, 144
 Crane, R. K., UF-1, 106, 107; UF-2,
 137, 138, 139, 140
 Crone, G. A. E., AP-20, 792
 Cwik, T., AP-25, 913, 921

 Dahele, J. S. AP-8, 279, 283
 Damaskos, N. J. AP-7, 235
 D'Archangelo, J. M., UB-13, 165
 Das, R. L., AP/F-3, 654
 Das, Y., AP-1, 11; AP-18, 701
 DaSilva, L. C., AP-9, 330
 Davey, K. R., UB-12, 155
 Davidovitz, M., AP-23, 863

 Davis, W. A., UB-5, 53
 Delevil, R., AP-2, 45; UB-13, 164
 D'Elia, G., AP-17, 678; AP-25, 945
 DeWitt, B., AP-1, 3
 DeWolf, D. A., UB-5, 57
 Dinger, R. J., AP-21, 807
 Dire, A., AP-4, 121
 Dirner, P. L., UF-4, 198
 DiTullio, J., King Session, 437
 Djordjevic, A. R., UB-3, 32
 Dobson, E. UF-2, 145
 Dong, T. L., UB-13, 166
 Drachman, B., AP-1, 27; UB-15, 189
 Dubost, G., AP-19, 753
 Dunn, A. G., AP-17, 662
 Dunn, J. M., AP-4, 101, 105
 Durney, C. H., AP-11, 363
 Dubdal, R. B., AP/F-3, 645; AP-24, 882
 Dykaar, B., UA-1, 225

 Eftimiu, C., UB-17, 236
 Elachi, C., AP-14, 543
 El-Khamy, S. E., AP-4, 117
 Elliott, R. S., AP-14, 515
 Elsherbeni, A. AP-7, 227; UB-4, 44
 El-Sherbiny, M., AP-3, 58
 Engheta, N., AP-14, 543
 Eom, H. J., UB-5, 58
 Ersoy, L., AP-6, 185
 Exum, N. L., AP-13, 463

 Farris, T. H., UB-9, 94
 Felson, L. B., AP-18, 708; UB-3, 33, 34
 Fenn, A. J. AP-24, 875
 Filho, F. C. M., AP/F-3, 649
 Filipovich, S., UB-4, 41
 Fischer, M., UB-17, 238
 Fitzwater, M. A., AP-2, 41
 Fonseca, S. B. D., AP-12, 426; AP-15,
 581
 Foo, B-Y, AP-1, 31
 Forti, R. L., AP-5, 166
 Frangos, P. V., UB-15, 185
 Fung, A. K., UB-5, 58

 Galindo-Israel, V., AP-5, 143
 Garg, R. AP-15, 584
 Gasiewski, A. J., AP/F-3, 648
 Gee, W., AP-6, 197
 Gera, A., AP-24, 902
 Geren, P., AP-24, 871
 Getsinger, W. J., UB-6, 62

- Ghione, G., UB-13, 167
 Ghobrial, S. I., AP/F-3, 633
 Giarola, A. J., AP-3, 78; AP-12, 426;
 AP-15, 581
 Glaser, P. E., AP-10, 337, 338
 Go, J., UA-1, 225
 Goldhirsch, J., UF-2, 142, 143
 Goto, N., AP-14, 527
 Graglia, R. D., AP-11, 367, UB-7, 69;
 UB-10, 117
 Grant, J. B., UB-71; UB-13; 161; UB-14,
 176
 Gross, F., AP-22, 849
 Gu, Q., UB-11, 131
 Gucho, S., AP-19, 753
 Guiravo, F. O., UF-4, 203
 Gunasekaran, N., AP-16, 623
 Gupta, K. C., UB-6, 64
 Gupta, S. C., UB-14, 178
 Gurrola, E. M., UB-2, 18
 Gutwein, T. A., AP-5, 135
- Habashy, T. M., UB-15, 186, 190
 Hamid, M., AP-4, 227; UB-4, 44
 Han, C. C., AP-5, 151
 Hanli, W., AP-16, 627
 Hannan, P. W., AP-25, 917
 Hansen, J. E., AP-17, 682
 Hara, Y., AP-14, 527
 Harker, K. J., UB-14, 173
 Hasebe, N., AP-20, 788
 Hasselmann, F. J. V., AP-9, 327; AP-18,
 708
 Haupt, R. L., AP-21, 819, 823
 Havens, D. A., AP-21, 831
 Hayes, D. T., UF-4, 199
 Hayes, P., UB-9, 97
 Hazan, I., AP-17, 659
 Heath, G. E., AP-18, 697
 Heins, A. E., UB-4, 37
 Henriques, L. M. D., AP-9, 330
 Herd, J., AP-19, 729
 Herndon, D., AP-5, 135
 Herper, J. C., AP-24, 890
 Hessel, A., AP-24, 890
 Heyman, E., UB-3, 34
 Hill, D. A., UB-2, 17
 Hill, M., UF-2, 145
 Ho, K. Y., AP-8, 279
 Hoc, N. D., UB-13, 168
 Hodgson, C., AP-5, 162
 Hogg, D. C., UF-4, 203
- Howard, J., AP/F-3, 637
 Howell, W. E., AP-1, 23
 Hsiao, J. K., AP-13, 471
 Huang, J., AP-8, 271
 Huang, Y. N., UF-1, 109
 Huang, X. Q., UB-17, 233
 Huddleston, P. L., UB-17, 236
 Hung, C. C., AP-9, 314
 Hurst, M. P., AP-7, 231
 Hwang, Y., AP-5, 151
 Hwang, Y-Y, AP-24, 906
 Hwu, S., UB-8, 83
 Ikuno, H., UB-3, 33
 Imbriale, W. A., AP-5, 135, 143; AP-20,
 767
 Imrich, D. M., UF-4, 195
 Inomata, H., AP/F-3, 650
 Ishimaru, A., AP-24, 801, UF-1, 101
 Iskander, M. F., AP-11, 363
 Ismail, N. H., AP-4, 117
 Itoh, T., UB-6, 61
 Ittipiboon, A., AP-15, 573
 Iwata, R., AP-25, 933
 Izadian, J. S., UB-16, 207
 Jackson, D. R., AP-15, 563
 Jaggard, D. L., UB-15, 185
 Jain, R. K., UB-14, 178
 Jakobsen, K., AP-16, 616
 Jambrina, J. L. F., UB-14, 177
 James, B., UB-15, 188
 Jamnejad, V., AP-9, 309; AP-11, 380;
 UF-4, 197
 Jayasuriya, D. A. K., AP/F-3, 649
 Jin, Y. Q., UB-5, 52
 Johnson, W. A., UB-13, 162; UB-14,
 174, 176
 Johnson, T. W., AP-22, 845
 Jong, H. Y., AP-9, 305
 Jørgensen, R., AP-20, 792
 Josefsson, L., AP-3, 174
 Josties, F. J., UF-4, 196
 Joy, E. B., UA-1, 217
 Ju-Liang, C., AP-3, 90
 Jull, E. V., AP-2, 45
 Jurgens, T. G., UB-8, 81
- Kagoshima, K., AP-13, 498
 Kanda, M., UB-3, 26; UA-I, 218
 Kang, Y., AP-12, 401
 Karunaratne, G., UB-16, 208
 Kastner, R., AP-17, 659; AP-25, 925
 Katagi, T., AP-14, 523

- Katehi, P. B., AP-15, 566; UB-11, 128
 Kawakami, H., AP-3, 82
 Keenan, M. D., AP-22, 841
 Kennaugh, E. M., UB-17, 229, 230
 Kerwin, E. M., AP-10, 341
 Kesler, J., AP-21, 803
 Kesler, S. B., AP-21, 803
 Khounsary, A. M., UB-5, 51
 Kezhong, Y., AP-16, 627
 Kiang, J. F., UB-14, 175
 Kildal, P. S., AP-16, 616; AP-20, 784
 King, H. E., AP-5, 131
 King, J. K., UB-1, 5
 King, R. J., UB-15, 183
 King, R. W. P., AP-4, 109; UB-9, 89,
 90
 Kishk, A. A., AP-16, 612
 Klapisz, C., UF-4, 200
 Klock, P., AP-11, 355
 Ko, W. L., UB-12, 154
 Kobayashi, K., AP-9, 937; AP-25, 937
 Kojima, T., AP-18, 716
 Kominami, M., AP-15, 559
 Kong, J. A., UF-1, 103; UB-3, 25; UB-5,
 49, 52; UB-14, 175
 Kongyu, F., AP-12, 421
 Koizu, T., AP/F-3, 650
 Kremer, M. A., UF-2, 138
 Krichevsky, V., UB-2, 14
 Krowne, C. M., AP-15, 569; AP-18, 693
 Krug, J., AP-19, 749
 Kuester, N. A., King Session, 445
 Kumar, A., AP-6, 193; AP-13, 482;
 UB-2, 20; UA-I, 223
 Kumar, H., AP-F-3, 654
 Kumar, G., AP-15, 573
 Kunz, K. S., UB-8, 79
- Lacourse, J., King, 455
 Lam, P. T., AP-6, 197; AP-9, 318;
 UB-4, 42
 Lamendsdorf, D., King Session, 434
 Lammers, U. H. W., UF-4, 199
 Lampe, R., AP-11, 355
 Lang, R. C., AP-9, 318; AP-11, 385;
 AP-25, 921
 Lang, R. H., UB-10, 119
 Langenberg, K. J., UB-17, 238
 Lary, T. L., UB-17, 235
 Larsen, F. H., AP-17, 682, 686
 Lau, S. K., AP-21, 827
 Lavergnat, J., UF-4, 200
- Lavi, L., AP-17, 659
 Laxpati, R., AP-14, 519
 Lee, B. S., AP-5, 147
 Lee, H. M., AP-11, 372
 Lee, J. C., AP-20, 771
 Lee, J. K., UF-1, 103
 Lee, K. F., AP-8, 279, 283
 Lee, K. M., AP-24, 886
 Lee, S. W., AP-6, 197; AP-9, 318, 323;
 UB-4, 42; UB-7, 73
 Lee, T-H., AP-9, 297
 Leeper, W. UB-8, 84
 Lemanczyk, J. H., AP-17, 682, 686
 Lempkowski, R. M., King Session;
 UAI-219
 Lennon, J. F., UB-5, 56
 Leone, G., AP-17, 678, AP-25, 945
 Le Roux, E., AP-16, 620
 Lesselier, D., UF-1, 101
 Leuven, K. U., AP-19, 745
 Le Vine, D. M., UB-10, 119
 Li, H. J., AP-24, 906
 Liepa, V. V. UB-3, 31; UA-I, 225
 Lin, C. C., AP-1, 7; UB-8, 77
 Lin, J. L., VB-10, 116
 Lin, S. H., UF-4, 198
 Lin, Y. L., UB-11, 127
 Lindell, I. V., UB-1, 7, 8
 Ling, H., AP-6, 197
 Link, J. N., AP-22, 845
 Litva, J., AP-21, 799
 Lo, Y. T., AP-8, 259; AP-15, 551;
 AP-20, 763; UB-11, 125
 Long, S. A., AP-8, 263
 Love, A. W., AP-9, 305
 Lucier, M., AP-5, 135
 Lytle, R. J., UB-1, 5
- Magin, R. L., AP-6, 197
 Mailloux, R. J., AP-14, 511
 Malaga, A., AP-2, 48
 Mallick, A. K., UB-11, 133
 Manning, R. M., AP/F-3, 642
 Manara, G., AP-7, 215; AP-12, 409
 Mandour, I. A., AP-4, 117
 Mano, S., AP-14, 523
 Manson, A. C., UB-17, 231
 Markhefko, R. J., AP-7, 219
 Marietta, M., AP-9, 305
 Marr, R. A., UF-4, 199
 Martin, A. Q., UB-9, 95
 Matsakis, D. N., UF-4, 196

Maybell, M. J., AP-24, 894
 Mayer, K., UB-17, 238
 Mayes, P., AP-11, 355
 McGahan, R. V., UB-10, 113
 McIntosh, R. E., AP-12, 401
 McIsaac, P. R., UB-7, 72
 McNamara, D. A. AP-6, 173
 Meckelburg, H. J., UB-13, 163
 Medgyesi-Mitschang, L. N., UB-4, 43;
 UB-8, 78
 Mei, K. K., AP-1, 7; UB-8, 77
 Mengyun, Z., AP-8, 287
 Merchant, B., UB-13, 165
 Michaeli, A., UB-4, 46
 Michalski, K. A., UB-9, 93; UB-16, 208
 Mieras, H., UB-3, 29
 Mikawa, T., AP-6, 177
 Miller, E. K., UB-1, 5; UB-17, 234
 Miller, G. E., AP-8, 275; AP-24, 871
 Miller, R., UF-2, 145
 Mittra, R., AP-7, 231; AP-11, 351, 359,
 385; AP-25, 913, 921, 925; UB-10,
 121; UB-12, 154; UB-15, 190; UB-16,
 210
 Moffatt, D. L., UB-17, 229, 230
 Mohanakrishnan, G., King Session, 455
 Montgomery, J. P., UB-12, 155
 Montgomery, N. W., AP-8, 255
 Moody, M., AP-5, 162
 Morgan, M. A., UB-3, 30; UB-17, 235
 Morris, M. E., AP-12, 397, UB-2, 18
 Moser, P. J., UB-13, 165
 Murray, R. R., UF-2, 144
 Nagi, A., UB-13, 165
 Nair, N. V., UB-11, 133
 Nakamura, K., AP/F-3, 650
 Nakamura, M. M., AP-6, 189
 Nakano, H., AP-6, 177; AP-12, 413, 417
 Nespor, J. D., AP-2, 37
 Nevels, R. D., UB-1, 4; UB-14, 171
 Newman, E. H., UB-11, 126; UB-13, 159
 Newton, J. M., AP-22, 841
 Niblack, W., King Session, 455
 Niver, E., UB-1, 6
 Norris, A. W., UF-2, 144
 Numazaki, T., AP-14, 523
 Nygren, E., AP-5, 158
 Nyquist, D. P., AP-1, 15; UB-7, 70

 O'Brien, M. J., AP-13, 467
 Ogura, H., UB-5, 54; UB-6, 54
 Ohta, H. A., AP-11, 385; AP-25, 921

 Oliner, A. A., AP-6, 181
 Olsen, R. G., UB-9, 96
 Olson, S. C., AP-11, 363
 Olson, K. E., UB-15, 185
 Olver, A. D., AP-13, 490
 Onoe, M., AP-20, 788
 Orefice, M., UB-13, 167
 Orr, R. D., UA-1, 218
 Orta, R., UB-10, 120
 Osepchuk, J. M., AP-10, 343
 Osland, P., King Session, 459
 Ott, R. H., AP-24, 882
 Overfelt, P. L., AP-6, 201
 Overly, M. M., UB-1, 4

 Paknys, J. R. J., UB-4, 40
 Panicalli, A. R., AP-6, 189; AP-9, 330
 Papa, R. J., UB-5, 56
 Papanicolopolulos, C., AP-22, 837; AP-23,
 859
 Papas, C. H., AP-14, 543
 Parad, L. I., AP-4, 97
 Park, P. K., AP-3, 62, AP-12, 393
 Parl, S., AP-2, 48
 Patel, M. R., AP-6, 205
 Pathak, P. H., AP-7, 238, UB-4, 39
 Pavlasek, T. J. F., UB-16, 213
 Pearson, L. W., UB-8, 83; UB-9, 94
 Pedersen, J. F., AP-25, 917
 Pelosi, G., AP-7, 215; AP-12, 409
 Peng, S. T., AP-6, 181; UB-13, 166
 Peng, T., UB-13, 166
 Pennock, S., UB-3, 31
 Pereira, L. C. P., AP-9, 327; AP-18, 708
 Perez, M. F. C., UB-14, 177
 Perlmutter, P., AP-15, 577
 Perrone, A., AP-5, 166
 Peters, L., UB-9, 97; UB-10, 115
 Peterson, A. F., AP-11, 351
 Pflug, D. R., AP-19, 733
 Pierri, R., AP-17, 678; AP-25, 945
 Plimpton, G., AP-6, 209
 Poe, G. D., UB-3, 28; UB-17, 234
 Pokuls, R., UB-16, 213
 Popovich, B., AP-9, 305
 Porgorzelski, R. J., UB-13, 160; UB-16,
 212
 Pozar, D. M., AP-12, 401; AP-15, 559;
 AP-19, 729, 737
 Pratt, T., UF-4, 195
 Puri, N. N., AP-12, 389
 Putnam, J. M., UB-8, 78

Raab, F. H., AP-4, 125
 Raghavan, K., AP-16, 623
 Rahmat-Samii, Y., AP-5, 143; AP-9, 323;
 UB-15, 187
 Rammos, E., AP-24, 898
 Rao, J. B. L., AP-20, 775
 Rao, K. S., AP-13, 478; AP-16, 612
 Rao, T. C. K., AP-18, 704; UB-1, 3
 Rappaport, C. M., AP-16, 608
 Ray, S., UB-16, 210
 Rengarajan, S., AP-19, 741
 Reynolds, D. K., AP-3, 70
 Riblet, G., UA-1, 220
 Richards, W. F., AP-8, 259, 263
 Riley, D. J., UB-5, 53
 Rirong, Z., AP-16, 627
 Roederer, A. G., AP-20, 792
 Rogers, J. R., AP-11, 347
 Rong-Hong, J., AP-3, 90
 Rotman, W., AP-20, 771
 Rothwell, E. J., AP-1, 15; UB-15, 189
 Rouseff, D., UB-9, 96
 Row, R. V., King Session, 437
 Rowland, J. B., UA-1, 217
 Rowland, J. R., UF-2, 142, 145
 Rubin, B. J., UB-16, 209
 Rudduck, R. C., AP-9, 293, 297
 Rusch, W. V. T., AP-20, 759; UB-13,
 160
 Ryan, Jr., C. E., AP-22, 837; AP-23, 859

 Saatchi, S. S., UB-17, 237
 Samada, Y., AP-12, 417
 Sandler, S., King Session, 460
 Santilli, D., UB-13, 167
 Sanyal, S., AP-7, 242
 Sarkar, T., UB-3, 32; UB-12, 149, 153;
 UB-14, 172
 Sata, G., AP-3, 82
 Sato, I., AP-25, 933
 Savini, D., AP-25, 929
 Scales, W. A., UF-4, 195
 Schaubert, D. H., AP-12, 401; AP-15,
 559; AP-19, 737
 Schennum, G. H., AP-5, 158; AP-16, 604
 Schneider, A., UB-10, 119
 Schrote, M. R., UB-13, 159
 Schultz, C., King Session, 459
 Schuman, H. K., AP-19, 733
 Schwerdtfeger, R., AP-16, 599
 Schwering, F. K., AP-6, 181; AP-12,
 389; UF-1, 102

 Scott, L. D., AP-4, 113
 Sebak, A. A., AP-1, 11; AP-3, 55;
 AP-18, 701; UB-16, 211
 Sega, R. M., UA-1, 224
 Sen, B., AP-20, 780
 Sengupta, D. L., AP-8, 267
 Senior, T. B. A., UB-3, 38
 Setty, P. N. R., UF-2, 137
 Sezginer, A., UB-3, 25; UB-8, 82
 Shafai, L., AP-1, 11; AP-3, 55; AP-13,
 478; AP-15, 573; AP-16, 612; AP-18,
 701; UB-11, 127; UB-16, 211
 Sharma, A. K., AP-11, 376
 Sharma, O. P., AP/F-3, 654
 Shelton, J. P., AP-14, 519
 Shen, L. C., King Session, 447
 Shiau, M. J., AP-6, 181
 Shieh, H. C., UF-2, 140
 Shih, Y. C., UB-6, 65
 Shimabukuro, F. I., F-4, 201
 Shi-Ming, L., AP-14, 531, 535
 Shin, R. T., UB-5, 49
 Shirai, H., UB-3, 34
 Shore, R. A., AP-13, 467; AP-21, 823;
 UB-2, 15
 Shtrikman, S., AP-15, 577
 Sicaro, F., UF-1, 106
 Siddiqi, S., AP-5, 147
 Singh, R., UF-2, 137
 Sivaprasad, K., King Session, 455
 Slaterbeck, M. E., AP-3, 62
 Sletten, C. J., AP-13, 474; UB-2, 13
 Smith, G. S., King Session, 451
 Smith, M. S., AP-12, 405
 Smith, T. M., AP-16, 595, 604
 Smithmeyer, P., AP-3, 70
 Soares, A. J. M., AP-15, 581
 Sockell, M. E., UB-13, 168
 Solomini, D., UF-2, 141
 Sorbello, R. M., AP-8, 251; King
 Session, 441
 Sorrentino, R., UB-6, 63
 Souza, R. F., AP-3, 78
 Speake, T. C., AP-14, 507
 Sreenivasan, A., UB-14, 178
 Srikanth, S., AP-7, 238
 Srivastava, S. K., UB-5, 55
 Staelin, D. H., UB-15, 184
 Steinberg, B. D., UB-14, 179
 Stern, G. J., AP-14, 515
 Sterns, W. G., AP-15, 555
 Steyskal, H., UB-2, 15

- Stone, W. R., UB-12, 150
 Stutzman, W. L., AP/F-3, 655; UF-4, 195
 Sultan, M. F., AP-11, 351, 359; UB-10, 121
 Sultan, N., AP-5, 162; UB-10, 121
 Sun, L. T., AP-22, 841
 Sun, N., UB-12, 156
 Sylvain, M., UF-4, 200
- Taflove, A., UB-8, 80, 81
 Tai, C. T., King Session, 458
 Takahashu, N., UB-5, 54
 Tamagawa, S., AP-25, 933
 Tang, R., AP-24, 886
 Tascone, R., UB-10, 120
 Taylor, R. L., UB-5, 56
 Tehan, J. E., UB-11, 126
 Terzuoli, A. J., AP-21, 831
 Tetu, M., UA-1, 221
 Tew, M., UB-4, 41
 Thai, V. T., AP-21, 827
 Tiberio, R., AP-7, 215; AP-12, 409
 Thomas, M. E., UF-1, 108
 Tomasic, B., AP-24, 890
 Tremblay, P., UA-1, 221
 Treves, D., AP-15, 577
 Tripp, V. K., AP-18, 712; AP-22, 837
 Tsang, L., UF-1, 104
 Tsao, C., AP-5, 151
 Tsao, J., UB-14, 179
 Tseng, F. I., UB-12, 149
 Tsukiji, T., AP-3, 86
 Tulintseff, A., AP-8, 251
 Tun, S. M., AP-13, 486, 494
- Überall, H., AP-1, 23; UB-13, 165
 Umashankar, K. R., UB-8, 80, 81
 Uslenghi, P. L. E., AP-7, 235; AP-11, 367; UB-2, 16; UB-7, 69; UB-10, 117
 Uzunoglu, N. K., UB-11, 130
- Van Blaricum, M. L., UB-17, 235
 Van De Capelle, A., AP-19, 745
 Van Lil, E., AP-19, 745
 Venkatachalam, P. A., AP-16, 623
 Villeneuve, B., UA-1, 221
 Vogel, W. J., UF-4, 202
 Voglis, E., AP-13, 490
 Volakis, J., UB-10, 115
 Vu, T. B., AP-21, 811, 827
- Walsh, J., UB-5, 55
 Walton, E. K., UB-17, 232
 Wang, B. F., AP-15, 551
 Wang, O. S. Y., UB-4, 43
 Wang, J. J. H., AP-22, 837, 841
 Wang, N., AP-18, 710; UB-4, 40; UB-17, 229, 230
 Warne, L. K., UB-10, 118
 Webb, L., AP-1, 19
 Weed, J. C., AP-14, 507
 Wegrowicz, L. A., UB-16, 213
 Weill, A., UF-4, 200
 Weinfurter, G., UB-17, 238
 Welsh, B. M., AP-17, 666
 Wen, B., UF-1, 104
 Wen-Siang, AP-3, 90
 Westwater, E. R., UF-4, 203
 Whelpton, J., AP-5, 162
 Whitman, G. M., UB-1, 6; UF-1, 102
 Williams, W. F., AP-20, 767
 Willwerth, F. G., AP-24, 875
 Wilton, D. R., UB-14, 176
 Wittmann, R. C., AP-17, 674
 Wolkoff, E. A., UB-2, 19
 Wokurka, J., AP-25, 941
 Wolfson, R. I., AP-15, 555
 Wong, J. L., AP-5, 131
 Wong, N. S., AP-24, 886
 Woo, V., AP-3, 66
 Wright, S. M., UB-11, 125
 Wu, R. B., AP-18, 724
 Wu, T. K., UB-12, 151
 Wu, T. T., AP-12, 397; King Session, 459
- Xin, L. Z., AP-14, 539
- Yaghjian, A. D., AP-17, 670; UB-10, 113
 Yamada, Y., AP-13, 498
 Yamane, T., AP-12, 417
 Yamasaki, M., AP-3, 86
 Yamauchi, J., AP-6, 177; AP-12, 417
 Yang, C. W., UB-15, 188
 Yang, S. I., UB-4, 38
 Yasumoto, K., AP-18, 720
 Yeh, C., UF-1, 101
 Yon, K. M., AP/F-3, 655
 Yoo, K. B., UB-13, 165
 Young, J. D., UB-8, 84
 Yu, C. L., UB-10, 114

Zaghloul, A. I., AP-16, 608; King
Session, 441
Zanger, P., UB-17, 238
Zarghamee, N. S., AP-20, 777
Zich, R., UB-10, 120; UB-13, 167
Zimmer, R., UB-13, 164
Ziolkowski, R. W., UB-7, 71; UB-13,
161, 162; UB-14, 174
Zucker, F. J., King Session, 433

1984 IEEE/AP-S and URSI Technical Program

	ROOM	MONDAY, JUNE 25	TUESDAY, JUNE 26	WEDNESDAY, JUNE 27	THURSDAY, JUNE 28	FRIDAY, JUNE 29
AFTERNOON	ESSEX NORTH WEST	URSI/B-3 TRANSIENTS Page 23	APS-11 NUMERICAL METHODS Page 345	URSI/B-12 NUMERICAL METHODS I Page 147	URSI/B-16 NUMERICAL METHODS III Page 205	
	ESSEX NORTH CENTER	URSI/B-4 DIFFRACTION & ASYMPTOTIC TECHNIQUES Page 35	URSI/B-10 SCATTERING Page 111	URSI/B-13 ELECTROMAGNETIC THEORY Page 157	APS-22/23 HALF SESSION RADAR CROSS SECTION METHODS HALF SESSION ANTENNA PATTERNS & POLARIZATION PROPERTIES Page 835/853	
	ESSEX NORTH EAST	URSI/B-5 RANDOM MEDIA PROPAGATION AND SCATTERING Page 47	APS-12 ANTENNA THEORY Page 387	APS-14 PATTERN ANALYSIS AND SYNTHESIS Page 505	URSI/A-1 MEASUREMENTS FOR ANTENNAS Page 215	
	ESSEX SOUTH	APS-4 SURFACE AND UNDER- GROUND ANTENNAS AND WAVES Page 95	URSI/B-11 MICROSTRIP AND STRIPLINE ANTENNAS AND STRUCTURES Page 123	APS-15 MICROSTRIP INTEGRATED CIRCUIT ANTENNAS II Page 549	APS-24 PHASED ARRAYS Page 869	AMTA NEAR FIELD MEASUREMENT TECHNIQUES WORKSHOP
	ESSEX CENTER	APS-5 AIRCRAFT AND SPACECRAFT ANTENNAS Page 129	APS-URSI/B SESSION TO HONOR PROF R W P KING Page 431	APS-16 ANTENNA FEEDS Page 589	APS-25 REFLECTOR ANTENNAS IV Page 911	
	ST. GEORGE "A", "B"	URSI/B-6/7 CAD-ORIENTED FIELD AND NETWORK ANALYSIS GUIDED WAVES Page 67	URSI/F-2 MODELLING AND MEASUREMENT OF PROPAGATION EFFECTS Page 135	URSI/F-3/AP-S EFFECTS OF THE ATMOSPHERE ON PROPAGATION Page 631	URSI/B-17 IMAGE IDENTIFICATION Page 227	
	ST. GEORGE "C", "D"	APS-6 SPECIAL TOPICS IN ANTENNAS Page 171	APS-13 REFLECTOR ANTENNAS II Page 461	APS-17 ANTENNA MEASUREMENTS Page 657		

