

**National Academies of Science and Engineering
National Research Council
of the
United States of America**

**UNITED STATES NATIONAL COMMITTEE
International Union of Radio Science**

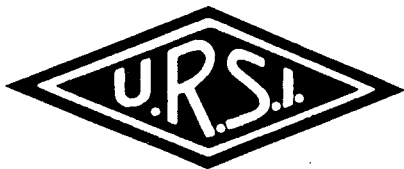

National Radio Science Meeting

May 23-26, 1983

**Sponsored by USNC/URSI
held jointly with
International Symposium of
Antennas and Propagation Society
Institute of Electrical and Electronics Engineers
University of Houston
Houston, Texas
U.S.A.**

NOTE:

Programs and Abstracts of the USNC/URSI Meetings are available from:

USNC/URSI
National Academy of Sciences
2101 Constitution Avenue, N.W.
Washington, DC 20418

at \$2 for meetings prior to 1970, \$3 for 1971-75 meetings, and \$5 for 1976-83 meetings.

The full papers are not published in any collected format; requests for them should be addressed to the authors who may have them published on their own initiative. Please note that these meetings are national. They are not organized by the International Union, nor are the programs available from the International Secretariat.



On behalf of the Steering Committee, I am pleased to welcome you to Houston for the 1983 IEEE International Symposium on Antennas and Propagation and National Radio Science Meeting.

A broad spectrum of regular technical sessions have been organized which we hope will facilitate the exchange of information among the participants during the week of the conference. Several special technical sessions have been formed emphasizing topics of particular interest in the Houston area. Under the general topic of "Electromagnetic Methods of Geophysical Exploration and Detection" sessions have been organized on Exploration for Petroleum and Minerals, Lithosphere Exploration, Tunnel Detection, and Well Logging. While under the general topic of "Antennas in Space", sessions will be presented on Spacecraft Antennas and Satellite Antennas. A Plenary Session, jointly sponsored by AP-S and URSL, will occupy Wednesday morning and will offer four invited papers on topics of current interest.

The social portion of the program has been designed to provide the visitor the opportunity for experiences somewhat unique to the Houston area. Tours are planned to the NASA-Johnson Spacecraft Center, Houston Museums, the Houston Ship Channel, the Galleria shopping area, and the University of Houston itself. The highlight of the social program is the Tuesday night awards banquet consisting of a Texas-style barbecue combined with a private professional rodeo at the Houston Farm and Ranch Club.

I would like to give my thanks to the members of the Steering Committee and the Technical Program Committee, along with the Program Directors for their contributions to the success of the meeting. Special recognition should be given to Liang Shen and Bill Richards for their acceptance of a large number of tasks usually spread over many steering committee members. Lastly, I would like to express our gratitude to the support provided by the Department of Electrical Engineering at the University of Houston.

I hope your stay in Houston is pleasant for you personally, and that your participation in the conference is professionally rewarding.

Sincerely,

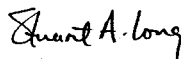
A handwritten signature in cursive script that reads "Stuart A. Long".

Stuart A. Long
Chairman, Steering Committee

MEMBERSHIP

United States National Committee

INTERNATIONAL UNION OF RADIO SCIENCE

Chairman:

Prof. Thomas B.A. Senior *

Vice Chairman:

Prof. Robert K. Crane *

Secretary:

Dr. Thomas E. VanZandt *

Immediate Past Chairman:

Dr. C. Gordon Little *

Members Representing Societies, Groups and Institutes:

American Geophysical Union	Dr. Christopher T. Russell
Bioelectromagnetics Society	Dr. James C. Lin
Institute of Electrical & Electronic Engineering	
IEEE Antennas & Propagation Society	Dr. Alan W. Love
IEEE Communications Society	Prof. Raymond Pickholtz
IEEE Electromagnetics Compatibility Society	
IEEE Information Theory Group	
IEEE Microwave Theory & Techniques Society	
IEEE Quantum Electronics Society	Prof. Herman A. Haus
Optical Society of America	Dr. Steven F. Clifford

Liaison Representative from Government Agencies:

National Telecommunications & Information Administration	Dr. Douglass D. Crombie
National Science Foundation	Dr. Vernon Pankonin
Department of Commerce	
National Aeronautics & Space Administration	Dr. Erwin R. Schmerling
Federal Communications Commission	Mr. William A. Daniel
Department of Defense	Dr. George L. Salton
Department of the Army	Lt. Col. Robert Clayton, Jr.
Department of the Navy	Dr. Leo Young
Department of the Air Force	Dr. Allan C. Schell

Members-at-Large:

Dr. Sidney A. Bowhill
Dr. Juergen E. Richter
Dr. George W. Swenson, Jr.

*Members of USNC-URSI Executive Committee

Chairmen of the USNC-URSI Commissions:

Commission A	Dr. Helmut Hellwig
Commission B	Prof. Chalmers M. Butler
Commission C	Dr. Andrew J. Viterbi
Commission D	Drs. K.J. Button and A.A. Oliner
Commission E	Dr. Arthur A. Giodano
Commission F	Dr. Earl E. Gossard
Commission G	Dr. Kenneth Davies
Commission H	Dr. Robert F. Benson
Commission J	Prof. Mark A Gordon

Officers of URSI resident in the United States:
(including Honorary Presidents)

President	Prof. William E. Gordon*
Honorary President	Prof. Henry G. Booker*

Chairmen and Vice Chairmen of Commissions of URSI
resident in the United States:

Chairman of Commission C	Prof. Jack K. Wolf
Vice Chairman of Commission G	Dr. Jules Aarons

Foreign Secretary of the U.S. National Academy of Sciences	Dr. Thomas F. Malone
---	----------------------

Chairman, Office of Physical Sciences-NRC	Prof. William A. Fowler
---	-------------------------

NRC Staff Officer	Mr. Richard Y. Dow
-------------------	--------------------

Honorary Members:	Dr. Harold H. Beverage Dr. Ernst Weber
-------------------	---

*Member of USNC-URSI Executive Committee

DESCRIPTION OF THE INTERNATIONAL UNION OF RADIO SCIENCE

The International Union of Radio Science is one of 18 world scientific unions organized under the International Council of Scientific Unions (ICSU). It is commonly designated as URSI (from its French Name, Union Radio Scientifique Internationale). Its aims are (1) to promote the scientific study of radio communications, (2) to aid and organize radio research requiring cooperation on an international scale and to encourage the discussion and publication of the results, (3) to facilitate agreement upon common methods of measurement and the standardization of measuring instruments, and (4) to stimulate and to coordinate studies of the scientific aspects of telecommunications using electromagnetic waves, guided and unguided. The International Union itself is an organizational framework to aid in promoting these objectives. The actual technical work is largely done by the National Committee in the various countries.

The officers of the International Union are:

President:	W.E. Gordon (USA)
Past President:	W.N. Christiansen (Australia)
Vice Presidents:	A.L. Cullen (UK) A.P. Mitra (India) S. Okamura (Japan) A. Smolinski (Poland)
Secretary-General:	J. Van Bladel (Belgium)
Honorary Presidents:	G. Beynon (UK) H.G. Booker (USA) W. Dieminger (West Germany) I. Koga (Japan) J.A. Ratcliffe (UK)

The Secretary-General's office and the headquarters of the organization are located at Avenue Albert Lancaster 32, B-1180 Brussels, Belgium. The Union is supported by contribution (dues) from 38 member countries. Additional funds for symposia and other scientific activities of the Union are provided by ICSU from contributions received for this purpose from UNESCO.

The International Union, as of the XXth General Assembly held in Washington, D.C., in August 1981, has nine bodies called Commissions for centralizing studies in the principal technical fields. The names of the Commissions and their chairmen follow.

- A. Electromagnetic Metrology
V. Kose (FRG)
- B. Fields and Waves
H.G. Unger (FRG)
- C. Signals and Systems
J.K. Wolf (USA)
- D. Electronic and Optical Devices and Applications
J. Le Mezec (France)
- E. Electromagnetic Noise and Interference
S. Lundquist (Sweden)
- F. Remote Sensing and Wave Propagation
D. Gjessing (Norway)
- G. Ionospheric Radio and Propagation
P. Bauer (France)
- H. Waves in Plasmas
M. Petit (France)
- J. Radio Astronomy
V. Radhakrishnan (India)

Every three years the International Union holds a meeting called the General Assembly, the next is the XXIst, to be held in Florence, Italy, in August/September, 1984. The Secretariat prepares and distributes the Proceedings of these General Assemblies. The International Union arranges international symposia on specific subjects pertaining to the work of one or several Commissions and also cooperates with other Unions in international symposia on subjects of joint interest.

Radio is unique among the fields of scientific work in having a specific adaptability to large-scale international research programs, since many of the phenomena that must be studied are world-wide in extent and yet are in a measure subject to control by experimenters. Exploration of space and the extension of scientific observations to the space environment are dependent on radio for their research. One branch, radio astronomy, involves cosmic phenomena. URSI thus has a distinct field of usefulness in furnishing a meeting ground for the numerous workers in the manifold aspects of radio research; its meetings and committee activities furnish valuable means of promoting research through exchange of ideas.

1983 National Radio Science Meeting

Steering Committee

Stuart A. Long, Chair

Liang C. Shen, Technical Program
William F. Richards, Finance
John C. Wolfe, Publications
Stuart A. Long, Local Arrangements
William E. Gordon, URSI Liaison

Technical Program Committee

Liang C. Shen, Chairman

Chalmers M. Butler
H. Dean Cubley
William E. Gordon
Tim Hawe
Tatsuo Itoh
C.M. Krowne
S.W. Lee
Stuart A. Long
Robert J. Mailloux
Robert D. Nevels
William F. Richards
W. Ross Stone
Leung Tsang

Program Directors

Judy M. Long - Tours
Gerhard F. Paskusz - Institutional facilities
Mark W. McAllister - Technical session coordinator

TABLE OF CONTENTS

URSI	pages 1-151
Author Index	pages 152-154

URSI/B-1-1
ANTENNAS AND SCATTERERS NEAR
INTERFACES

Auditorium 2 - AH
Monday 8:30 - 12:00

CHAIRMAN: Robert G. Olsen
Department of Electrical Engineering
Washington State University
Pullman, WA 99164

1. (8:30) *RADIATION OF WIRE ANTENNAS IN THE PRESENCE OF AN INTERFACE*, R. Tiberio, G. Pelosi, G. Manara, University of Florence, Istituto di Elettronica, Florence, Italy
2. (8:50) *CURRENT INDUCED ON CYLINDERS NEAR MEDIA INTERFACES*, Xiao-Bang Xu, Chalmers M. Butler, University of Mississippi, Dept. of Electrical Engineering, University, MS 38677
3. (9:10) *ANALYSIS OF COUPLED CONDUCTING STRIPS EMBEDDED IN A DIELECTRIC SLAB*, Krzysztof A. Michalski, Chalmers M. Butler, University of Mississippi, Dept. of Electrical Engineering, University, MS 38677
4. (9:30) *INTERFACIAL POLARIZATION AND INDUCED EDDY CURRENTS IN SUB-SURFACE CONDUCTORS*, James R. Wait, Jeffery T. Williams, University of Arizona, Dept. of Elec. Engineering, Tucson, AZ 85721
5. (9:50) *THE CYLINDRICAL DIPOLE IN A DISSIPATIVE CYLINDRICALLY LAYERED MEDIUM. A SOLUTION VIA MOMENT METHOD IN THE SPECTRAL DOMAIN*, Giorgio V. Borgiotti, Institute for Defense Analyses, 1801 N. Beauregard Street, Alexandria, VA 22311
6. (10:40) *DIRECTIVE PROPERTIES OF ANTENNAS FOR TRANSMISSION INTO A MATERIAL HALF-SPACE*, Glenn S. Smith, Georgia Institute of Technology, School of Electrical Engineering, Atlanta, GA 30332
7. (11:00) *FOCUSING OF ELECTROMAGNETIC WAVES THROUGH A DIELECTRIC INTERFACE AND ITS APPLICATION IN MICROWAVE HYPERTHERMIA*, H. Ling, S. W. Lee, University of Illinois, Dept. of Elec. Eng., Urbana, IL 61801
8. (11:20) *SYNTHESIS OF FOCUSED HYPERTHERMIA APPLICATORS*, M. S. Sheshadri, Raj Mittra, University of Illinois, Electrical Engineering Dept. 1406 W. Green, Urbana, IL 61801
9. (11:40) *MAGNETOTELLURIC MEASUREMENTS OF TENSOR IMPEDANCES AT THE ELF WISCONSIN TEST FACILITY*, David H. S. Cheng, Edwin A. Wolkoff, c/o E. A. Wolkoff, Code 3411, New London Laboratory, Naval Underwater Systems Center, New London, CT 06320

RADIATION OF WIRE ANTENNAS IN THE PRESENCE OF AN INTERFACE

R.Tiberio, G.Pelosi, G.Manara

Istituto di Elettronica, University of Florence

Florence, Italy

A hybrid technique which combines the Method of Moments (MM) with ray methods, is employed to analyze the radiation of wire antennas in the presence of an interface. In applying the MM, piece-wise sinusoid (PWS) basis and testing functions are used. The field of each PWS dipole is represented in terms of three sources of transverse, spherical waves, which provide an exact representation for the field radiated in free space. In this paper, the basic assumption is made that a PWS current distribution can be replaced by a suitable distribution of such equivalent sources, so that the fields of these sources can be treated separately. Therefore, when a wire antenna radiates in the presence of an interface between two media, the field of each of the sources, which are used to represent the unknowns of the pertinent systems of linear equations, is reflected and transmitted at the interface by applying a standard ray-method technique. Via this procedure, the elements of the MM impedance matrix are easily modified by including reflected and transmitted field contributions, which account for the presence of the interface.

Although this approach can be rigorously justified only in the case of a plane, perfectly conducting interface, its accuracy is demonstrated in several examples. In particular, in calculating the field both radiated in the antenna half space and transmitted through a plane interface the numerical results are found in a very good agreement with those obtained by using the rigorous Sommerfeld integral representation, even when the antenna is placed very close to the surface.

This approach, which employs the ray method to calculate reflected and transmitted field contributions, appears to be useful to treat the cases of curved interfaces and of plane, stratified media, when combined also with a hybrid ray-mode method.

CURRENT INDUCED ON CYLINDERS NEAR MEDIA INTERFACES

Xu Xiao-Bang and Chalmers M. Butler
Department of Electrical Engineering
University of Mississippi
University, MS 38677

In this paper are presented the results of the initial phases of a study of the current induced on conducting cylinders which reside either above or below the interface between two half spaces and which are illuminated by an incident plane wave or by a line source. The medium in the upper half space is taken to be lossless while that in the lower region may be either lossless or lossy. The cylinders are of infinite extent with axes parallel to the media interface, and various cross sections, e.g., circular, rectangular, elliptic, are considered. Both transverse electric and transverse magnetic two-dimensional excitation are admitted. An integral equation for the currents is formulated and a numerical method for solving this equation is outlined. The Sommerfeld integrals in the integral equations are evaluated by different schemes and the effectiveness of the schemes is discussed. In addition integral equations are derived for coupled, parallel cylinders which are near the interface, and a procedure for solving them is presented. Data are presented for several cases of interest, including those in which the cylinders are on the same side of the interface as well as on opposite sides.

ANALYSIS OF COUPLED CONDUCTING STRIPS EMBEDDED IN
 A DIELECTRIC SLAB: Krzysztof A. Michalski and
 Chalmers M. Butler, Department of Electrical Engi-
 neering, University of Mississippi, University, MS
 38677

Results are presented of a study of coupled perfectly electrically conducting (PEC) strips embedded in a dielectric slab (see the figure below) and excited by either a plane wave incident in the upper half-space or by a surface wave propagating in the slab. Coupled integral equations for the current density induced on the two strips are formulated and solved numerically by the method of moments. Care is given to accurate and efficient evaluation of the Sommerfeld-type integrals which are incorporated in the kernels of these equations. Current distributions for several cases of interest are presented and interpreted physically.

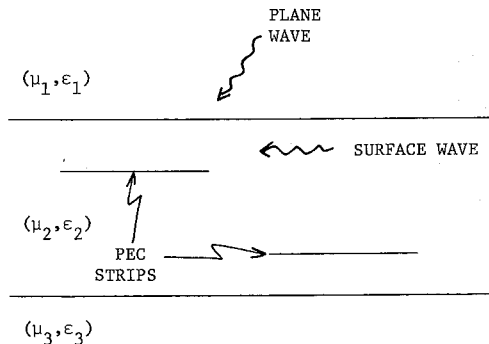

INTERFACIAL POLARIZATION AND INDUCED EDDY CURRENTS IN SUB-SURFACE CONDUCTORS

James R. Wait and Jeffery T. Williams
Department of Electrical Engineering
University of Arizona, Tucson, AZ 85721

We present a basic formulation of the mutual coupling between grounded circuits of finite length on a homogeneous half space model of the earth that contains a vertical conductor. This is intended to be a model to represent the spurious response of a metal well casing or vertical pipe when a four electrode scheme is employed for geophysical exploration of mineral resources. Both interfacial polarization and induced eddy currents in the vertical metal structure are accounted for.

The analysis is simplified without loss of useful generality by neglecting displacement currents in the air which restricts attention to distances that are small compared with the free space wavelength. Also the vertical structure is idealized as a slender cylinder of infinite depth that outcrops the surface. The electrochemical influence is characterized by an interface impedance that relates the frequency dependent voltage drop to the normal current flow. The eddy currents in the metal structure are included in the general boundary condition that is applied at the outer surface. The self consistent analysis allows fully for the interaction of the induced currents in the conductive environment and the vertical metal structure.

The final result is presented in terms of the mutual impedance between grounded circuits consisting of insulated wires lying on the earth's surface. The relevance of the analysis to electrically prospecting with time varying electromagnetic fields is described. Of course, in the limit of direct current, we recover known results for the resistivity response of buried cables [J. R. Wait, *GeoElectromagnetism*, Academic Press, New York, 1982].

"THE CYLINDRICAL DIPOLE IN A DISSIPATIVE
CYLINDRICALLY LAYERED MEDIUM. A SOLUTION
VIA MOMENT METHOD IN THE SPECTRAL DOMAIN."

Giorgio V. Borgiotti
Institute for Defense Analyses
1801 N. Beauregard Street
Alexandria, Virginia 22311

The evaluation of the impedance, current and field of a cylindrical center fed dipole in a generally lossy, radially layered medium is an involved electromagnetic problem of relevance in areas as different as communication between buried antennas and diagnostic measurements. Perhaps the simplest representative example of this class of problems is the dipole antenna having an insulating jacket and surrounded by a dissipative medium. The analysis becomes relatively simple and straightforward if the appropriate spectral representation of the field is used in conjunction with the moment method. The field is represented as a superposition of cylindrical waves, whose complex amplitudes - the Fourier Transforms in the direction of the antenna axis of the field components - depend in a relatively simple way upon the antenna current distribution. The latter is found by enforcing the boundary condition for the electric tangential field on the antenna surface. The procedure is straightforward and computationally simple if the Fourier Transforms of the field and current are used, rather than the physical quantities themselves. Once the antenna current distribution has been found, the field components are obtained from their Fourier Transforms via an inverse Fourier Transformation. Numerical examples are presented.

DIRECTIVE PROPERTIES OF ANTENNAS FOR TRANSMISSION INTO A MATERIAL HALF-SPACE

Glenn S. Smith
School of Electrical Engineering
Georgia Institute of Technology
Atlanta, Georgia 30332

Abstract

The directive properties of resonant horizontal circular-loop antennas for transmission into a material half-space, such as the earth, were examined in detail in two recent papers (An and Smith, *Radio Science*, 17, 483-502, May-June 1982; Smith and An, Abstract, 1982 Spring URSI Meeting, Albuquerque, NM). This work showed that a loop in a dielectric half-space 1 could have a directive field pattern into the adjacent dielectric half-space 2; the directivity at a point directly below the loop increasing with the ratio of the permittivities ϵ_2/ϵ_1 . The maximum directivity occurs when the loop is close to the interface; the optimum height being approximately $0.1 \lambda_1$. The directive properties when the media have low dissipation were shown to be similar to those for lossless dielectric media.

In this paper the field of a general antenna over a material half-space is obtained as a spectrum of plane waves. The integrals representing the field are evaluated asymptotically to obtain the "space wave" or "geometrical optics" field of the antenna. This field is used to describe the directive properties of the antenna when the media involved have low dissipation. The interesting features that were demonstrated for the circular loop, e.g., the directive pattern and optimum height, are shown to be general properties of antennas over a material interface and are explained with simple physical arguments. Specific numerical results are presented for infinitesimal horizontal electric and magnetic dipoles when the ratio of permittivities ϵ_2/ϵ_1 for the media is both greater than and less than one.

Measured field patterns and directivities for antennas near an interface between air and fresh water are in good agreement with theory.

FOCUSING OF ELECTROMAGNETIC WAVES
THROUGH A DIELECTRIC INTERFACE
AND ITS APPLICATION IN MICROWAVE HYPERTHERMIA

H. Ling and S. W. Lee
Department of Electrical Engineering
University of Illinois
Urbana, Illinois

The focusing of electromagnetic waves from an aperture was first studied by E. Lommel in 1885 and since then has captured the attention of many researchers in the fields of optics and microwaves. In this paper we will consider a new aspect of this classical topic. Instead of dealing with a single homogeneous medium, we analyze the case when the aperture and the focal point are in two different dielectric media. This study is motivated by our attempt to use microwave energy for localized heating of embedded cancerous tumors. Clinical studies have shown that the treatment of tumors with heat, or hyperthermia, often causes tumor regression.

Our approach to the problem is first to derive the necessary aperture current phase distribution that will produce the maximum fields at the desired focal point. Then, with an arbitrarily assumed aperture current amplitude distribution, we determine the fields by the superposition of plane waves. The far field solution can be asymptotically approximated by the method of stationary phase. Finally, we calculate the ratio between the power delivered to the focal region and the incident power from the aperture. This quantity provides a good measure of the focusing capability. In this paper, we will present numerical results, as well as discuss how this information can be used as design guidelines for a focused microwave hyperthermia applicator.

SYNTHESIS OF FOCUSED HYPERTHERMIA APPLICATORS

M. S. Sheshadri and R. Mittra
Electrical Engineering Department
University of Illinois
Urbana, Illinois

Recent interest in hyperthermia treatment of cancerous tissues has prompted the investigation of various techniques for focusing microwave energy in a small region in the vicinity of the tumor without causing deleterious effects on the healthy cells and tissues surrounding it. A conventional approach to focused microwave hyperthermia entails the use of a phased array or a reflector, whose aperture distribution is chosen so as to create a near-field focal distribution in a uniform medium with a dielectric constant close to that of the body tissues. However, this approach produces a focal distribution which deviates substantially from the ideal or desired distribution. In this paper, we examine the inverse problem of determining the aperture distribution of an aperture antenna, e.g., a reflector or phased array, which would produce the best approximation of a desired distribution inside a multilayered lossy dielectric medium. The method of analysis is based on the Plane Wave Spectrum (PWS) representation, and the inverse problem is solved by inverting a transformation matrix which relates the spectral components in the fields in the focal plane to the ones in the aperture plane of the antenna. For numerical computations, the biological medium is modeled as a two-layered medium simulating muscle and fat; the extension to the multilayered case is readily possible. Once the optimal aperture distribution is obtained, a planar phased array or a combination of reflector and a phased array can be employed to produce the desired aperture distribution.

Extensive numerical studies are being conducted to determine the design parameters, e.g., the optimal frequency and required aperture size, and to assess the practical realizability of the desired aperture distribution. The question of reducing the interface mismatch via the introduction of a matching medium is also being addressed. The results of these studies will be reported in the paper.

MAGNETOTELLURIC MEASUREMENTS OF TENSOR IMPEDANCES
AT THE ELF WISCONSIN TEST FACILITY

David H. S. Cheng and Edwin A. Wolkoff
New London Laboratory
Naval Underwater Systems Center
New London, CT 06320

Early in 1982, Magnetotelluric (MT) measurements of the tensor impedances at the earth's surface were made at the U. S. Navy's extremely low frequency (ELF) Wisconsin Test Facility (WTF). The WTF is located in the Chequamegon National Forest in north-central Wisconsin, about 8 km south of the village of Clam Lake. The WTF consists of two 22.5 km quasi-orthogonal antennas (north-south, east-west), with the transmitting station at the midpoints of the antennas. Each antenna is grounded at both ends. The antenna lines are not straight. The general direction is 19°E of N for the NS antenna and 109°E of N for the EW antenna. MT measurements were taken at 31 sites with 15 each along the EW and the NS antennas at nearly equi-spaced distances and one near the midpoint.

These measurements provide the needed parameters for the prediction of the performance of the ELF antenna. We show from the reciprocity theorem that the measurements of field incident upon the earth can be used to predict the effect of the earth on fields radiated from the antenna on earth's surface. The theoretical approach involves determining the receiving pattern of a horizontal antenna at the ground surface. Estimations of the transmitting pattern from the receiving pattern are made possible for the case of an anisotropic ionosphere and an anisotropic homogeneous ground at frequencies below 100 Hz.

Computer models are developed to calculate the radiation pattern of horizontal electric dipole (HED) antennas on ground surface. The models accept the MT tensor impedance measurements and any antenna configurations. To validate the MT measurements and the models used to handle them, comparisons with the pattern and steering measurements are made. Calculations predict what we learned from the pattern measurements performed on the NS and EW antennas of the WTF that the EW antenna pattern is skewed clockwise and the NS antenna is skewed counterclockwise. They also provide a plausible explanation of the phasing anomalies of the WTF antennas. These models can be useful in the selections of antenna corridors and right of way for other possible ELF transmitter sites and to predict the performance of any combination of HED antennas.

URSI/B-1-2
TRANSIENTS

101 - AH
Monday 8:30 - 11:40

CHAIRMAN: C. L. Bennett
Sperry Research Center
Sudbury, MA 01776

1. (8:30) *S-PLANE REPRESENTATIONS FOR TRANSIENT EM SCATTERING SIGNATURES*, Michael A. Morgan, Naval Postgraduate School, Dept. of Electrical Engineering, Monterey, CA 93840, M. L. Van Blaricum, J. R. Auton, Effects Technology, Inc., Santa Barbara, CA 93111
2. (8:50) *TRANSIENT ELECTROMAGNETIC IDENTIFICATION BY NON-LINEAR LEAST SQUARES*, Dennis M. Goodman, Lawrence Livermore National Laboratory, Livermore, CA 94550, Donald G. Dudley, University of Arizona, Dept. of Electrical Engineering, Tucson, AZ 85721
3. (9:10) *THE MODELING OF THE EARLY TIME IN TRANSIENT SCATTERING RESPONSES*, J. R. Auton, General Research Corp., 5383 Hollister Ave., Santa Barbara, CA 93111
4. (9:30) *RAY-OPTIC AND SEM MODELS IN TRANSIENT IDENTIFICATION*, Donald G. Dudley, Robert Weyker, Jay Simon, University of Arizona, Dept. of Electrical Engineering, Tucson, AZ 85721
5. (9:50) *DEVELOPMENT OF A FREE-FIELD TRANSIENT SCATTERING RANGE*, Michael A. Morgan, Naval Postgraduate School, Dept. of Electrical Engineering, Monterey, CA 93940
6. (10:40) *THE TRANSIENT RESPONSE OF FINITE, OPEN, CIRCULAR CYLINDERS*, P. L. Huddleston, C. Eftimiu, McDonnell Douglas Research Laboratories, St. Louis, MO 63166
7. (11:00) *THE CRITICAL DAMPING PHENOMENON ASSOCIATED WITH TRANSIENT RESPONSE OF AN IMPEDANCE-LOADED THIN-WIRE ANTENNA*, Ahmad Hoorfar, David C. Chang, University of Colorado, Dept. of Elec. Engr., Campus Box 425, Boulder, CO 80309
8. (11:20) *ELECTROMAGNETIC PULSE PENETRATION INTO A CLOSED VOLUME THROUGH LOSSY WALLS*, Probrir K. Bondyopadhyay, New York Institute of Technology, Dept. of Elec. Engr. & Computer Science, Old Westbury, NY 11568

S-PLANE REPRESENTATIONS FOR TRANSIENT
ELECTROMAGNETIC SCATTERING SIGNATURES

Michael A. Morgan
Department of Electrical Engineering
Naval Postgraduate School
Monterey, California

Michael L. Van Blaricum, Jon R. Auton
Effects Technology, Inc.
Santa Barbara, California

Transient scattering responses for finite-sized objects have been shown to have multiple representations via the Singularity Expansion Method (SEM), (C.E. Baum, L.W. Pearson, Electromagnetics, 1, 209-228, 1981). A simple generic representation is considered in this paper which offers the potential for unique s-plane scatterer identification through the use of early as well as late-time impulse response data. This is particularly important for "low-Q" targets having highly damped eigenmodes due to either radiation and/or resistive thermal energy dissipation. In such cases only relatively small portions of the total scattered energy remain for late-times when the impulse response enters its undriven "free-response" regime.

The early-time impulse response representation considered utilizes a simple sum of time-function weighted exponentials having the same natural frequencies as in the late-time fixed residue series. These early-time weighting functions are shown to evolve in time with null initial conditions and fixed residue end-point conditions at the transition to the late-time. The relationships of this representation to those of the canonical SEM forms, which use sum of residues and entire functions, are considered. The potential utility of this description in incorporating early-time data for target identification is discussed with example computations displayed.

TRANSIENT ELECTROMAGNETIC IDENTIFICATION BY
NON-LINEAR LEAST SQUARES

Dennis M. Goodman
Lawrence Livermore National Laboratory
Livermore, CA 94550

Donald G. Dudley
Department of Electrical Engineering
University of Arizona
Tucson, AZ 85721

The linear predictor form of the difference equation model has been a popular one in electromagnetic transient identification, primarily because least squares minimization results in a linear identification procedure. Predictor algorithms have often been developed to solve the least squares problem recursively. Successful implementations of such algorithms in areas outside electromagnetics have taken advantage of large volumes of data where one can take advantage of theories involving asymptotic convergence of parameters. In the transient electromagnetic identification problem, however, the lengths of the data records are, in most cases of practical interest, too short for the asymptotic theory.

We present an identification based on an output error model rather than the predictor error model. We do non-linear least squares error minimization and develop a "batch" process algorithm. We try the algorithm first against synthetic data generated from boundary-value problem solutions. We next present some results for actual data taken on a transient range. Finally, we compare results with a recursive least squares predictor.

THE MODELING OF THE EARLY TIME IN
TRANSIENT SCATTERING RESPONSES

J. Auton
General Research Corporation
Santa Barbara, California 93111

This paper's purpose is to suggest an interpretation of the SEM entire function that is useful in modeling the early-time portion of the scattered fields resulting from an impulsive plane wave incident on a scatterer of finite dimension. The model employed for the scattered field's time history is:

$$u(t) = \sum_{i=1}^N A_i e^{s_i t} + \sum_{k=0}^M a_k \text{Sa}(\pi t / \Delta t - k\pi)$$

where $\text{Sa}(x) = \sin(x)/x$ and Δt is the sampling time step used in the model. Methods for estimating the poles (s_i), residues (A_i) and entire coefficients (a_k) from measured data will be discussed.

The first summation in this model represents the component corresponding to the singular part of the response in the Laplace domain. The second summation represents the component corresponding to the entire function of SEM theory. The reasons for this model choice as well as the physical mechanism responsible for the entire function will be discussed.

RAY-OPTIC AND SEM MODELS IN TRANSIENT IDENTIFICATION

Donald G. Dudley, Robert Weyker, and Jay Simon
Department of Electrical Engineering
University of Arizona
Tucson, AZ 85721

Most identification algorithms developed to date in transient electromagnetics have had as their goal the identification of Singularity Expansion Method (SEM) poles in either synthetic or real data. L. B. Felsen points out that the SEM poles are but one characteristic available in electromagnetic data. Based upon his comments, we investigate both SEM and ray-optic models and find that, indeed, there are compelling reasons for seeking identification methods that look for both local and global characteristics of the electromagnetic scatterer.

We devise an algorithm to identify parameters in ray-optic solutions. We compare identification of data records, first to find SEM poles, and second to find ray-optic parameters. Finally, we comment on the outlook for identifiers based on models containing local characteristics of scatterers.

DEVELOPMENT OF A FREE-FIELD TRANSIENT SCATTERING RANGE

Michael A. Morgan
Department of Electrical Engineering
Naval Postgraduate School
Monterey, California

The Transient Electromagnetic Scattering Laboratory (TESL) has evolved through the need to provide accurately measured smoothed impulse responses of scatterers for use in conjunction with efforts related to natural resonance target identification. The history of the TESL will be traced from the original ground-plane image range to the present free-field structure.

Using a system diagram approach, the measurement procedures and signal processing which provide the smoothed impulse response are described. A novel approach to transient monostatic measurements is discussed. This technique uses a time-domain reflectometer configuration where the scatterer is considered to be a load impedance located beyond the input port of the single transmit/receive antenna. Illustrative results are discussed showing the accuracy and flexibility of the TESL.

THE TRANSIENT RESPONSE OF FINITE, OPEN, CIRCULAR CYLINDERS

P. L. Huddleston and C. Eftimiu
McDonnell Douglas Research Laboratories
St. Louis, MO 63166

The transient response of perfectly conducting, finite, open, circular cylindrical scatterers is studied. An exact analysis is based on solving the electric field integral equation by the Galerkin method using entire domain expansion functions. A perturbation approximation is developed that takes advantage of the fact that our choice of basis functions yields a strongly (three) diagonal impedance matrix. Natural frequencies and natural modes are calculated exactly and in the perturbation approximation. The singularity expansion method is used to calculate the transient surface current and the transient scattered far field in response to an incident electromagnetic pulse. These theoretically predicted time response results are compared with available experimental data.

THE CRITICAL DAMPING PHENOMENON ASSOCIATED WITH
TRANSIENT RESPONSE OF AN IMPEDANCE-LOADED
THIN-WIRE ANTENNA

Ahmad Hoorfar and David C. Chang
Electromagnetics Laboratory
Department of Electrical Engineering
University of Colorado
Campus Box 425
Boulder, CO 80309

It is well recognized that SEM representation is particularly effective in the time-domain synthesis of far-field response of an antenna structure. Equipped with an accurate analytical expression in the frequency-domain for the current induced on a thin-wire dipole antenna, we have derived simple closed-form expressions for the SEM poles (i.e., natural frequencies), natural current modes and coupling coefficients of an unloaded thin-wire antenna (IEEE-APS, 30, 6; 1145-1152, 1982). Excellent agreements with numerical works for the transient response of both transmitting as well as receiving antennas were obtained.

To facilitate the synthesis aspect of such an antenna, we have now extended the problem to include the transient far-field response of a center as well as off-center loaded antenna with a finite-size gap. The electric far-field SEM representation is given in terms of the product of the natural current mode and the so-called natural electric-field mode, for which explicit expressions are derived. We can show that for an antenna of length L and radius a , centrally loaded with a resistive element R_L , the natural frequencies of the lower order modes can vary from ones corresponding to the symmetric modes of an antenna of length L when $R_L = 0$, to ones corresponding to an antenna having half of the length, i.e. $L/2$, when $R_L \rightarrow \infty$. Modes with maximum decay rate can be accomplished for values of R_L close to the "characteristic impedance" defined as

$$Z_{ca} = \frac{\eta_0}{\pi} \left[\ln\left(\frac{L}{a}\right) - 1 \right]$$

where η_0 is the free space intrinsic impedance. Transient far-field response in that case is "critically-damped," and has a waveform similar to that of a double exponential pulse. A detailed modal structure in the complex frequency domain as a result of impedance loading, along with the effect of finite gap sizes, will be discussed. In addition, a time-dependent natural electric-field mode is defined and its importance in efficient calculation as well as physical interpretation of the "early-time" response is discussed.

ELECTROMAGNETIC PULSE PENETRATION INTO A CLOSED VOLUME THROUGH

LOSSY WALLS

by

Probir.K.Bondyopadhyay
Dept. of Electrical Engineering & Computer Sc.
New York Institute of Technology
Old Westbury, New York 11568

A high amplitude Electromagnetic Pulse created by a low altitude nuclear explosion can penetrate through an imperfect lossy wall into a closed volume in sufficient strength so as to destroy electronic circuitry contained inside. This problem, therefore, is of immense practical interest and needs to be studied.

A simple problem of this kind that permit thorough computational investigation is that of a full spherical enclosure on which a plane electromagnetic pulse is incident. Viewing free space as a spherical waveguide and the finite spherical volume a segment of it, the problem essentially reduces to a spherical transmission line excitation problem. Via Fourier Transform the Electromagnetic Pulse can be represented in terms of vector plane waves which, in turn, are transformed into vector spherical waveguide modes exciting the spherical transmission line.

Only radial variations of the dielectric and magnetic properties of the wall is assumed. Since the entire spherical cross section is involved, spherical modes with different radial indices will not be coupled. Impedance relations in spherical transmission lines ultimately yields the penetrated field amplitude.

Computer programs have been generated to compute the penetrated field strength and power densities for different kinds of lossy walls, different thicknesses and different sphere sizes. Resonance effects has been very carefully studied. Numerical results outline the wall properties needed for survival under the worst conditions.

URSI/B-2-1
SATELLITE REFLECTOR ANTENNAS (SPECIAL
SESSION)

Auditorium 2 - AH
Monday 1:30 - 4:20

CHAIRMAN: Yahya Rahmat-Samii
Jet Propulsion Laboratory
California Institute of Technology
Pasadena, CA 91103

1. (1:30) *SPECIAL SESSION ON SATELLITE REFLECTOR ANTENNAS FOR WIDE-ANGLE SCAN: INTRODUCTION AND OVERVIEW*, Y. Rahmat-Samii, California Institute of Technology, Jet Propulsion Laboratory, 4800 Oak Grove Drive, Pasadena, CA 91109
2. (1:50) *WIDE-ANGLE BEAM SCANNING PERFORMANCE OF DUAL REFLECTOR ANTENNAS*, D. F. DiFonzo, B. S. Lee, COMSAT Laboratories, Clarksburg, MD 20871
3. (2:10) *20 GHZ PROOF-OF-CONCEPT TEST MODEL RESULTS FOR A MULTIPLE SCAN BEAM DUAL REFLECTOR ANTENNA*, Tom Roberts, Howard Luh, Allen Smoll, E. W. Matthews, Wm. G. Scott, Ford Aero. & Communications Corp., WDL Division, Palo Alto, CA
4. (2:30) *OFFSET DUAL-REFLECTOR ANTENNA WITH SOLID STATE FEED MODULE FOR SATELLITE APPLICATIONS*, K. C. Lang, D. C. D. Chang, Hughes Aircraft Company, Space Antenna Systems Laboratory, El Segundo, CA 90245
5. (2:50) *WIDE ANGLE SCANNING FOR REFLECTOR ANTENNAS*, C. C. Hung, Lockheed Missiles and Space Company, Sunnyvale, CA, R. Mitra, University of Illinois, Urbana, IL
6. (3:40) *IMPROVED WIDE-ANGLE SCAN USING A MINI-MAX OPTIMIZATION TECHNIQUE*, W. A. Imbriale, V. Galindo-Israel, Y. Rahmat-Samii, California Institute of Technology, Jet Propulsion Laboratory, 4800 Oak Grove Drive, Pasadena, CA 91109, R. L. Bruce, TRW, Redondo Beach, CA
7. (4:00) *CONTOURED-BEAM SYNTHESIS BY ADJUSTING THE APERTURE PHASE IN A REFLECTOR ANTENNA*, R. Jorgensen, TICRA A/S, Copenhagen, Denmark, P. Balling, INTELSAT, Washington, D.C.

SPECIAL SESSION ON SATELLITE REFLECTOR ANTENNAS
 FOR WIDE-ANGLE SCAN: INTRODUCTION AND OVERVIEW

Y. Rahmat-Samii
 Jet Propulsion Laboratory
 California Institute of Technology
 Pasadena, CA 91109

State-of-the-art in satellite reflector antenna design requires the synthesis and analysis of reflector/feed systems having wide angle scan capabilities. The use of these reflectors is necessary to fulfill the increasing demand for multiple and contour beam satellite antennas for both commercial and military applications. Reflector concepts under current investigation can best be summarized by the diagram shown below, which demonstrates the interrelationships among different concepts with different branches in the diagram.

The session will begin with an overview of the required system parameters and the mathematical statement of the problem. The limitation of the ideal case of the one-feed-per-one-beam concept using a single parabolic reflector will be discussed. A brief summary of the newly-advanced reflector synthesis and analysis techniques will be presented, followed by the detailed presentation of each concept by the invited speakers of the session.

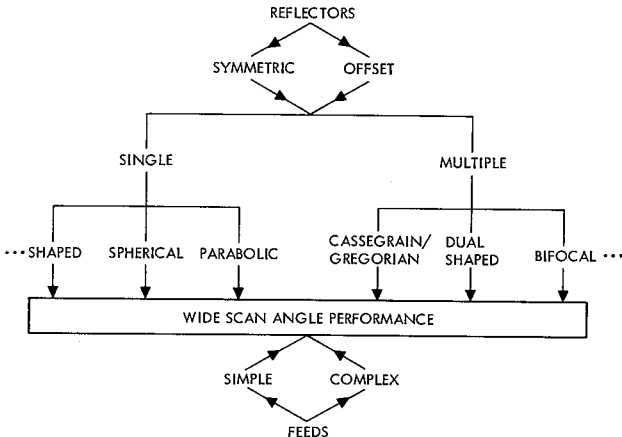

WIDE-ANGLE BEAM SCANNING PERFORMANCE
OF DUAL REFLECTOR ANTENNAS

D. F. DiFonzo and B. S. Lee

COMSAT Laboratories
Clarksburg, Maryland 20871

The capacity demands of future communications satellite systems are leading to consideration of large antenna apertures with narrow component beams for shaped isolated pattern coverages. A suitable range of component beamwidths, θ_c , is $0.2^\circ < \theta < 1^\circ$ corresponding to antenna diameters of $65 < D/\lambda < 325$ (e.g. up to 24 meters at 4 GHz). The field of view (FOV) from synchronous altitude for regional coverages such as CONUS is $\pm 4^\circ$ while INTELSAT systems might require the full earth FOV of $\pm 9^\circ$. These values imply beams scanned up to 45 beamwidths.

Conventional offset paraboloids may require large focal lengths resulting in unwieldy feed arrays and packaging geometries. Dual reflectors, on the other hand, can offer the advantages of longer effective focal length and an additional degree of design freedom allowed by the subreflector. Cassegrain and Gregorian reflectors have been shown to have superior scanning performance over their single reflector counterparts for FOV up to 6° and an offset bifocal reflector has been designed for superior scanning up to $\pm 9^\circ$. The nearfield Cassegrain or Gregorian system which consists of two confocal paraboloids fed by either a phased array or lens is a good candidate for limited scanning in satellite applications.

A comparison of the beam scanning properties of these antennas will be presented. Scan loss, sidelobe structures and cross-polarization will be compared based on similar volumetric constraints, feeds being located on the optimum feed locus, and the feed array excitations chosen to optimize specified coverage gains and isolation at extreme scan positions. The scan performance of the dual reflector systems will also be compared with that of single offset reflectors.

20 GHz PROOF-OF-CONCEPT TEST MODEL RESULTS
FOR A MULTIPLE SCAN BEAM DUAL REFLECTOR ANTENNA

Tom Roberts, Howard Luh, Allen Smoll,
E.W. Matthews and Wm. G. Scott

WDL Division
Ford Aerospace and Communications Corp.
Palo Alto, California

Under contract NAS 3-22498, from NASA Lewis Research Center, we have designed, fabricated, and pattern-tested a full scale 20 GHz antenna model. The model is intended to test the low sidelobe beam scanning capability of a new class of generalized shaped surface optics applied to the offset dual reflector and feed array configuration.

The design was derived for a future synchronous communication satellite operating in the 30/20 GHz band. A 20 GHz downlink antenna of this design will radiate 18 frequency reused 0.3° pencil beams directed at 18 cities in CONUS for telephone trunking purposes and 6 frequency reused (a separate sub-band) scanning 0.3° spot beams covering all of CONUS via TDMA for smaller CPS* terminals. The 18 plus 6 frequency re-uses are achieved by polarization purity and low (-30 dB) sidelobes of all 24 simultaneous radiating beams. A smaller antenna provides 24 corresponding uplink beams at 30 GHz.

The offset reflector and subreflector surfaces were custom shaped (to minimize ray defocussing effects over the specified scan volume) by a computer synthesis procedure subject to geometric constraints on maximum sizes, spacings and offsets of the reflectors and focal surface and to the constraint of a flat scan focal surface. Best performance was obtained by removing the constraint of figure-of-revolution surfaces.

The doubly curved shaped surface optics so derived result in calculated beam scan loss under one dB over the ± 12.3 BW** by ± 5.8 BW CONUS scan volume while maintaining -30dB sidelobes. Measured beam scan performance of the model will be compared to calculated patterns.

The high speed ferrite switched beam forming network in the model feed array will also be described.

*Customer Premises Services **Beam Width

OFFSET DUAL-REFLECTOR ANTENNA WITH
SOLID STATE FEED MODULE FOR SATELLITE APPLICATIONS

K.C. Lang and D.C.D. Chang
Space Antenna Systems Laboratory
Hughes Aircraft Company
El Segundo, California

Offset dual-reflector antennas constitute one of the best pencil beam satellite antenna candidates for wide-angle scan applications. Dual reflector antennas which utilize folded optic principles to reduce overall occupied volume usually can achieve better illumination efficiency and sidelobe control compared with single reflector or lens antennas. Because of the design freedom added by the sub-reflector, there is potential improvement of the overall antenna performance. For certain applications the reflector surfaces are shaped to minimize gain variation over a large scan angle. In some cases, the reflectors are shaped to maximize gains or minimize sidelobe/cross-polarization levels.

Gain variation, beam shape (width), sidelobe and cross-polarization level are important criteria in designing wide-angle scan antennas. Peak gain and beamwidth variation over the entire scan range determine the granularity of EIRP and G/T over the coverage area. The sidelobe and cross-polarization characteristics will dominate the C/I performance in multibeam applications. It is difficult to achieve the performance requirements by shaping the reflectors alone. However, there are other techniques in antenna design for further performance improvement. For example, the use of gridded reflectors and dual-mode feeds can improve the cross-polarization isolation and the use of cluster feed techniques can provide lower scan loss and better sidelobe suppression.

With recent advances in solid-state technology, it appears possible to control amplitudes and phases of individual feeds using light weight, small volume, low power consuming and high speed solid-state devices. The new technology advances offer the antenna designer a better chance to improve radiation efficiency and pattern control by caustic matching, especially in multiple fixed beam antenna design. In scanning beam antenna design, phased array feeds using solid-state amplifiers and phase shifters in conjunction with beam forming networks will improve the beam scanning capability. A beam forming network can be realized either by a Butler matrix or a transfer lens which can be considered as part of the optic design of the antenna. In this case, the antenna system which consists of dual reflectors, a Butler matrix (or a transfer lens) and a phased array feed can be viewed as a magnified phased array with a limited field of view.

WIDE ANGLE SCANNING FOR REFLECTOR ANTENNAS

C. C. Hung
Lockheed Missiles and
Space Company
Sunnyvale, California

R. Mittra
University of Illinois
Urbana, Illinois

Recently there has been considerable interest in extending the scan capability of reflector antennas to many beamwidths from boresight direction. The wide angle scan is accomplished by using feed arrays consisting of many feed elements (as opposed to a single feed) that are simultaneously excited with different excitation coefficients to produce proper illumination on the reflectors. With proper excitation coefficients for the feed elements, not only the pattern degradation and gain loss can be kept at a minimum, but also the sidelobe level can be controlled.

Computer programs, which use recently developed, very efficient Fourier-Bessel techniques to compute the secondary far field patterns, have been developed to study the wide angle scan capability for different reflector antennas. In addition to the parabolic reflector antennas, spherical reflector antennas are also of interest in the wide angle scan capability study because of their symmetric geometry. The scan loss, either as a function of scan angle or as a function of the number of feed elements or the feed array spacing, of both parabolic and spherical reflector antennas will be shown in this paper.

The method to compute the excitation coefficients for the feed elements to produce low sidelobe scan beams will be discussed. The wide angle scan performance of both parabolic and spherical reflector antennas with a given low sidelobe constraint will then be presented.

IMPROVED WIDE-ANGLE SCAN USING A MINI-MAX OPTIMIZATION TECHNIQUE

W. A. Imbriale, V. Galindo-Israel, Y. Rahmat-Samii
Jet Propulsion Laboratory, Pasadena, California

and R. L. Bruce
TRW, Redondo Beach, California

The secondary pattern of a reflector antenna deteriorates significantly once the beam is scanned beyond a few beamwidths. In many applications, it is necessary to scan many beamwidths from the boresight direction with minimum gain loss and pattern degradation. This can be accomplished by using a cluster feed comprising a number of horns (as opposed to a single feed horn) which are simultaneously excited with excitation coefficients chosen to produce a desired illumination function of the main reflector. This paper describes the use of a mini-max optimization technique for determining the weighting coefficients which not only enhance the gain, but can control the sidelobe levels and pattern shape as well.

An important step in the procedure is the efficient computation of the radiated far field from the reflector for different feed displacements in the focal region. The Jacobi-Bessel technique, enhanced by the use of the sampling theorem and a judicious choice of computation of the Bessel functions for each feed, is used to generate the secondary pattern and focal field distribution of the reflector antenna. With these enhancements, the Jacobi-Bessel technique is found to be computationally very efficient.

The procedure for optimizing the element coefficient values proceeds as follows. First, the focal plane distribution is examined to determine the extent and location of the feed cluster. Typically, spacings between .6 to 1.0 wavelengths and a triangular grid layout are selected. Second, assuming a circular pattern with low sidelobes is desired, a grid of secondary field points is specified which describes the area where maximum gain is desired as well as where sidelobe suppression is desired. A "cost" function is then computed by assuming an initial value for the specified secondary grid points. Over the area where maximum gain is required, the lowest gain value obtained using these coefficients is selected. Over the grid points where sidelobe suppression is required, the highest gain value is selected. The "cost" function is the difference between these two values. An optimization program is then used to vary the weight coefficients to maximize this difference.

Examples are given for a 200 wavelength diameter reflector scanned 11 and 17 beamwidths to demonstrate the improvements of this mini-max optimization technique over the plane-wave conjugate-matching technique.

CONTOURED-BEAM SYNTHESIS BY ADJUSTING
THE APERTURE PHASE IN A REFLECTOR ANTENNA

R. Jorgensen. P. Balling TICRA A/S, Copenhagen, Denmark

The concept of generating a contoured beam by shaping the surface of a reflector antenna with one feed offers a number of advantages compared to a multibeam antenna regarding feed network losses and reduced spillover.

The optimum shape of the surface is found by optimizing the phase of the aperture field. The phase is given as an expansion in orthogonal polynomials in which the coefficients of the terms are the variables to be optimized. The farfield associated to the aperture distribution is calculated at stations which represent the desired contour. Hence, we have a non-linear set of equations in which the gain levels at the stations are functions of the coefficients in the phase expansion. By means of an optimization procedure the coefficients are determined to maximize the minimum gain. The reflector surface corresponding to the selected phase distribution is finally determined by an optical ray tracing procedure.

Investigations with the method have been carried out and compared to similar multibeam designs, and the concept has been found competitive regarding minimum gain and sidelobe level. To check the optimum design a breadboard model has been manufactured and will be measured in the near future, and the results will be presented. The cost for producing the breadboard model of the shaped reflector is approximately 15000 US\$ (feed horn not included).

URSI/B-2-2
PROPAGATION

104 - AH
Monday 1:30 - 3:10

CHAIRMAN: Jerry Harris
Exxon Production Research Co.
Houston, TX 77001

1. (1:30) *RESULTS FROM 19- AND 29-GHZ BEACON SIGNAL MEASUREMENTS WITH COMSTAR SATELLITES AT CLARKSBURG, MARYLAND*, Prabha N. Kumar, COMSAT Laboratories, Propagation Studies Dept., 22300 COMSAT Drive, Clarksburg, MD 20871
2. (1:50) *APERTURE ANTENNA EFFECTS AFTER PROPAGATION THROUGH STRONG ANISOTROPIC RANDOM MEDIA*, Dennis L. Knepp, Mission Research Corp., 735 State Street, P.O. Drawer 719, Santa Barbara, CA 93102
3. (2:10) *RADIATIVE TRANSFER THEORY FOR RANDOMLY DISTRIBUTED NONSPHERICAL PARTICLES*, Akira Ishimaru, University of Washington, Dept. of Elec. Engr., Seattle, WA 98195, Cavour Yeh, University of California at Los Angeles, Electrical Engineering Dept., Los Angeles, CA 90024
4. (2:30) *MEAN WAVE PROPAGATION IN A TRUNK DOMINATED FOREST*, Roger H. Lang, George Washington University, Dept. of Elec. Engr. & Computer Science, Washington, D.C. 20052, Allan Schneider, Selim Seker, CyberCom Corporation, 4105 North Fairfax Dr., Arlington, VA 22203
5. (2:50) *RIGOROUS ANALYSIS OF WAVE PROPAGATION IN AN ALMOST PERIODIC MEDIUM*, A. Cheo, William Paterson College of New Jersey, Wayne, N.J. 07470, S. T. Peng, Polytechnic Institute of New York, Brooklyn, N.Y. 11201

Results from 19- and 29-GHz Beacon Signal Measurements
with COMSTAR Satellites at Clarksburg, Maryland

Prabha N. Kumar
Propagation Studies Department
COMSAT Laboratories
22300 COMSAT Drive
Clarksburg, MD 20871

The data on rain attenuation duration for a given fade depth are important for the determination of the switching interval in diversity operations and/or the transmitter response time for the power control operations in satellite communications. Another factor affecting the performance of earth-satellite links is the distribution of time intervals between rain fades. These data are especially useful in some communication systems, which operate in a mode of retransmitting messages, if a fade prevented their earlier transmission. This paper summarizes the measured fade duration statistics and interval between fade statistics derived from four years of beacon signal measurements from COMSTAR (D-1, D-2, and D-3) satellites. For fade depths between 3 and 25 dB, the mean fade duration ranged from 11 minutes to 3.5 minutes at 19-GHz and from 16 minutes to 7 minutes at 29 GHz. The seasonal and year-to-year variations of these fades and their dependence on elevation angles are also reported.

APERTURE ANTENNA EFFECTS AFTER PROPAGATION THROUGH
STRONG ANISOTROPIC RANDOM MEDIA

Dennis L. Knepp
MISSION RESEARCH CORPORATION
735 State Street, P.O. Drawer 719
Santa Barbara, CA 93102

An analytic solution is obtained for the two-position, two-frequency mutual coherence function for spherical wave propagation using the quadratic phase structure-function approximation valid in the strong scatter limit. Transmitter and receiver are located in free-space on opposite sides of a thick slab containing anisotropic electron density irregularities that are elongated in the direction parallel to the magnetic field. The orientation of the magnetic field line with respect to the direction of propagation is arbitrary (Briggs and Parkin, JATP, p. 339, 1963).

This general result is simplified to the case of a thin phase-screen and the response function to a transmitted delta function of power is obtained in the presence of a receiving aperture antenna. The effects of the receiving antenna on measurements of received power, decorrelation time (or distance), mean time delay, time delay jitter and coherence bandwidth are determined as functions of the aperture diameter and of the angle between the magnetic field and the direction of propagation. It is shown that in strong turbulence aperture averaging can be a significant factor in reducing the time delay jitter observed at the antenna output.

This work is directly applicable to the problem of signal propagation through a highly disturbed transionospheric channel and to the effect of the channel on large aperture antennas as could be used for space based radar observations or satellite communications.

RADIATIVE TRANSFER THEORY FOR RANDOMLY
DISTRIBUTED NONSPHERICAL PARTICLES

Akira Ishimaru, Department of Electrical Engineering
University of Washington, Seattle, WA 98195
Cavour Yeh, Electrical Engineering Department
University of California at Los Angeles
Los Angeles, CA 90024

In the past, extensive studies have been made on the scalar radiative transfer theory. They are adequate for natural light when the polarization effects can be neglected. In recent years, the vector radiative transfer theory has attracted considerable attention because of the increasing interest in the multiple scattering effects in randomly distributed nonspherical particles. Even though studies have been reported on the vector radiative transfer theory for spherical particles, the general formulations of the vector radiative transfer theory for nonspherical particles have not been fully reported in the past. This paper attempts to present a systematic and general formulation for nonspherical particles using Stokes' vectors including all polarization effects. First, the complete vector equation of transfer is given including the extinction matrix resulting from the nonspherical shapes. The coherent intensity vector is then obtained including the cross-polarization effects. The formulation for the incoherent intensity vector involves Fourier decomposition of the equation of transfer and because of the nonspherical shape, each Fourier component is coupled to each other. The incident wave is polarized and obliquely incident on a slab medium of nonspherical particles, and the transmission and backscattering are considered. Also included are the special cases of small particles and the first-order scattering solutions for nonspherical particles.

MEAN WAVE PROPAGATION IN A TRUNK DOMINATED FOREST

ROGER H. LANG, Department of Electrical Engineering and Computer Science, George Washington University, Washington, D.C. 20052
ALLAN SCHNEIDER and SELIM SEKER, CyberCom Corporation, 4105 North Fairfax Dr., Arlington, VA 22203

A trunk-like forest is modeled by an array of parallel lossy dielectric cylinders which have circular cross section of radius a . The cylinders are distributed randomly with density ρ . Propagation of both horizontal and vertical waves at oblique angles of incidence is considered.

An equation for the mean electric field is obtained by employing the Foldy-Lax discrete scattering formalism. Perturbation solutions to this equation are found for forests having a small fractional area ($\pi a^2 \rho \ll 1$). Expressions for both the horizontal and vertical propagation constants have been derived in terms of the forward scattering amplitude of a circular cylinder. Formula relating specific attenuation (db/m) and effective bulk forest permittivity to the salient trunk parameters e.g., trunk radius, wood permittivity, are given.

Results of the study show that at wavelengths large compared to the trunk radius and for propagation directions normal to the trunks vertical waves are attenuated more severely than horizontal waves. At higher frequencies where the wavelength is small compared to the trunk radius both polarization types suffer equal attenuation. Some comparison with existing experimental data will be made.

RIGOROUS ANALYSIS OF WAVE PROPAGATION IN AN
ALMOST PERIODIC MEDIUM

A. Cheo

William Paterson College of New Jersey
Wayne, N. J. 07470

and

S. T. Peng

Polytechnic Institute of New York
Brooklyn, N. Y. 11201

The theory of wave propagation in the canonical periodic medium with a sinusoidally stratified permittivity is extended to the case of an almost periodic medium with two-harmonic modulation. A new method using a combination of a three-term recurrence relation in the matrix form and the technique of noncommutative continued fractions is employed to formulate the problem rigorously. Specifically, such a new method offers the following advantages: (1) the analysis of the almost periodic medium is in a form analogous to that of the known Mathieu equation for the simpler canonical problem, (2) it applies to both commensurate and noncommensurate cases of the almost periodic medium, and (3) it gives a simple and effective algorithm for accurate numerical computations. Therefore, this method provides a general and unified approach to the solution of wave propagation in an almost periodic medium with two-harmonic modulation. Numerical results are included to illustrate the wave phenomena associated with the almost periodic medium as well as the effectiveness and accuracy of the new method.

URSI/B-2-3
SCATTERING FROM ROUGH SURFACES

104 - AH
Monday 3:40 - 5:00

CHAIRMAN: Calvin Swift
Dept. of Elec. and Computer Engineering
University of Massachusetts
Amherst, MA 01003

1. (3:40) *LOW-ANGLE BISTATIC RADAR SEA CLUTTER EXTRAPOLATED TO THE PLATEAU REGION*, George W. Ewell, Georgia Institute of Technology, Engineering Experiment Station, Atlanta, GA 30332
2. (4:00) *INVESTIGATION OF BACKSCATTER FROM AN UNEVEN, ROUGH SURFACE*, Robert J. Papa, John F. Lennon, Richard L. Taylor, Rome Air Development Center, Electromagnetic Sciences Division, Hanscom Air Force Base, MA 01731
3. (4:20) *ROUGH SURFACE SCATTERING THAT CANNOT BE ANALYZED BY PERTURBED-PHYSICAL OPTICS APPROACHES*, Ezekiel Bahar, University of Nebraska-Lincoln, Dept. of Electrical Engineering, W194 Nebraska Hall, Lincoln, NE 68588-0511, D. E. Barrick, N.O.A.A., Boulder, CO
4. (4:40) *SCATTERING CROSS SECTIONS FOR COMPOSITE SURFACES AND THE WAVENUMBER WHERE SPECTRAL SPLITTING OCCURS*, Ezekiel Bahar, University of Nebraska-Lincoln, Dept. of Electrical Engineering, W194 Nebraska Hall, Lincoln, NE 68588-0511, D. E. Barrick, N.O.A.A., Boulder, CO, M. A. Fitzwater, U. of Nebraska, Lincoln, NE

LOW-ANGLE BISTATIC RADAR SEA CLUTTER
EXTRAPOLATED TO THE PLATEAU REGION

by
George W. Ewell
Engineering Experiment Station
Georgia Institute of Technology
Atlanta, Georgia 30332

In a recent paper (Ewell and Zehner Proc. Radar-82, 188-192) data were presented for values of bistatic clutter return near grazing incidence which showed a decrease in clutter cross section per unit area with increasing bistatic angle. Since some of these measurements were made in the interference region and there was almost a 3:1 difference in transmitter and receiver antenna heights, it has been suggested that the observed decrease in clutter cross section might be accounted for by the change in propagation factor with changing geometry. In this presentation, monostatic sea clutter data will be used to correct bistatic clutter values to those in the plateau region.

The correction of data to the plateau region involves the determination of both the propagation factor, F , and the critical angle ψ_c . While these parameters are derivable from theoretical considerations, such factors as inaccuracies in sea state estimation and the possible presence of ducting make such an approach suspect. Perhaps a more satisfactory approach involves use of the observed values of monostatic return to determine ψ_c and the behavior of F . For example, applying the procedure to the data of 3 August yielded a value of $\psi_c = 0.3^\circ$, and a variation of F below ψ_c of $F = (\psi/\psi_c)^{0.75}$. Figure 1 shows the original clutter cross section ratios as a function of bistatic angle, while Figure 2 are the same data corrected to the plateau region. While data sets do not all indicate as extreme a decrease in bistatic cross section at the larger bistatic angles, a significant portion of the data evidence a distinct dependence of bistatic cross section on bistatic angle in the plateau region.

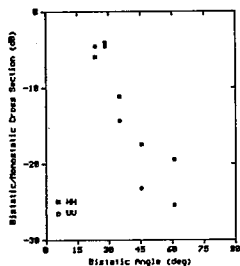

Figure 1

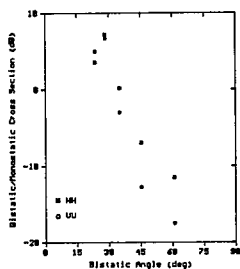

Figure 2

INVESTIGATION OF BACKSCATTER FROM AN UNEVEN, ROUGH SURFACE

Robert J. Papa
John F. Lennon
Richard L. Taylor
Electromagnetic Sciences Division
Rome Air Development Center
Hanscom AFB, MA 01731

This paper presents results obtained from an analytic description of the em waves backscattered into a monostatic system from a rough surface. First, the model is described. Then, the effects of various surface parameters on the scattered power are considered. The normalized scattering cross section of the surface, σ° is derived under the assumptions of physical optics with the surface heights described by either a bivariate Gaussian probability density or a bivariate exponential density function. The usual form for σ° has an analytical expression only for the case of large Rayleigh roughness parameter, $\Sigma = (4\pi \sigma/\lambda)\cos \theta_i$, where λ = em wavelength, σ = standard deviation in surface height and θ_i = angle of incidence. In this paper, expressions for σ° have been derived that are accurate and valid for intermediate and small values of Σ as well. Finally, comparisons are made between the analytical solutions and experimental clutter data.

The analysis is comprehensive and includes such features as spatial inhomogeneities, unevenness of the rough surface, ray blockage (global shadowing) and local shadowing. Local shadowing is accounted for by appropriate shadowing functions.

When the solutions for σ° are derived for the conditions of intermediate and small Σ , it is found that for those ranges of Rayleigh roughness parameter, the usual result of frequency independence for σ° no longer holds true. Different formulations are required for each range and surface height assumption.

The electromagnetic model has been used to determine the amount of clutter power entering the receiver as a function of the complex dielectric constant of the surface, the standard deviation in surface height, the surface correlation function and the angle of incidence. In addition, the predicted results agree with experimentally observed levels of backscatter clutter power.

ROUGH SURFACE SCATTERING THAT CANNOT BE ANALYZED BY
PERTURBED-PHYSICAL OPTICS APPROACHES
E. Bahar, U. of Nebraska, Lincoln, NE, and
D. E. Barrick, N.O.A.A., Boulder, CO

Perturbation and physical optics theories have traditionally been used to derive the scattering cross sections for composite surfaces that can be regarded as small scale surface perturbations that ride on filtered, large scale surfaces. In this case perturbation theory accounts for Bragg scattering, while physical optics theory accounts for specular point scattering. However, for a more general class of composite surfaces that cannot be decomposed in such a manner, the perturbed-physical optics approach cannot be used. In these cases, it is shown, using the full wave approach, that the specular scattering associated with a filtered surface (consisting of the larger-scale spectral components), is strongly modified, and that Bragg scattering and specular point scattering begin to blend with each other. Since the full wave solution accounts for Bragg scattering as well as specular point scattering in a self-consistent manner, it is not necessary to filter (decompose) the composite surface to evaluate the scattering cross sections in the general case. However, filtering the composite surface enhances one's physical insight as to the validity (or lack thereof) of the heuristic perturbed physical optics decomposition, and also facilitates the numerical evaluation of the scattering cross sections.

SCATTERING CROSS SECTIONS FOR COMPOSITE SURFACES AND
THE WAVENUMBER WHERE SPECTRAL SPLITTING OCCURS:
E. Bahar, U. of Nebraska, Lincoln, NE, D. E. Barrick,
N.O.A.A., Boulder, CO, and M. A. Fitzwater, U. of
Nebraska, Lincoln, NE

The scattering cross sections for composite random rough surfaces are evaluated using the full wave approach. They are compared with earlier solutions based on a combination of perturbation theory which accounts for Bragg scattering and physical optics which accounts for specular point theory. The full wave solutions which account for both Bragg scattering and specular point scattering in a self-consistent manner are expressed as a weighted sum of two cross sections. The first is associated with a filtered surface, consisting of the larger scale spectral components, and the second is associated with the surface consisting of the smaller scale spectral components. The specification of the surface wavenumber that separates the surface with the larger spectral components from the surface with the smaller spectral components is dealt with in detail. Since the full wave approach is not restricted by the limitations of perturbation theory, it is possible to examine the sensitivity of the computed values for the back-scatter cross sections to large variations in the value of the wavenumber where spectral splitting is assumed to occur.

URSI/B-3-1
NUMERICAL METHODS - I

Auditorium 2 - AH
Tuesday 8:30 - 12:00

CHAIRMAN: Robert Nevels
Department of Electrical Engineering
Texas A & M University
College Station, TX 77843

1. (8:30) *AN EFFICIENT COMPUTATIONAL MODEL FOR CALCULATING THE EM-SCATTERING FROM PENETRABLE CYLINDERS OF INFINITE LENGTH*, Jamal S. Izadian, The Ohio State University, Dept. of Elec. Eng., 1320 Kinnear Road, Columbus, OH 43212
2. (8:50) *CONVERGENCE OF THE "SPECTRAL-ITERATIVE TECHNIQUE" FOR THE CASE OF DIELECTRIC SCATTERERS*, M. F. Sultan, Raj Mittra, University of Illinois, Electrical Engineering Dept., 1406 W. Green, Urbana, IL 61801
3. (9:10) *APPLICATION OF THE SPECTRAL ITERATIVE TECHNIQUE FOR ANALYZING BIOLOGICAL SCATTERERS AT 915 MHz*, M. F. Sultan, Raj Mittra, University of Illinois, Electrical Engineering Dept., 1406 W. Green, Urbana, IL 61801
4. (9:30) *TWO-DIMENSIONAL PLANE WAVE SCATTERING FROM RADIALY-DIRECTED STRIPS IN THE PRESENCE OF A CYLINDER*, Donald F. Hanson, Chalmers H. Butler, University of Mississippi, Dept. of Electrical Engineering, University, MS 38677
5. (9:50) *SOLUTION OF THE PROBLEM OF THE JUNCTION BETWEEN OPEN AND CLOSED BODIES IN ELECTRIC FIELD INTEGRAL EQUATION ALGORITHMS*, Kenneth J. Harker, SRI International, 333 Ravenswood Avenue, Menlo Park, CA 94025
6. (10:40) *APPLYING THE FINITE DIFFERENCE TECHNIQUE TO A WIRE ANTENNA IN SEA WATER*, Dennis E. Fessenden, Naval Underwater Systems Center, New London Laboratory, New London, CT 06320
7. (11:00) *PERSONAL COMPUTER APPLICATIONS IN ELECTROMAGNETICS*, E. K. Miller, G. J. Burke, Lawrence Livermore National Laboratory, P.O. Box 5504, L-156, Livermore, CA 94550
8. (11:20) *A SURVEY OF NUMERICAL METHODS FOR SOLUTION OF LARGE SYSTEMS OF LINEAR EQUATIONS*, Tapan K. Sarkar, Rochester Institute of Technology, Dept. of Elec. Engr., P.O. Box 9887, Rochester, NY 14623
9. (11:40) *ON THE UTILIZATION OF ITERATIVE METHODS TO SOLVE OPERATOR EQUATIONS*, Tapan K. Sarkar, Rochester Institute of Technology, Dept. of Elec. Engr., P.O. Box 9887, Rochester, NY 14623

AN EFFICIENT COMPUTATIONAL MODEL FOR CALCULATING THE EM-SCATTERING
FROM PENETRABLE CYLINDERS OF INFINITE LENGTH

Jamal S. Izadian

The Ohio State University ElectroScience Laboratory
Department of Electrical Engineering
Columbus, Ohio 43212

ABSTRACT

An integral-equation formulation is used to obtain numerical results for the scattered fields of a penetrable cylinder immersed in either a lossy half space or a lossy homogeneous medium. The cylinder is illuminated by either a parallel electric or a parallel magnetic line source. A set of plane waves interior to the inhomogeneity (scatterer) is used as basis functions. This results in more than an order of magnitude decrease in the computation time required to obtain numerical results for larger sized targets.

Further, the integral equation solution is extended to include the planar interface between the air and the earth. The validity of the approximate forms proposed earlier to represent the interface is re-examined.

CONVERGENCE OF THE "SPECTRAL-ITERATIVE TECHNIQUE"
FOR THE CASE OF DIELECTRIC SCATTERERS

M. F. Sultan and R. Mittra
Electrical Engineering Department
University of Illinois
Urbana, Illinois

The recently developed "Spectral-Iterative Technique" (SIT) has been successfully applied to a wide range of problems involving perfectly conducting scatterers, dielectric scatterers, and a combination of both. In the following, the necessary and sufficient conditions for convergence of the iterative procedure are discussed for the special case of dielectric scatterers. It is found that the spatial-current vector at the n -th iteration is given by

$$\underline{J}_n = \underline{J}_{\text{ex}} + \underline{M}^n (\underline{J}_0 - \underline{J}_{\text{ex}}) \quad (1)$$

where the vectors $\underline{J}_{\text{ex}}$ and \underline{J}_0 are the exact current and the initial guess for the current, respectively, and where the \underline{M} matrix is a function of the dielectric properties of the scatterer and the spacing between the sampling points.

From equation (1), it is seen that

$$\underline{J}_n \rightarrow \underline{J}_{\text{ex}} \text{ with } n \rightarrow \infty \quad (2)$$

provided

$$\underline{M}^n \rightarrow \underline{0} \text{ with } n \rightarrow \infty \quad (3)$$

where $\underline{0}$ is the null matrix. Condition (3) is satisfied when

$$|\underline{M}| \equiv \max_k |\lambda_k| < 1 \quad (4)$$

where $|\underline{M}|$ denotes the spectral radius of \underline{M} , and λ_k are the eigenvalues of the matrix. It is found that $|\underline{M}|$ depends on the dielectric properties of the scatterer and on the spacing between the sampling points. For a particular scatterer with fixed dielectric properties, the spacing between the sampling points may be chosen such that condition (4) is satisfied. The details of what may be an optimal spacing between samples are being investigated. Note that convergence of the iterative procedure does not depend on the initial guess for the current.

APPLICATION OF THE SPECTRAL ITERATIVE TECHNIQUE FOR
ANALYZING BIOLOGICAL SCATTERERS AT 915 MHz

M. F. Sultan and R. Mittra
Electrical Engineering Department
University of Illinois
Urbana, Illinois

Interest in hyperthermia has prompted the development of analytical and numerical techniques for evaluating the electromagnetic power deposition in the interior of biological media. At the frequencies of interest, i.e., 915 and 2450 MHz, this type of problem cannot be adequately treated with conventional methods, e.g., the low-frequency techniques based on the method of moments, or the high-frequency asymptotic techniques which employ the geometrical theory of diffraction (GTD). However, the recently developed "Spectral-Iterative Technique" (SIT) appears to be well-suited for handling the inhomogeneous, dielectric-body scattering problem in the intermediate or resonant frequency range. In its original form, the SIT technique was designed to solve problems involving only the perfectly conducting scatterer. However, the method can be easily extended to include dielectric bodies. With the modified version of the original SIT, we were able to solve for the power deposited at 915 MHz in a wide range of problems including two or more infinite planar layers of fat and muscle media, and cylindrical structures constituted of fat alone, muscle alone, or a combination of both. Power deposition has been successfully obtained in bodies with dimensions as large as 12x the wavelength in muscle or fat. Conditions for convergence of the iterative scheme have been investigated and are discussed in more detail in an accompanying paper.

TWO-DIMENSIONAL PLANE WAVE SCATTERING FROM
RADIALLY-DIRECTED STRIPS IN THE PRESENCE OF
A CYLINDER

Donald F. Hanson and Chalmers M. Butler, Department of Electrical
Engineering, University of Mississippi, University, MS 38677

In view of the interest in scattering by aircraft and missiles the authors investigate scattering of a specified incident field by a two-dimensional conducting cylinder with attached radially-directed conducting strips. The incident field may be either a plane wave or that due to a line source but in either case is taken to be transverse magnetic to the strip and cylinder axes. An integral equation is derived for the current induced on the strip (or strips) in the presence of the cylinder and this equation is solved numerically. The integral equation kernel contains an infinite series of Bessel functions which is slowly convergent, so an acceleration technique is introduced to limit the number of terms necessary for evaluation. Data are presented several cases of interest.

SOLUTION OF THE PROBLEM OF THE JUNCTION BETWEEN
OPEN AND CLOSED BODIES IN ELECTRIC FIELD INTEGRAL EQUATION ALGORITHMS

K. J. Harker
SRI International
333 Ravenswood Avenue
Menlo Park, CA 94025

Electric field integral equation algorithms for scattering problems, such as the ESSAS or "Electromagnetic Scattering by Surfaces of Arbitrary Shape" program (S.M. Rao, D. R. Wilton, and A. W. Glisson, IEEE Trans. on Antennas and Propagation - AP-30, 409-418, 1982) are known to be applicable to both open and closed surfaces. The case of the union of an open and closed body presents special problems along the line of attachment of the two bodies. An example would be along the junction of a plate attached to a cylindrically shaped body. This problem has been solved by taking the limit as a portion of a closed body collapses to the open body configuration. The solution resulting from this process will be presented and its implementation on ESSAS discussed.

APPLYING THE FINITE DIFFERENCE TECHNIQUE
TO A WIRE ANTENNA IN SEA WATER

DENNIS E. FESSENDEN
Naval Underwater Systems Center
New London Laboratory
New London, Connecticut 06320

Antennas in sea water or near the air sea interface have been of interest to the Navy for years. A technique that appears to have promise for handling complex antenna geometries is the finite difference technique. A frequency-domain finite difference code was developed to calculate the electric field and series impedance of an infinite wire antenna in sea water. Excellent agreements are obtained with the classical electric field solutions for an extremely wide range of frequencies. For example, the error between the finite difference calculation and the classical Hankel function field decay with distance from the wire is less than 2.5 per cent out to 8 skin depths at a frequency of 100 MHz. The distance spacing between calculations was one-fiftyith of a wavelength in the sea water medium and the sinusoidal exciting field source was run for twenty cycles. Very good agreement was obtained with the series impedance also. The inductive reactance comparison was 0.5 per cent and the resistance comparison was about 10 per cent at 100 MHz. This problem serves as a stepping stone to more complicated problems where the antenna size is very definitely comparable to many cell sizes.

PERSONAL COMPUTER APPLICATIONS IN ELECTROMAGNETICS

E. K. Miller and G. J. Burke
Lawrence Livermore National Laboratory
P. O. Box 5504, L-153
Livermore, California 94550

L-153

It is barely ten years since introduction of the HP 35 scientific hand calculator, and six years since the first non-hobbyist, personal computers made their appearance (e.g., the Apple II, Commodore PET, Radio Shack TRS 80). Now, second and third generation PCs are becoming available including the IBM PC, and the Apple LISA. These personal computers are advancing well beyond the role of arcade-game players, providing the computing power necessary for solving significant scientific and engineering problems. The purpose of this paper is to review briefly the capabilities of present PCs, and to illustrate their use for solving three kinds of electromagnetic problems.

First, a version of Mini-NEC, developed at Naval Ocean Systems Center by A. J. Julian, J. C. Logan and J. W. Rockway ("Mini-NEC: A Mini-numerical Electromagnetic Code," NOSC Technical Document 516, 6 September 1982) will be outlined. This code, written in BASIC for an Apple II + computer, can handle in-core antenna and scattering problems involving wire objects having up to 55 segments. Second, a microcomputer version of TWTG, implemented by J. A. Landt of Los Alamos National Laboratory on a Commodore VIC 20 and adapted to an Apple II + by the author, will be discussed. This is a time-domain code for modeling impulsively excited wire objects as antennas or scatterers (E. K. Miller, "Time-Domain Modeling of Wires in Applications of the Method of Moments to Electromagnetic Fields," B. J. Strait Editor, SCEE Press, 1980). Finally, the use of a PC for Prony-type signal processing including SEM pole calculation and eigen-value analysis, will be considered. These three representative applications will demonstrate that presently available PCs already have useful capabilities, with the promise that next-generation PCs will permit even more demanding problems to be handled.

A SURVEY OF NUMERICAL METHODS FOR SOLUTION
OF LARGE SYSTEMS OF LINEAR EQUATIONS

Tapan K. Sarkar
Department of Electrical Engineering
Rochester Institute of Technology
Rochester, New York 14623

Abstract: The problem of radiation and scattering from electromagnetic structures may be formulated in terms of the E - field, H - field, or the combined field integral equations. The integral equations are generally then reduced to matrix equations for ease of computation. Hence the maximum size of an electromagnetic field problem that can be solved by such a technique depends on how efficiently solutions of a set of simultaneous equations are obtained.

The objective of this paper is to survey many of the popular methods of large full matrix equations with the hope of finding an efficient method.

The survey will consist of the direct methods for solving matrix equations, i.e., LU decomposition and Gaussian elimination. We will then discuss about linear iterative methods which consist of Gauss's Hand Relaxation method, Jacobi's cyclical iteration method, Seidel's method, back and forth Seidel method and Monte Carlo method.

However the convergence of linear iterative methods is much slower than the rate of convergence of nonlinear iterative methods. The nonlinear iterative methods consist of the method of steepest descent and conjugate gradient.

It will be shown that the method of conjugate gradient is a finite step iterative method and is related to the direct method of Gaussian elimination. The advantages of an iterative method over a direct method is that an iterative method round-off and truncation is generally limited to the last state of iteration.

A brief description of some of the techniques to be discussed is available in Sarkar et.al., (Methods for Solution of Linear Equations, I.E.E.E. Transactions, AP, Nov. 1980, pp. 847-856).

ON THE UTILIZATION OF ITERATIVE
METHODS TO SOLVE OPERATOR EQUATIONS

Tapan K. Sarkar
Department of Electrical Engineering
Rochester Institute of Technology
Rochester, New York 14623

Abstract: The approximate methods of solving integral and integro-differential equations $AX=Y$ of electromagnetics are varied in respect to the ideas lying at their foundation. A number of methods (variational method, Rayleigh-Ritz method, Galerkin's method and so on) has been elaborated. At the same time the analysis of these methods, particularly in electromagnetic theory, has not advanced far. Most of these methods have remained without any theoretical analysis and have only been verified by their effectiveness in individual examples. The most disturbing point is often these methods are applied routinely without investigating the positive definiteness of the operator A.

The bone of contention is the following: Each numerical method minimizes certain error criterion. In the matrix methods, one minimizes a weighted version of the error to zero, i.e.,

$$\langle E_n, \omega_j \rangle = \langle AX_n - Y, \omega_j \rangle = 0 \text{ for } j = 1, 2, \dots, n.$$

where X_n is the approximation of X exact. Observe this error is meaningful only if $E_n(z)$ is positive for all z . Minimization of $\langle E_n, \omega_j \rangle$ is meaningful only when A is positive definite and not positive real (which comes from energy considerations). If $E_n(z)$ is not positive then minimization of this error is mathematically meaningless - yet this is regularly done in numerical electromagnetics.

This is why we propose to utilize iterative methods to solve electromagnetic field problems. In iterative methods, we minimize the mean squared error $\langle E_n, E_n \rangle = \langle AX_n - Y, AX_n - Y \rangle$ at each iteration. Therefore as iteration progresses we get a more accurate answer. This has been demonstrated by S.G. Mikhlin [The problem of the minimum of a quadratic functional, Holden Day Inc., 1965, p.26]. Mikhlin states, "The essential advantage of the method of least squares is that the approximate solution which is constructed by means of it satisfies the equation $AX=Y$ to any prespecified given order of accuracy. This circumstance generally speaking, improves the nature of convergence $X \rightarrow X_{\text{exact}}$." Therefore by iterative methods it is possible to solve any operator equation to any degree of accuracy. In matrix methods, however, since no meaningful error is minimized when the operator A is not positive definite, one is not guaranteed to have a better answer as one increases the order of approximation.

These concepts will be explained by numerical examples.

URSI/B-3-2
HIGH FREQUENCY TECHNIQUES

101 - AH
Tuesday 8:30 - 12:00

CHAIRMAN: R. J. Pogorzelski
Space & Technology Group
TRW Electronics and Defense
Redondo Beach, CA 92078

1. (8:30) *A UNIFORM GTD ANALYSIS OF THE EM DIFFRACTION BY A THIN-DIELECTRIC HALF PLANE*, P. H. Pathak, R. Rojas-Teran, The Ohio State University, Dept. of Elec. Engr., 1320 Kinnear Road, Columbus, OH 43212
2. (8:50) *DIFFRACTION BY A PERFECTLY CONDUCTING HALF-PLANE RESIDING ON A DIELECTRIC SLAB*, Robert D. Cobin, L. W. Pearson, University of Mississippi, Dept. of Electrical Engineering, University, MS 38677
3. (9:10) *PHYSICAL THEORY OF DIFFRACTION COMBINED WITH A FOCK ANSATZ*, D.-S. Y. Wang, L. N. Medgyest-Mitschang, McDonnell Douglas Research Laboratories, St. Louis, MO 63166
4. (9:30) *RADAR CROSS SECTION ANALYSIS BY THE PHYSICAL THEORY OF DIFFRACTION*, Hung Ban Tran, T. J. Kim, Northrop Corporation, Aircraft Division, Hawthorne, CA 90250
5. (9:50) *THE EDGE WAVE AS A UNIFICATION TOOL FOR HIGH FREQUENCY E.M. DIFFRACTION BY EDGES OF VARIOUS CROSS SECTIONS*, P. Langlois, R. Delleuil, Universite de Provence, Dept. de Radioelectricite, Rue H. Poincare, 13 397 Marseille, Cedex 13, France
6. (10:40) *NEAR FIELD COUPLING OF HORN ANTENNAS NEAR LAYERED DIELECTRICS*, C. S. Kim, M. D. Tew, University of Mississippi, Department of Electrical Engineering, University, MS 38677
7. (11:00) *NUMERICAL EVALUATION OF VARIOUS RADIATION INTEGRALS USING SIMPSON'S RULE WITH LINEARLY VARYING INTERVALS*, Alexander C. Brown, Jr., Goodyear Aerospace Corp., Arizona Division, P. O. Box 85, Litchfield Park, AZ 85340-0085
8. (11:20) *SUBREFLECTOR SCATTERING PATTERNS OF A SHAPED DUAL-REFLECTOR ANTENNA - GTD SOLUTION*, Yuan-heng Qiu, Shanghai Jiao-Tong University, Shanghai, People's Republic of China
9. (11:40) *THE WIDE ANGLE SIDELOBES OF SHAPED DUAL- REFLECTOR ANTENNA - GTD SOLUTION*, Yuan-heng Qiu, Min-Yi Shen, Shanghai Jiao-Tong University, Shanghai, People's Republic of China

A UNIFORM GTD ANALYSIS OF THE
EM DIFFRACTION BY A THIN-DIELECTRIC HALF PLANE

P.H. Pathak and R. Rojas-Teran
The Ohio State University ElectroScience Laboratory
Department of Electrical Engineering
Columbus, Ohio 43212

A uniform geometrical theory of diffraction (UTD) analysis is presented for the two-dimensional problem of electromagnetic (EM) diffraction by a thin dielectric half plane which is excited by either a plane, cylindrical, or a surface wave field. A solution to this problem is synthesized from the solutions to the problems of EM plane (or surface) wave diffraction by configurations involving perfectly-conducting electric and magnetic wall bisections of the dielectric half plane, respectively. For a sufficiently thin dielectric half plane, the electric and magnetic wall bisection problems can be appropriately approximated and then solved rigorously via the Wiener-Hopf technique. The final solution is expressed in a simple form similar to the UTD solution for the perfectly-conducting half plane diffraction problem; furthermore, the Wiener-Hopf factors contained in this solution are also relatively simple. This UTD solution is continuous everywhere exterior to the half plane including the reflection and transmission shadow boundaries. Also, this solution is valid for incident (plane and cylindrical) ray optical fields which exhibit a rapid spatial variation at the edge; the latter give rise to slope diffraction effects. Examples illustrating the accuracy of the present solution will be shown. Both TE and TM cases are considered in this work. A coupling between the scattered TE and TM waves can occur in the three-dimensional case of waves obliquely incident on the dielectric edge; a solution to the latter problem is currently being completed, and it will be reported in the future.

DIFFRACTION BY A PERFECTLY CONDUCTING HALF-PLANE
 RESIDING ON A DIELECTRIC SLAB: R. Dawson Coblin
 and L. Wilson Pearson, Department of Electrical
 Engineering, University of Mississippi,
 University, MS 38677

The problem of electromagnetic scattering by a perfectly conducting half-plane residing on the surface of a dielectric slab as shown in the figure below may be formulated as a Wiener-Hopf integral equation. One is forced to resort to numerical evaluation of integral factorization formulas to arrive at a solution for the Wiener-Hopf problem. An analysis of the Green's function for the slab structure was carried out by Whitmer (Proc. I.R.E., v. 36, 1948, pp. 1105-1109) for the case of lossless media and proves useful in the present analysis.

In this presentation we report the results of a study in which a numerically augmented solution to the Wiener-Hopf equation was carried out for the case of lossless media and TM excitation. The formal factorization integral is presented and altered to a form which lends itself to efficient numerical evaluation. The asymptotic evaluation of the diffracted fields exterior to the slab is discussed and the respective field constituents are given physical interpretation.

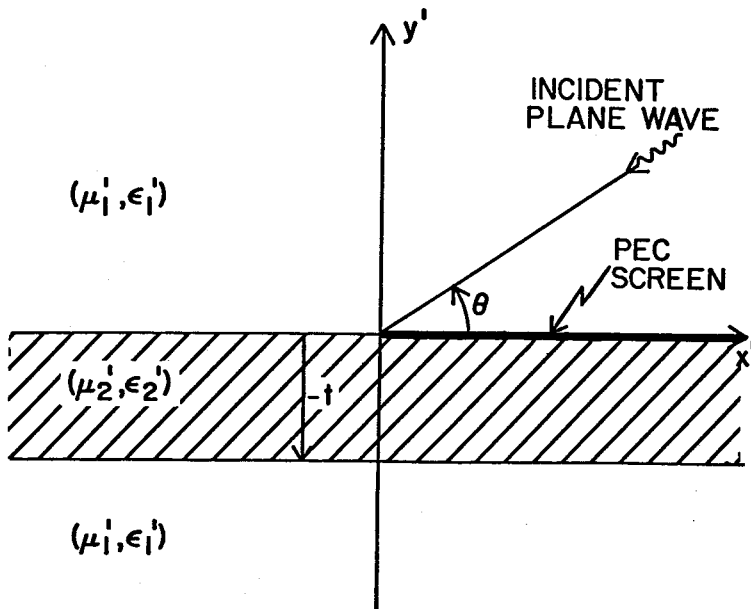

PHYSICAL THEORY OF DIFFRACTION
COMBINED WITH A FOCK ANSATZ

D.-S. Y. Wang and L. N. Medgyesi-Mitschang
McDonnell Douglas Research Laboratories
St. Louis, MO 63166

A formulation, conceptually parallel to the physical theory of diffraction (PTD) developed by Ufimtsev, is presented which extends the applicability of the original PTD to arbitrarily shaped, electrically large, perfectly conducting bodies with or without edges.

The present formulation combines a Fock theory-based Ansatz for the currents on the smooth convex part of the body and the fringe-wave theory used by Ufimtsev for currents near surface discontinuities, such as edges. The asymptotic representations, provided by the Fock Ansatz, for the currents at the shadow boundary and in the shadow region enables the present formulation to include secondary surface wave effects, such as creeping waves. The scattered far fields, arising from the currents obtained by using the Fock Ansatz and the fringe-wave theory, are expressed in terms of an explicit surface integral yielding finite fields everywhere. In general for non-axisymmetric bodies, this integral is evaluated numerically. Application of this formulation to arbitrary closed convex cylinders for oblique plane wave illumination is demonstrated. The efficacy of this formulation for finite and semi-infinite open cylinders is also examined. Comparisons are made with experimental data as well as solutions obtained using the Wiener-Hopf theory for semi-infinite bodies, and the method of moments for finite ones.

RADAR CROSS SECTION ANALYSIS BY THE
PHYSICAL THEORY OF DIFFRACTION

H. B. Tran and T. J. Kim
Northrop Corporation
Aircraft Division
Hawthorne, CA 90250

A method is presented which utilizes the equivalent current concept developed at Ohio State University along with Ufimtsev's fringe wave current to calculate the monostatic and bistatic radar cross sections (RCS) of a circular or elliptical cylinder, a polygonal cylinder or a combination of all of these. The analysis is based on the assumption that the scattered field from a target can be approximated by the sum of the scattered field from all its individual parts.

The equivalent current technique is first applied to the geometrical theory of diffraction (GTD) and the physical theory of diffraction (PTD) both in two dimensions. The analysis for an arbitrarily oriented wedge of finite length is then derived. The physical optics formulation, which is useful for the PTD method, is also presented.

Results of the monostatic and bistatic RCS of various configurations will be shown and compared with the GTD results or with the measurements.

THE EDGE WAVE AS A UNIFICATION TOOL FOR HIGH FREQUENCY E.M. DIFFRACTION BY EDGES OF VARIOUS CROSS SECTIONS.

P. LANGLOIS et R. DELEUIL

Departement de Radioélectrité, Université de Provence,
Rue H. Poincaré, 13 397 MARSEILLE, CEDEX 13.

A short historical introduction is given for a better understanding of the edge wave concept in diffraction as introduced by Thomas Young in 1802. We then investigate the E.M. edge wave emitted by straight edges of various cross sections (half plane, wedge, parabolic cylinder and circular cylinder). We consider an incident plane wave whose propagation vector is perpendicular to the edges (see Figure 1). We show that in every case we get exactly the same form for the expression of the edge wave (U_{edge}) that is

$$U_{\text{edge}}(P) = \frac{e^{i(k\rho - \omega t + \pi/4)}}{\sqrt{2\pi k\rho}} K_p(\phi : g, \vec{n})$$

where the cylindrical coordinates ρ, ϕ are defined in Figure 1 and K represents the obliquity factor of this cylindrical wave.

The difference from one specific edge cross section to the other is found in this obliquity factor via the geometric parameter g . This obliquity factor also depends upon the polarization state (represented by the subscript p) and the complex index \vec{n} of the material.

We also present numerical and experimental results for K_p .

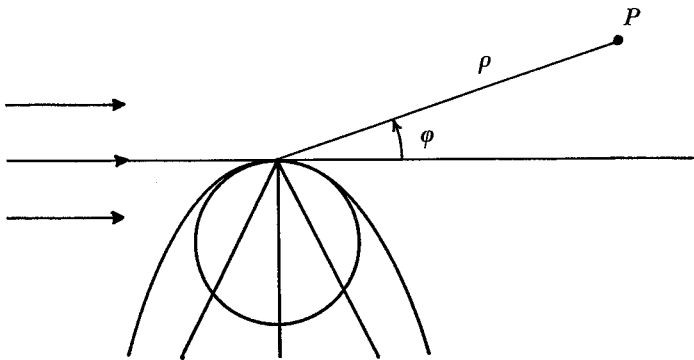

Figure 1. Diffraction of a plane E.M. wave by straight edges of various cross sections (half plane, wedge, circular cylinder and parabolic cylinder).

NEAR FIELD COUPLING OF HORN ANTENNAS NEAR LAYERED DIELECTRICS

C.S. Kim and M.D. Tew, Department of Electrical Engineering,
University of Mississippi, University, Mississippi 38677

Abstract: Computation of the near-field coupling between horn antennas near a dielectric interface is a complex problem often involving computation of Sommerfeld Integrals. This work uses ray-type techniques (GTD) to compute the coupling between identical horn antennas located near 1) a plane of perfect electric conductor, 2) an interface with a dielectric half space, and 3) planar layered dielectrics. Experimental measurements were carried out to verify the analytically derived results. Agreement between the analytical and experimental results is good.

This work has application to the Coal Interface Radar and other electromagnetic sensing applications.

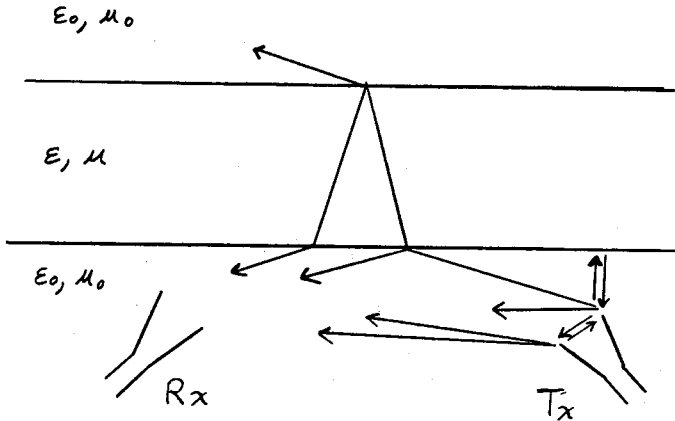

Figure: A few of the many possible coupling paths

NUMERICAL EVALUATION OF VARIOUS
RADIATION INTEGRALS USING SIMPSON'S
RULE WITH LINEARLY VARYING INTERVALS

Alexander C. Brown, Jr.
Goodyear Aerospace Corporation
Arizona Division
P.O. Box 85
Litchfield Park, Arizona 85340-0085

In the field analysis of various practical reflector antennas, one encounters various radiation integrals which arise out of applying Maggi-Rubinowicz or Kirchhoff-Huygens-Silver theories. For many situations of practical interest, these integrals must be evaluated numerically. Usually, these integrals are evaluated by applying integrating algorithms, such as trapezoidal or Simpson's rule, in a composite fashion. These methods have equal length intervals. Alternately, Gaussian quadratures, which uses unequal length intervals, are applied sometimes, because for some situations they are more accurate. None of the integration routines uses a priori knowledge about the integral to aid in its evaluation. This paper presents an integrating algorithm which accounts for the behavior of the integrals, thus significantly reducing computer run times.

The aforementioned radiation integrals exhibit either singular behavior, continuously changing rates of oscillation, or a combination of both with respect to the variables of integration. For these cases, an integration routine with linearly varying intervals prevents oversampling parts of the integrand, causing needlessly high computer run times. This new routine also prevents the using of so many integration points that one encounters problems with roundoff error. A new algorithm using composite Simpson's rule integration with linearly varying intervals has been tested against the logarithm defining integral and the Fresnel integral. For the same level of accuracy, the computer run times are 20 percent and 30 percent, respectively, of those using standard composite Simpson's rule with equal intervals. This new routine will be demonstrated on some field analysis problems involving reflector antennas.

Subreflector Scattering Patterns of a Shaped
Dual-Reflector Antenna---GTD Solution

Yuan-heng Qiu
Shanghai Jiao-Tong University
People's Republic of China

Abstract

The subreflector scattering patterns of a shaped dual-reflector antenna are calculated by GTD and UTD. The calculations of scattered fields are combined with the shaping of antenna reflectors.

The Wide Angle Sidelobes of Shaped Dual-Reflector
Antennas---GTD Solution

Yuan-heng Qiu and Min-Yi Shen
Shanghai Jiao-Tong University
People's Republic of China

Abstract

The sidelobes of a dual-reflector antenna are calculated by GTD and UTD. Both the computed and measured results of radiation are given. The agreements between them are good.

URSI/B-3-3
INVERSE SCATTERING - I

102 - SW
Tuesday 8:30 - 12:00

CHAIRMAN: Dwight Jaggard
Moore School of Electrical Engineering
University of Pennsylvania
Philadelphia, PA 19104

1. (8:30) *DIRECT AND INVERSE SCATTERING PROBLEM FOR BURIED BIDIMENSIONAL INHOMOGENEITIES*, B. Duchene, Ch. Pichot, W. Tabbara, Laboratoire des Signaux et Systemes, Groupe d'Electromagnetisme, CNRS - ESE, Plateau du Moulon, 91190 GIF-sur-YVETTE, France
2. (8:50) *A POFFIS-IDENTITY FOR REAL LIFE DATA*, D. Bruck, M. Fischer, Universitat des Saarlandes, Fachgebiet Theo. Elektrotechnik, FB 12, D-6600 Saarbrücken, FRG, Germany, K. J. Langenberg, Universität-Gesamthochschule Kassel, Fachgebiet Theo. Elektrotechnik, FB 16, D-3500 Kassel, FRG, Germany
3. (9:10) *BASIC THEORY OF RADAR POLARIMETRY*, Wolfgang-M. Boerner, University of Illinois at Chicago, Dept. of Elec. Engr. & Computer Sciences, P.O. Box 4348, Chicago, IL 60680
4. (9:30) *POLARIMETRIC DEPENDENCE OF RESIDUES IN THE RADAR TARGET RESONANCE DESCRIPTION*, Vithal K. S. Mirmira, Wolfgang-M. Boerner, University of Illinois at Chicago, Dept. of Elec. Engr. & Computer Science, P. O. Box 4348, Chicago, IL 60680
5. (9:50) *THE STATE SPACE APPROACH TO THE DIRECT AND INVERSE PROBLEMS IN LOSSY LAYERED MEDIA*, C. Q. Lee, R. Shegati, M. Burns, University of Illinois at Chicago, Dept. of Elec. Engr. & Computer Science, P.O. Box 4348, Chicago, IL 60680
6. (10:40) *VECTOR DIFFRACTION TOMOGRAPHY*, Chau-Wing Yang, Wolfgang-M. Boerner, University of Illinois at Chicago, Dept. of Elec. Engr. & Computer Science, P. O. Box 4348, Chicago, IL 60680
7. (11:00) *FURTHER RESULTS ON WAVE EQUATIONS FOR RADIATING AND NONRADIATING SOURCES, AND ON UNIQUENESS FOR INVERSE SOURCE AND INVERSE SCATTERING PROBLEMS*, W. Ross Stone, IRT Corporation, 1446 Vista Claridad, La Jolla, CA 92037
8. (11:20) *A VECTOR INVERSE ALGORITHM FOR ELECTROMAGNETIC SCATTERING*, Brett Borden, Naval Weapons Center, Michelson Lab., Physics Division, Code 3814, China Lake, CA 93555
9. (11:40) *INVERSE ELECTROMAGNETIC SCATTERING FOR RADIALLY INHOMOGENEOUS DIELECTRIC SPHERES*, Cornel Erimiu, McDonnell Douglas Research Laboratories, P. O. Box 518, St. Louis, MO 63166

DIRECT AND INVERSE SCATTERING PROBLEM FOR
BURIED BIDIMENSIONAL INHOMOGENEITIES

B. DUCHENE, Ch. PICHOT, W. TABBARA
Groupe d'Electromagnétisme
Laboratoire des signaux et Systèmes
CNRS - ESE, Plateau du Moulon
91190 GIF-sur-YVETTE (FRANCE)

This paper is devoted to the diffraction (direct and inverse) of a plane wave by buried bidimensional inhomogeneities. This is a convenient model for many physical problems and particularly those related to biomedical applications which will be addressed here.

By means of the Green's theorem, an exact solution of the direct problem based on an integral representation of the fields allows to obtain the scattered field anywhere inside or outside the object. The sensitivity of the scattered field to the object shape, orientation, depth and constitutional parameters (permittivity, conductivity in electromagnetic, density, sound velocity in acoustics) is investigated for both lossy or lossless medium.

An approximated method based on Geometrical Optics has been also developed. This one has the advantage to show explicitly the field dependence on the constitutional parameters. Comparison between the exact integral solution and the approximate one shows good agreement.

From the knowledge of the backscattered field on a finite domain we shall show how to determine some of the unknown acoustical or electromagnetic characteristics of a cylindrical shell (geometrical parameters, depth from the interfaces, sound velocity, pressure) using the approximate solution. Various results are provided for shells of different thicknesses, buried deeply or not and with various constitutional parameters.

In particular we shall emphasize the application to the characterization of blood vessels.

A POFFIS-IDENTITY FOR REAL LIFE DATA

D. Brück

M. Fischer

Fachgebiet Theoretische Elektrotechnik, FB 12

Universität des Saarlandes

D-6600 Saarbrücken (FRG)

K.J. Langenberg

Fachgebiet Theoretische Elektrotechnik, FB 16

Universität-Gesamthochschule Kassel

D-3500 Kassel (FRG)

The POFFIS-identity (Physical Optics Far-Field Inverse Scattering) as derived by Bojarski and Bleistein for the characteristic function of a scattering body is strictly valid only for the physical optics scattered field; in real life, this field is never available. It is readily obvious, that frequency band-limited data, when inserted into the POFFIS-algorithm always yield a reconstruction, which is closely related to the singular function of the scatterer, i.e. an edge enhancement is observed. The paper presents a rigorous derivation of this new singular function, which, interpreted in the time domain, is composed of a real and imaginary part representing a pair of Hilbert-transforms. Thus, the boundary of the scatterer is exactly given by the maximum value of the magnitude of this singular function. A similar, heuristically derived procedure is known as envelope detection in Synthetic Aperture Focusing Techniques (SAFT); the close relationship to another inverse scattering scheme, the inverse Born technique (IVB) is also pointed out. This sheds some light on the question how the actual boundary conditions on the scatterers surface reflect themselves in the reconstruction results. Again the singular function concept proves superior and quasi-independent of the boundary conditions. All these results are illustrated by computer-simulated results for the case of two-dimensional (scalar) scatterers with arbitrary elliptical cross-sections, also emphasizing the strong need of specular reflection to be present in a limited aperture if the scattering surface should be reconstructed with confidence. This is especially true for the limiting case of strip-like scatterers. The loss of lateral resolution for small apertures and wideband signals is also illustrated; an improvement is again observed in terms of the singular function concept.

Basic Theory of Radar Polarimetry

Wolfgang-M. Boerner
Electromagnetic Imaging Division
Communications Laboratory
Dept. of Electrical Engineering
& Computer Sciences
University of Illinois at Chicago
P. O. Box 4348
Chicago, Illinois 60680

A brief survey of basic theories for polarization utilization in radar target reconstruction is presented, and a general review of the various scatterer polarization transformation matrices and its invariants of the associated optimal matrix polarizations, and of the scatterer descriptive operators is introduced.

It is then shown how the five (5) independent matrix parameters for the relative phase monostatic scattering matrix describing an isolated, yet regionally distributed target in a reciprocal propagation medium can be recovered from (i) amplitude-only, (ii) mixed amplitude plus partial phase, (iii) complete two-step amplitude-phase measurements. Basic properties of the radar target scattering matrix for linear (H, V) and circular (R, L) polarization basis are described in terms of geometrical target features as functions of the specular point surface coordinate parameters, known as gaussian principal, main and related curvature functions. The theoretical part of the paper is concluded with the introduction of a transport equation formulation for precipitation clutter-wave interaction phenomena in the m-to-sub-mm wave region, utilizing properties of the partial theory of coherence.

The developed theories are verified by computer computation using measurement data and/or model scattering data as inputs.

Polarimetric Dependence of Residues in the
Radar Target Resonance Description

Vithal K.S. Mirmira and Wolfgang-M. Boerner
Electromagnetic Imaging Division
Communications Laboratory/SEL-4210
Department of Electrical Engineering
& Computer Science/SEO-1141
University of Illinois at Chicago
P.O. Box 4348 851 S. Morgan
Chicago, Illinois 60680

The singularity expansion method (SEM) is used to study the characteristic properties (e.g., estimates on material properties and shapes) of the scatterer.

We review the various fields where SEM and its counterparts are used to study such diverse effects as defects in solids (acoustics), interaction of elementary particles (Regge-pole theory) and radar target identification in electromagnetic scattering.

We conclude the review with an analysis of the polarization dependence on SEM: We specifically look at a gaussian pulse impinging on a thin wire, studying the polarization sensitivity of the residues associated with the eigenresonances.

THE STATE SPACE APPROACH TO THE DIRECT AND INVERSE
PROBLEMS IN LOSSY LAYERED MEDIA

C.Q. Lee, R. Shegetti, and M. Burns
Department of Electrical Engineering and Computer Science
University of Illinois at Chicago
Chicago, IL 60680

One of the difficulties often encountered in an inverse problem is the cumulative error resulting from experimental error and the round off effect in numerical calculations. There are many techniques of parameter estimation in fields other than inverse scattering which deal with similar situations using the state space approach. In order to apply these techniques to the inverse problem, the inverse algorithm must be organized into proper system equations.

In this paper, we present some theoretical results obtained from further study on the inverse technique developed recently for a lossy layered medium (C.Q. Lee Proc. IEEE, 70, 219-228, 1982). Using boundary conditions at each interface and the coupling between the incident and reflected waves in each layer, we develop a signal flow graph in the transform domain representing the wave propagation in the medium. From this signal flow graph, the mathematical basis of the direct and inverse problems can be described. Similar techniques have been used in the field of geophysics. Our model is very general and, under certain circumstances, can be simplified to those of special cases published previously.

We assume that the medium is divided into layers of equal one-way travel times, but that the propagation velocity is not necessary uniform. The back-scattering wave measured at the sending end boundary is the response of the layered medium and is served as input data for the inverse problem. Using the ray tracing technique, this wave can be decomposed into components of primary, secondary and tertiary reflections, etc. The concept is similar to the Bremmer series decomposition in the lossless case. The response of the layered medium so formulated can be used to facilitate the estimation and identification of the parameters in the inverse problem.

Vector Diffraction Tomography

Chau-Wing Yang and Wolfgang-M. Boerner
Electromagnetic Imaging Division
Communications Laboratory/SEL-4210
Department of Electrical Engineering
& Computer Science/SEO-1141
University of Illinois at Chicago
P.O. Box 4348 851 South Morgan
Chicago, Illinois 60680

The scalar theories of acoustic diffraction tomography have been developed for both the back-projection and the back-propagation methods, and have been further extended to the electromagnetic case taking the vector nature into account. Here, we consider electromagnetically inactive materials for which no depolarization will occur for the continuous inhomogeneous case; whereas, for the discontinuous heterogeneous case, depolarization of the incident electromagnetic wave may occur. For this letter case, it is assumed that a vector extended Born/Rytov approach can be applied, and examples are worked out for modelling the Faraday and the Kerr effect.

**FURTHER RESULTS ON WAVE EQUATIONS FOR
RADIATING AND NONRADIATING SOURCES, AND ON UNIQUENESS
FOR INVERSE SOURCE AND INVERSE SCATTERING PROBLEMS**

**W. Ross Stone, IRT Corporation
1446 Vista Claridad, La Jolla, CA 92037**

The author presented a paper at the January 1983 National Radio Science Meeting which derived two results: 1. The radiating portion of the source term ρ_R , in the inhomogeneous Helmholtz wave equation for the fields, itself satisfies an inhomogeneous Helmholtz wave equation; and 2. The nonradiating portion of the source term ρ_{NR} , satisfies a homogeneous wave equation. The derivation of these results, while rigorous, was not constructive in the sense that the physical meaning and the form of the source term for the wave equation for ρ_R was not determined. This paper presents the form of this source term and examines its physical implications. The physical implications of the allowable solutions to the wave equation for ρ_{NR} are also considered. In particular, it appears that, with proper constraints, the solutions to this classically-derived equation for nonradiating sources can be associated with quantum mechanical effects. These are related to results obtained by G. H. Goedecke (*Phys. Rev.*, 135, pp. 281-288, 1964) for classical, rigid, finite distributions of charge which undergo periodic motion and which are nonradiating. The existence of similar results for the radiating sources is explored. The question of the physical (vis-a-vis) mathematical realizability of nonradiating sources is examined in light of these results.

The analogue of a nonradiating source for the inverse medium problem is a nonscattering potential (or refractive index). It is known that such potentials exist for a single, monochromatic plane wave incident field. By contrast, it is also known that a potential is uniquely determined by the fields scattered by an infinite set of incident plane waves (see H. P. Baltes (ed.), *Inverse Source Problems in Optics*, Springer-Verlag, 1978, Chap. 3 and references therein for a discussion of these concepts). A very important practical case falls between these two extremes: Given a finite number (> 1) of incident plane waves, over what set of potentials can uniqueness be achieved? This question is investigated in light of the new results obtained above, and a relationship between spatial resolution and uniqueness is obtained. The consequences of this result for the inverse source problem are pointed out, in terms of obtaining at least a limitation on the set of nonradiating sources which can be associated with a set of scattering data.

A VECTOR INVERSE ALGORITHM FOR ELECTROMAGNETIC SCATTERING

Brett Borden
 Michelson Laboratory, Physics Division
 Naval Weapons Center, China Lake, CA 93555

We are investigating an inverse radar scattering technique that uses the polarization characteristics of the radar echo, along with a modest degree of Doppler processing, to form an image of the convex portions of the scattering body. The depolarization of a radar signal $\underline{E} = H_x \hat{i} + H_y \hat{j}$ by a scattering surface is related to the local principal curvatures K_x and K_y by the leading edge of the impulse response

$$RH_{pol} = \frac{1}{2\pi} \left(\frac{K_x - K_y}{2} \right) \frac{\partial S}{\partial t} [H_x \hat{i} - H_y \hat{j}] ,$$

where S is the illuminated surface area and R is the range. This equation provides a means by which the local curvature properties of the surface may be determined from the radar echo polarization. Furthermore, a classic problem in Differential Geometry (Christoffel-Hurwitz) deals with the reconstruction of such a surface from a knowledge of this kind of information, and a differential equation relating these local measurements to the surface has long been established:

$$r^2 \nabla^2 M(\theta, \phi) + 2M(\theta, \phi) = - \left(\frac{1}{K_x} + \frac{1}{K_y} \right)$$

(M is the spherical image of the convex scatterer). Unfortunately, its exact solution requires an exhaustive amount of input data, more than could be realized by any expected radar encounter. It is possible, however, to attack not the differential equation but the corresponding variational problem,

$$\delta \int \left[\left(\frac{\partial M}{\partial \theta} \right)^2 + \frac{1}{\sin^2 \theta} \left(\frac{\partial M}{\partial \phi} \right)^2 - 2M^2 - 2 \left(\frac{1}{K_x} + \frac{1}{K_y} \right) \right] \sin \theta d\theta d\phi = 0 ,$$

and thereby allow for a solution on a finite data set. In this way, a "solution" that best fits the known data can be found.

A Fortran code employing this "finite-element" inversion algorithm has been constructed and tested on synthetic data. The effect of perturbed or corrupted data on this algorithm has been investigated, as well as the extent to which the data set can be limited, and the technique has demonstrated an ability to reconstruct smooth convex bodies from a remarkably sparse data set. The problem of an aspect-limited data set will be discussed.

INVERSE ELECTROMAGNETIC SCATTERING FOR RADIALLY
INHOMOGENEOUS DIELECTRIC SPHERES

C. Eftimiu
McDonnell Douglas Research Laboratories
St. Louis, MO 63166

The problem of reconstructing the index of refraction of an electromagnetic target (assumed radially distributed) from scattering data is investigated.

To this end, the electromagnetic scattering amplitude is first analyzed in terms of two sets of phase-shifts. Knowledge of one of these phase-shifts, either as a function of (real) frequency or as a meromorphic function in the complex frequency plane, with (simple) poles at the natural frequencies of the target, is assumed. An analysis of the essential role played by the analytic properties in the frequency plane of the Jost-type solutions of the reduced radial equations shows that the quantum mechanical solution of the inverse scattering problem is not directly applicable to the electromagnetic inverse problem. To circumvent this difficulty, Liouville transformations are performed, leading from the radial equations for the electromagnetic problem to Schroedinger-like equations with frequency-independent potentials. The inverse quantum mechanical problem, consisting in the reconstruction of such potentials is then solved via the Marchenko formalism. Finally, the mathematical problem consisting of the reconstruction of the index of refraction from the reconstructed potentials is discussed.

URSI/B-4-1
INVERSE SCATTERING - II (APPLICATIONS)

102 - SW
Tuesday 1:30 - 5:00

CHAIRMAN: Ross W. Stone
IRT Corporation
La Jolla, CA 92037

1. (1:30) *MICROWAVE TOMOGRAPHIC AND PROJECTION IMAGING OF 3-D DIELECTRIC BODIES*, N. H. Farhat, D. Jaggard, T. H. Chu, D. B. Ge, S. Mankoff, University of Pennsylvania, Dept. of Electrical Eng. & Science, 200 S. 33rd Street, Philadelphia, PA 19104
2. (1:50) *A TWO-COMPONENT MODEL FOR INTERPRETING THE DOPPLER SPECTRUM OF A FORWARD-SCATTER DOPPLER RADAR SIGNAL*, Robert E. Post, Iowa State University, Dept. of Elec. Engineering, Ames, IA 50011
3. (2:10) *REMOTE TEMPERATURE SENSING BY MEANS OF ACTIVE MICROWAVE IMAGING*, J. Ch. Bolomey, L. Jofre, G. Peronnet, Laboratoire des Signaux & Systemes, Plateau du Moulon, 91190 Gif/Yvette, France
4. (2:30) *DECISION RULES DETERMINED FROM MODELS TO CLASSIFY COASTAL ZONE PARAMETERS USING MULTIPOLARIZATION SYNTHETIC APERTURE RADAR DATA*, Andrew J. Blanchard, Texas A&M University, Remote Sensing Center, College Station, TX 77843
5. (2:50) *A SCATTER MODEL FOR VEGETATION UP TO KU-BAND*, H. J. Eom, A. K. Fung, Uni. of Kansas Center for Research, Inc., Remote Sensing Laboratory, 2291 Irving Hill Drive - Campus West, Lawrence, KS 66045
6. (3:40) *OPTIMUM POLARIZATION FOR TARGET-CLUTTER DISCRIMINATION*, A. K. Fung, H. J. Eom, Uni. of Kansas Center for Research, Inc., Lawrence, KS 66045
7. (4:00) *MEASURES OF SAR IMAGE QUALITY*, Robert W. King, V. H. Kaupp, W. P. Waite, H. C. MacDonald, University of Arkansas, Dept. of Electrical Engineering, Fayetteville, AR 72701
8. (4:20) *ANALYSIS OF THE EFFECTS OF SIGNAL PROCESSING ON SAR IMAGES TO IMPROVE IMAGE FIDELITY*, N. D. Matthews, V. H. Kaupp, W. P. Waite, H. C. MacDonald, University of Arkansas, Dept. of Electrical Engineering, Fayetteville, AR 72701
9. (4:40) *DETERMINATION OF OPTIMUM STEREO RADAR PARAMETERS*, M. A. Fisaruck, V. H. Kaupp, H. C. MacDonald, W. P. Waite, University of Arkansas, Dept. of Electrical Engineering, Fayetteville, AR 72701

MICROWAVE TOMOGRAPHIC AND PROJECTION IMAGING OF 3-D DIELECTRIC BODIES

N.H. Farhat, D. Jaggard, T.H. Chu, D.B. Ge, and S. Mankoff
University of Pennsylvania
Electro-Optics and Microwave-Optics Laboratory
The Moore School of Electrical Engineering
200 S. 33rd Street
Philadelphia, Pennsylvania 19104

It is known from *inverse scattering theory* that multi-aspect monostatic or bistatic frequency response measurement of the far field scattered by a 3-D dielectric or conducting body under conditions that satisfy the *physical optics* and Born approximations can be used to access the Fourier space of the scatterer. Correction of the data collected in this fashion (by wavelength and angular diversity) for range-phase, and in practice for clutter and system response, yields knowledge of a finite region of the 3-D Fourier transform of the object *scattering function*. The scattering function can be viewed as representing the 3-D geometrical distribution and strengths of those scattering centers or differential scattering cross-sections of the body that give rise to the measured field. The size and shape of the accessed Fourier region depends on geometry and on the extent of the spectral and angular apertures utilized. Reconstruction of a *diffraction and noise limited* image of 3-D object detail can then be obtained by Fourier inversion of the acquired Fourier space data.

In this paper 3-D tomographic and projective reconstructions of dielectric bodies will be discussed. Results obtained from realistic data collected in our Experimental Microwave Imaging and Measurement facility in the (6 - 17) GHz range will be presented. Several simple dielectric test objects such as a slab, cylinder and pair of concentric cylinders have been utilized. The results demonstrate the feasibility of high resolution 3-D tomographic imaging of dielectrics for nondestructive evaluation (NDE) and metrology.

A TWO-COMPONENT MODEL FOR INTERPRETING THE DOPPLER SPECTRUM
OF A FORWARD-SCATTER DOPPLER RADAR SIGNAL

Robert E. Post
Department of Electrical Engineering and the
Engineering Research Institute
Iowa State University
Ames, Iowa 50011

Signals received on a forward scatter Doppler radar system contain significant information about the scattering mechanisms involved. Several scattering models have been proposed in the efforts to relate the scattered signals to the state of the atmosphere. Most of these scattering models can be expressed in terms of the Doppler spectrum of the scattered signals. The use of the forward scatter radar-Rake receiver systems to study the scattering process has been described by Birkemeier, et al., (Proceedings of IEEE, 57, 352-359, 1969).

In practice, the scattering models are fit to the Doppler spectrum of the received signal and, in the process, parameters of the atmosphere in the scattering volume are inferred. In many instances, the Doppler spectrum is characterized by a high amplitude narrow width peak centered on zero Doppler frequency. Birkemeier showed that the narrow width of the Doppler spectrum could be explained by introducing anisotropy in the scattering function.

A simplified scattering model, based on the anisotropic scattering model developed by Birkemeier and a Gaussian reflection function model introduced by Crawford, Hogg and Kummer, (BSTJ, 38, 1067-1178, 1959), has been developed by Post and Ibrahim, (IEEE Trans. AP, 30, 1240-1242, 1982). This model offers advantages in extracting the anisotropy coefficient from the Doppler spectrum of the received signal.

Efforts to measure the anisotropy of the scattering process by fitting the Birkemeier scattering model to the Doppler spectrum data often results in a poor fit. This is particularly true when the zero Doppler peak is very narrow. Under these conditions, a superposition of two Gaussian-shaped functions results in a composite two-component model that fits the observed Doppler frequency data quite well. One Gaussian curve is fit, in a least squares sense, to the data in the neighborhood of the zero Doppler peak and the other Gaussian model is fit, in a least squares sense, to the rest of the data. The composite model is developed by adding the powers of the two Gaussian models at each data point and matching the zero Doppler power of the composite model to the zero Doppler data.

Examples of the application of the two-component model to describe the Doppler spectrum of signals taken from the forward scatter radar-Rake receiver system operated on a cooperative basis by Iowa State University and the University of Wisconsin are presented and discussed.

REMOTE TEMPERATURE SENSING BY
MEANS OF ACTIVE MICROWAVE IMAGING (*)

J.Ch. BOLOMEY, L. JOFRE, G.PERONNET
Groupe d'Electromagnétisme
Laboratoire des Signaux et Systèmes
Ecole Supérieure d'Electricité
Plateau du Moulon - 91190 Gif/Yvette - France

This communication is devoted to the possible use of active microwave imaging for remote temperature sensing. Such a possibility results from the temperature dependence of the complex permittivity of the objects to be observed.

Active microwave tomography (J.Ch. Bolomey et al., Microwave diffraction tomography for biomedical applications, to be published in IEEE-MTT Transactions, Nov. 1982) allows the reconstruction of the equivalent currents which are related to the complex permittivity. Microwave images can then be interpreted in terms of temperature from a more or less straight forward manner.

Some basic experiments conducted in water at 3 GHz illustrate the temperature sensitivity as well as the spatial resolution capabilities of this imaging process. Its limitations are discussed in view of applications to microwave heating in biomedical (hyperthermia) or industrial domains. The discussion includes a comparison with classical microwave thermography.

(*) Sponsored by DGRST [TLB 81.M.0909], in collaboration with Société d'Etude du Radant (Orsay) and Laboratoire de Thermologie Biomédicale (Strasbourg).

DECISION RULES DETERMINED FROM MODELS TO CLASSIFY
COASTAL ZONE PARAMETERS USING MULTIPOLARIZATION
SYNTHETIC APERTURE RADAR DATA

by
Andrew J. Blanchard
Remote Sensing Center
and Electrical Engineering Department
Texas A&M University
College Station, Texas 77843

The use of microwave imagery in geological and agricultural applications has been of interest to researchers in recent years. Both multifrequency and multipolarization data have been used to extract information about soil saturation, surface roughness, vegetation parameters, etc. Many of these studies especially in geologic applications have relied on conventional photo interpretive and/or image processing techniques with somewhat encouraging results. Recent progress in the understanding of the interaction processes that govern microwave backscatter from earth/land targets, especially regarding depolarization effects, has improved the image interpretation decision making technique. This paper presents the results of a recent study of coastal zone areas using multipolarization, multifrequency imaging radar data. The results are unique in that the classification scheme used in the image analysis incorporated the results of theoretical models which describe microwave backscatter from earth/land targets. Specifically those models which deal with depolarization effects were used.

Using theoretical models we were able to identify the information content available in the microwave data. With some prior knowledge of the characteristics of the area of investigation we designed a series of models to determine the general microwave system response. The decision rules for image classification were designed using model performance. Consideration of incidence angle, polarization and some antenna system effects were made. The results were compared for accuracy to previously ground truthed classifications.

A SCATTER MODEL FOR VEGETATION UP TO KU-BAND

H.J. Eom and A.K. Fung

Remote Sensing Laboratory
University of Kansas Center for Research, Inc.
Lawrence, Kansas 66045

ABSTRACT

A scatter model is developed based on the matrix doubling method for volume scattering and the Kirchhoff method in rough surface scattering. Scattering from vegetation is assumed to be dominated by leaves and a single leaf is modeled by a thin dielectric disc. In developing the phase matrix for the disc field within the disc is taken to be constant over the disc thickness but phase changes across the surface of the disc are accounted for. Comparisons of this scatter model with radar measurements indicate good agreements in polarization, angular trends and frequency up to Ku-band. This represents a considerable improvement over low frequency scatter models which are valid up to S-band.

OPTIMUM POLARIZATION FOR
TARGET-CLUTTER DISCRIMINATION

A.K. Fung and H.J. Eom

Remote Sensing Laboratory
University of Kansas Center for Research, Inc.
Lawrence, Kansas 66045

Abstract

When a target is situated against a background such as a snow field or vegetation, it is of interest to determine the optimum polarization which will enhance the average power returned from the target relative to that returned from the background. In this study an algorithm developed by Ioannidis and Hammers (1979) and another one by Kennaugh (1952) are used to compute the optimum polarizations for an assumed target situated in a snow field. The dependence of the optimum polarizations on the look angle is also illustrated. The snow field scatter properties are represented by a Mueller matrix derived by Fung and Eom (1982).

Measures of SAR Image Quality

Robert W. King

Verne H. Kaupp, Associate Professor

William P. Waite, Professor
Department of Electrical Engineering

H. C. MacDonald, Professor
Department of Geology

University of Arkansas
Fayetteville, Arkansas 72701

Abstract

Despite more than a century of investigation, no satisfactory and universally accepted metrics have been devised that characterize the quality of photographic images. Each of us has the inherent ability to rank order images according to some internal scale which we conceive to represent relative image quality. Virtually all investigations of image quality have concentrated upon images of scenes illuminated by incoherent radiation, i.e., primarily visible light. The noise component in such images is additive; that is, the signal recorded for each point (picture element or pixel) in the scene is the sum of the point illumination intensity signal plus the noise encountered in the image forming and recording process for each pixel. Most of the existing image metrics are defined in terms of this additive signal to noise relationship because the superposition principle involved often simplifies the computations.

For synthetic aperture radar this relationship is altered because the scene illumination is a single coherent radiation source - the transmitter. In this situation, the signal and noise components are multiplicative increasing by orders of magnitude the dynamic range of noise intensities. Further, both the geometric distortions in the image introduced by having the illumination source co-located with the imaging aperture and the use of time discrimination as opposed to photography's angular discrimination to position the information returned from a scene within the image, also influence the characteristics of radar imagery. These factors suggest that the image metrics investigated in the past for conventional (incoherent) imagery be re-investigated in the context of imagery from imaging radars.

Quality metrics from previous analyses of incoherent imaging systems are re-investigated for their applicability to the specific SAR problem. Sample imagery has been produced via the powerful SAR simulation program developed at the University of Arkansas. This imagery and associated results are presented.

ANALYSIS OF THE EFFECTS OF SIGNAL PROCESSING
ON SAR IMAGES TO IMPROVE IMAGE FIDELITY

NORMAN DANIEL MATTHEWS
VERNE H. KAUPF, ASSOCIATE PROFESSOR
W.P. WAITE, PROFESSOR
DEPARTMENT OF ELECTRICAL ENGINEERING
H.C. MACDONALD, PROFESSOR
DEPARTMENT OF GEOLOGY

UNIVERSITY OF ARKANSAS
FAYETTEVILLE, ARKANSAS 72701

ABSTRACT

In the past, attempts have been made to present the final output of a Synthetic Aperture Radar(SAR) processed image in a form that accentuates geologic features. By examining the effects induced by varying the signal weighting on the output, geomorphic features of the scene can be enhanced with the appropriate selection of variables.

It is found that signal weighting significantly affects the presentation of the geomorphic information in the scene. By examining its effect coupled with the effects of dynamic range and incidence angle presentation of the data, the best presentation of the geomorphic information can be provided. Several images will be used and minute variations in signal output will be provided in order to trace the effects of varying a particular parameter of the simulated SAR image.

DETERMINATION OF OPTIMUM STEREO RADAR PARAMETERS

Michael A. Pisaruck
Research Associate
Verne H. Kaupp
Associate Professor of Electrical Engineering
Harold C. MacDonald
Professor of Geology
William P. Waite
Professor of Electrical Engineering

University of Arkansas
Fayetteville, Arkansas 72701

ABSTRACT

In the past, stereo radar imagery has been evaluated and compared with its photographic equivalent by use of the vertical exaggeration factor (q). This metric for the comparison of stereo images has been adapted from the field of photogrammetry and has proven useful for this purpose. It is believed, however, that q is not the best measure of stereo radar image quality. It has the inherent limitation that it is subjective in both its original definition and its present use. Also, the results to be reported here indicate that q varies widely among image pairs judged to be the best by image-interpreters, and that it is not a reliable predictor of overall stereo radar image quality.

Computer simulated radar images were evaluated by trained image interpreters and rank-ordered on a basis of information content and ease of interpretation. The simulated imagery covers low relief, moderate relief, and high relief areas; and the angles of incidence used to create the stereo pairs varied from small to intermediate to large. Same-side stereo was used because it gave acceptable stereo pairs for each of the terrain types used.

The results thus far indicate that a more reliable predictor of which image pairs a geologic image interpreter would pick as best is the amount of parallax present in the stereo pair. Experimental data will be presented which compare the vertical exaggeration and parallax values for the image pairs picked as best by the interpreters. Results of statistical analyses that examine the trends of such variables as parallax, exaggeration factor, angles of incidence, and stereo intersection angle will be given. Examples of the simulated SAR images used in the analysis will be shown. In addition, equations will be given to calculate the relative height differences in radar imagery from measurements of parallax.

URSI/B-4-2
NUMERICAL METHODS - II

Auditorium 2 - AH
Tuesday 1:30 - 3:10

CHAIRMAN: Daniel Schaubert
Department of Electrical
and Computer Engineering
University of Massachusetts
Amherst, MA 01003

1. (1:30) *AN ANALYSIS OF A 2-D DIELECTRIC COVERED CORRUGATED FEED HORN*, R. Nevels, M. Overly, Texas A&M University, Dept. of Elec. Eng., College Station, TX 77843
2. (1:50) *ACCELERATION OF PERIODIC GREEN'S FUNCTIONS IN FREE SPACE*, William F. Richards, J. R. Zinecker, University of Houston, Dept. of Electrical Engineering, Houston, TX 77004, Donald R. Wilton, S. Singh, University of Mississippi, Dept. of Electrical Engineering, University, MS 38677, Y. T. Lo, S. Wright, University of Illinois, Dept. of Electrical Engineering, Urbana, IL 61801
3. (2:10) *APPLICATION OF SERIES ACCELERATION TECHNIQUES TO PROBLEMS INVOLVING PERIODIC MEDIA*, D. R. Wilton, S. Singh, The University of Mississippi, Dept. of Electrical Engineering, University, MS 38677, W. F. Richards, University of Houston, Dept. of Electrical Engineering, Houston, TX 77004
4. (2:30) *EFFICIENT EVALUATION OF THE PERIODIC GREEN'S FUNCTION FOR A GROUNDED DIELECTRIC SUBSTRATE*, S. M. Wright, Y. T. Lo, University of Illinois, Dept. of Electrical Engineering, Urbana, IL 61801, W. F. Richards, J. R. Zinecker, University of Houston, Dept. of Electrical Engineering, Houston, TX 77004
5. (2:50) *SCATTERING CURRENT ON A CIRCULAR, TUBULAR, PERFECTLY CONDUCTING CYLINDER OF FINITE LENGTH*, Hung-Mou Lee, Naval Postgraduate School, Dept. of Electrical Engineering, Monterey, CA 93940

AN ANALYSIS OF A 2-D DIELECTRIC COVERED
CORRUGATED FEED HORN

R. Nevels and M. Overly
Department of Electrical Engineering
Texas A&M University
College Station, Texas 77843

In this paper we present an investigation of the dielectric covered corrugated horn with a semiflare angle of 90° . The corrugated horn has become a very popular feed mechanism for the parabolic dish antenna. Such feeds have the advantages of wide beamwidth and low cross-polarization performance over a wide frequency band. A corrugated horn with a semiflare angle of 90° is perhaps the most popular feed for the parabolic dish used in the home satellite TV receiver industry. In order to produce antennas which are both light and economical the feed is constructed of aluminum. However aluminum has a tendency to corrode during year round exposure to the elements. In order to prevent corrosion which results in degradation of the antenna operating characteristics, the active portion of the feed is covered by a cap made of a dielectric material such as polyethylene. The dielectric cap when properly designed may also prove to be a useful impedance matching device.

Since the difficulties in dealing with the cylindrical geometry of the feed device are great we decided to test our technique by first analyzing the two dimensional case. A parallel plate waveguide operating in the TEM mode opens into a ground plane containing a finite set of notches and covered by a dielectric slab. Expressions for the magnetic fields are found in the parallel plate waveguide, in the notches and in the slab covering the ground plane. Each of the magnetic fields is found in terms of the tangential electric field in the parallel plate and notch apertures. The coupled integral equations obtained by requiring continuity of magnetic field in the apertures are solved by the Method of Moments numerical technique. Far field patterns and parallel-plate guide input impedance are presented as a function of slab thickness.

ACCELERATION OF PERIODIC GREEN'S FUNCTIONS IN FREE SPACE

W. F. Richards, J. R. Zinecker, University of Houston, Houston, TX 77004
D. R. Wilton, S. Singh, University of Mississippi, University, MS 38677
Y. T. Lo, S. Wright, University of Illinois, Urbana, IL 61801

This paper addresses the problem of the **efficient** computation of the electromagnetic fields due to infinite, planar, periodic arrays of point electric and magnetic dipoles in free space. This work has direct application to the numerical analysis of periodic structures including phased arrays, polarizers, dichroic surfaces, spatial and temporal filters, and artificial dielectrics. It is also extendable to the problem of computing the fields due to arrays of point dipoles in the presence of dielectric strata. This has important application for arrays of microstrip antennas, particularly those used at millimeter waves which have been typically periodic and very large.

The spectral and spatial representations of the magnetic vector potential are well known. These are infinite series in two indices which are very slowly converging when the field observation point is in the plane of the dipoles. In this paper, we present a method of summing the spectral representation of the vector potential that is much more efficient than computing either the spectral sum or the direct spatial sum. This method uses a "Kummer's transformation" coupled with an application of the Poisson summation formula. The original spectral sum with a summand of $f(m,n)$ is first written as the sum of $f(m,n) - g(m,n)$ over all pairs of integers, (m,n) , plus the sum of $g(m,n)$ alone. The function $f(m,n)$ is asymptotic to $g(m,n)$ as $|m|$ and $|n|$ increase without bound. The first sum involving $f - g$ converges faster than the original sum. The second sum involving g alone is accelerated by the Poisson summation formula which replaces the sum of $g(m,n)$ by the sum of $G(2\pi m, 2\pi n)$ where G is the Fourier transform of g with respect to m and n . To ensure that the transform, G , is a highly peaked function so that its series has improved convergence properties, g must be chosen very carefully. The formulas for the accelerated series and a comparison of the computational effort involved in summing them to that required for the ordinary spectral and spatial series will be presented. We also will present the results of the application of another acceleration technique (Shank's transformation) used in conjunction with the method described above.

APPLICATION OF SERIES ACCELERATION TECHNIQUES
TO PROBLEMS INVOLVING PERIODIC MEDIA:

D. R. Wilton and S. Singh, University of
Mississippi, University, MS 38677 and
W. F. Richards, University of Houston,
Houston, TX 77004

The high cost of developing computer codes for determining the electromagnetic radiation and scattering characteristics of specific geometries has lead engineers increasingly to employ, where possible, general purpose computer codes capable of treating whole classes of geometries. Such computer codes usually employ integral equation formulations of problems which are solved by the method of moments. In order to achieve the degree of generality required, it is usually necessary to employ subsectionally-defined basis functions to represent unknown quantities such as surface currents or fields. Little progress has been made, however, in adapting these principles to the development of general purpose computer codes for treating problems involving periodic geometries or media. This is primarily due to the poor computational efficiency which results from direct summation of series representing Green's functions associated with such problems. Usually engineers must either pay a high cost for the computation, or must employ entire domain basis functions appropriate to the geometry to represent the unknown so as to enhance the convergence at the expense of generality.

In a companion paper, methods are discussed for alleviating this problem by significantly accelerating the convergence of series representations of the Green's function. It is shown there that appropriate Kummer's transformations, in some cases followed by an application of Shanks' transformation, may be used to effectively accelerate the series computation. In this paper these acceleration methods are applied to periodic problems involving simple wire structures solved by the method of moments. In such problems, the series is further transformed by integration against the basis and testing functions used in forming the matrix elements. Of particular note is that the form of Kummer's transformation used explicitly exhibits the $1/R$ singularity in the kernel which may be isolated for separate numerical treatment by standard techniques. Representative computational results are presented and questions relating accuracy of the matrix elements to accuracy of currents determined from them are considered.

EFFICIENT EVALUATION OF THE PERIODIC GREEN'S FUNCTION
FOR A GROUNDED DIELECTRIC SUBSTRATE

S.M. Wright and Y.T. Lo
Department of Electrical Engineering
University of Illinois
Urbana, Illinois 61801

W.F. Richards and J.R. Zinecker
Department of Electrical Engineering
University of Houston
Houston, Texas 77004

It is well known that the plane wave spectrum approach allows one to express the fields of an arbitrary source as a superposition of plane waves. Munk and Eurell [AP-27, no. 3, May 1979] used this technique to find the field of an infinite periodic array of point sources, in particular with the array adjacent to a dielectric substrate. Unfortunately, this infinite summation of plane waves can be very slowly convergent. This paper discusses the acceleration of such a series for the magnetic vector potential of an infinite periodic array of point sources over a grounded dielectric substrate.

The method of acceleration used is discussed in detail in a companion paper [Richards *et. al.*, Proc. URSI Symp., May 23-26, 1983]. Basically, this technique involves finding an asymptotic approximation for the original expression which is smooth everywhere, having no discontinuities or singularities. Kummer's transformation of series is then used to accelerate the summation, using the Poisson summation formula to find the sum of the terms in the asymptotic approximation.

We present results showing the savings in computer time this method provides over the direct spectral summation. For array dimensions and substrates typically found in microstrip arrays, savings when computing the potential to one percent accuracy are typically greater than two orders of magnitude, even for observation points tenths of a wavelength from the nearest source. The savings increase as one requires greater accuracy or approaches a source. In addition, the effect of several parameters, such as substrate thickness, beam scan angle, and observation point will be discussed. Other applications of the results will also be discussed.

SCATTERING CURRENT ON A CIRCULAR, TUBULAR,
PERFECTLY CONDUCTING CYLINDER OF FINITE LENGTH

Hung-Mou Lee
Department of Electrical Engineering
Naval Postgraduate School
Monterey, CA 93940

On a tubular cylinder of finite length, the coupled integrodifferential equations for the two components of the total surface current distribution excited by an incident field are given by the Stratton-Chu equations. The axial dependence of the kernel of the integrodifferential equations is expanded as a double series on a complete set of orthogonal functions. The expansion coefficients are given explicitly as power series of the smaller of the two geometrical dimensions of the cylinder: When the diameter of the cylinder is smaller than its length, the coefficients are given in power series of the square of the diameter of the cylinder; When the length of the cylinder is smaller than its diameter, the coefficients are given in power series of the square of the length of the cylinder.

Surface current distributions are obtained for both types of cylinders by computing their expansion coefficients on the same set of orthogonal functions used for the expansion of the kernel. A straight wire and a circular loop are well known examples modeled as the two extreme cases of a finite, circular, tubular cylinder.

URSI/B-4-3
SCATTERING

Auditorium 2 - AH
Tuesday 3:20 - 5:00

CHAIRMAN: P. H. Pathak
Electroscience Laboratory
Ohio State University
1320 Kinnear Road
Columbus, OH 43212

1. (3:20) *PLANE WAVE DIFFRACTION BY A DIELECTRIC COATED LOSSY CONDUCTOR*, M. Dahleh, R. Nevels, L. Tsang, Texas A&M University, Dept. of Elec. Eng., College Station, TX 77843
2. (3:40) *SCATTERING CALCULATIONS ACROSS A FREQUENCY BAND VIA THE SPECTRAL-ITERATIVE TECHNIQUE*, M. Hurst, Raj Mitra, University of Illinois, Electrical Engineering Dept., 1406 W. Green, Urbana, IL 61801
3. (4:00) *ELECTROMAGNETIC SCATTERING AND RADAR SIGNATURES FROM CONICAL GRAUPEL*, K. Aydin, T. A. Seliga, The Ohio State University, Atmos. Sci. Program & Dept. of Elec. Eng., 2015 Neil Avenue, Columbus, OH 43210, V. N. Bringi, Colorado State University, Dept. of Elec. Engr., Fort Collins, CO 80523
4. (4:20) *ELECTROMAGNETIC SCATTERING BY THREE DIMENSIONAL DIELECTRIC OBJECTS*, Korada Umashankar, A. Taflove, IIT Research Institute, 10 West 35th Street, Chicago, IL 60616, S. M. Rao, Rochester Institute of Technology, Rochester, NY 14623
5. (4:40) *A SECOND KIND FREDHOLM EQUATION FROM THE ELECTRIC FIELD INTEGRAL EQUATION*, W. A. Davis, Virginia Poly. Inst. & State University, Dept. of Elec. Engr., Blacksburg, VA 24061

PLANE WAVE DIFFRACTION BY A DIELECTRIC COATED
LOSSY CONDUCTOR

M. Dahleh, R. Nevels and L. Tsang
Department of Electrical Engineering
Texas A&M University
College Station, Texas 77843

A study of scattering of TE polarized electromagnetic plane wave by a periodic lossy conductor covered by a dielectric coating is presented (see figure below). At optical frequencies dielectrics are used to coat diffraction gratings so as to prevent damage to the grating. However it has been observed that a Wood's anomaly attributed to the production of surface waves is much more evident when a diffraction grating is covered by a dielectric coating. This anomalous behavior may prove to be an advantage at microwave frequencies by allowing energy to be more efficiently coupled into a surface wave.

The method of solution is based on the extended boundary condition principle. Green's theorem is used to formulate the problem in terms of an integral equation. By applying the extended boundary condition we obtain simple matrix equations which are solved numerically. The extended boundary condition approach yields an exact theoretical solution. An advantage of this approach is that it is general and can be applied to a wide variety of periodic configurations. Results are presented in terms of the efficiency (defined as the ratio of the transmitted energy to the incident energy) for different structural parameters such as period (p), grating height (h) and dielectric thickness (t) as a function of angle of incidence.

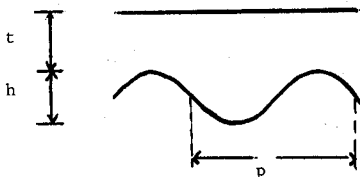

SCATTERING CALCULATIONS ACROSS A FREQUENCY BAND VIA
THE SPECTRAL-ITERATIVE TECHNIQUE

M. Hurst and R. Mittra
Electrical Engineering Department
University of Illinois
Urbana, Illinois

The stacked two-dimensional Spectral-Iterative Technique (SIT) recently introduced by Kastner and Mittra ["A Spectral-Iteration Technique for Analyzing Scattering from Arbitrary Bodies," to be published] is an efficient method for numerically calculating scattering from arbitrary bodies. In this method, the current on a body is sampled at a series of parallel planes. At each step in the iteration process, the approximate current distribution at a particular plane is modified such that the boundary conditions are satisfied at that plane when fields due to the (approximate) currents elsewhere in the body are taken into account. The calculation of fields from the induced currents is done in the spectral domain because all necessary operations are algebraic there. In this paper, improvements to SIT will be reported which do away with the requirement that the scattering body fit a rectangular grid which would result in faster convergence. Examples of E-wave scattering from conducting cylinders will be given, with comparisons to results from other methods (GTD and the moment method). For the important application of calculating scattering from a body across a frequency band, SIT will be shown to be especially useful because the iterative nature of this method allows one to take advantage of the fact that the current distribution at one frequency will serve as an excellent starting approximation for the distribution at an adjacent frequency. A procedure for extending the method to inhomogeneous dielectric bodies and three-dimensional bodies will also be included in the paper.

ELECTROMAGNETIC SCATTERING AND RADAR SIGNATURES
FROM CONICAL GRAUPEL

K. Aydin and T. A. Seliga
Atmospheric Sciences Program and
Department of Electrical Engineering
The Ohio State University
Columbus, Ohio 43210

V. N. Bringi
Department of Electrical Engineering
Colorado State University
Fort Collins, Colorado 80523

A cone with an oblate spheroid base has been used as a model for the shape of conical graupel. The backscattering cross sections (σ_H , σ_V), circular depolarization ratios (CDR) and differential reflectivities (Z_{DR}) were computed for equivolume diameters up to 26 mm for three cone angles (70° , 80° , 90°) and two values of the axial ratio of the oblate spheroidal base (0.5 and 0.75). Both wet and dry spongy graupel were considered. The Z_{DR} of dry graupel varies between 0 to 1.2 dB and CDR is between -60 to -25 dB. On the other hand, when the graupel is wet, Z_{DR} ranges between -1.0 to +8.0 dB and CDR between -40 dB to -10 dB. The increase of water within the ice structure enhances all of the signals (σ_H , σ_V , Z_{DR} and CDR). The effect of the shape on Z_{DR} is mainly related to the ratio of the maximum horizontal to the maximum vertical dimensions (the same is true for CDR in this model).

ELECTROMAGNETIC SCATTERING BY THREE DIMENSIONAL DIELECTRIC OBJECTS

K. Umashankar and A. Taflove
IIT Research Institute
10 West 35th Street
Chicago, Illinois 60616

and

S. M. Rao
Rochester Institute of Technology
Rochester, New York 14623

Three dimensional electromagnetic scattering problems have been difficult to treat with either analytical and/or numerical methods because of the complicating effects of the scattering geometry. To gain insight into scattering mechanisms using analytical and numerical approaches, generally canonical structures are studied rather than realistic models. Two potential alternate approaches which may permit highly realistic modeling of dielectric scattering problems are the finite-difference time-domain (FD-TD) method and the method of moments (MOM) triangular surface patch technique.

This paper will briefly review recent development and extension of the method of moment technique for modeling of three dimensional dielectric scattering problems based on combined field formulation and triangular surface patches. Numerical results are presented for two canonical three dimensional dielectric scatterers-- a sphere and a cube. The magnitude and phase of the induced equivalent electric and magnetic currents on surface of the dielectric scatterers are obtained for an external plane wave excitation. The MOM results are compared with respect to the latest FD-TD results for dielectric scatterers. The corresponding far field patterns are also obtained.

By comparing the results of MOM and FD-TD, and the computational resources needed for each method, it is hoped that the range of usefulness of each technique can be better defined. In particular, the range of the scatterer electrical size and the ability of each method to successfully model the physics of wave interaction are key points of comparison discussed in this paper.

A SECOND KIND FREDHOLM EQUATION FROM THE ELECTRIC
FIELD INTEGRAL EQUATION

W. A. Davis

Department of Electrical Engineering
Virginia Polytechnic Institute and State University
Blacksburg, VA 24061

There has been much discussion in the last decade regarding singular integral equations in electromagnetics, particularly the electric field integral equation (EFIE). Most researchers have found the EFIE to provide good solutions as long as the singularity is properly handled. The typical approach to the latter is to extract the singularity for analytical treatment with the remainder handled numerically (V. I. Krylov, Approximate Calculation of Integrals, 1962). The remaining difficulty of boundary conditions for surfaces (not wires) may be handled by shifting the expansion grids (A. W. Glisson, Jr., Ph.D. dissertation, 1978).

This paper presents a technique of converting the above first kind Fredholm equation (EFIE) to a second kind equation. As above, the singularity is first extracted. The inverse of the singular part is then taken to give a resultant second kind equation. The wire antenna will be used to demonstrate the technique. It is particularly interesting to note that the logarithmic singularity in the current associated with delta gaps of wires is immediately apparent in this process. The remaining smooth integral gives rise to the forced antenna current resulting from the feed voltage and capacitance. The resultant second kind equation is also amenable to standard Fredholm theory and thus proofs regarding solution, particularly of an SEM nature.

JOINT APS/URSI
PLENARY SESSION

Auditorium 1 - AH
Wednesday 8:30 - 12:00

CHAIRMAN: William E. Gordon
President
International Union of Radio Science
Rice University
Houston, TX 77001

(8:30) *Introduction and Welcome*

1. (8:40) *RECENT DEVELOPMENTS IN WELL LOGGING TECHNIQUES*, John D. Ingram, Vice President of Schlumberger Well Services, P.O. Box 2175, Houston, TX 77001
2. (9:20) *POSITRON EMISSION TOMOGRAPHY: A MAGIC OF TECHNOLOGY AND MEDICINE*, K. Lance Gould, Director of the Cardiology Division, University of Texas School of Medicine, P.O. Box 20708, Houston, TX 77025
3. (10:30) *PROGRESSIVE WAVE AND OSCILLATORY FORMULATIONS OF PROPAGATION AND SCATTERING*, Leopold B. Felsen, Polytechnic Institute of New York, Route 110, Farmingdale, NY 11735
4. (11:10) *THE SPACE SHUTTLE - PAST, PRESENT, AND FUTURE*, Bonnie J. Dunbar, Mission Specialist Astronaut, NASA - Johnson Space Center, Code CB, Houston, TX 77056

URSI/B-6-1
ANTENNAS

Auditorium 1 - AH
Wednesday 1:30 - 5:00

CHAIRMAN: Gary Thiele
University of Dayton
Dayton, OH 45469

1. (1:30) *USE OF THE SIMPLEX METHOD FOR MICROWAVE PROBLEMS: A COMPUTER AIDED DESIGN TECHNIQUE*, R. Blau, Raytheon Co. Missile Systems Division, Hartwell Road, Bedford, MA 01730
2. (1:50) *SIDELobe LIMITATIONS FOR A PARABOLIC REFLECTOR WITH A MOVABLE ARRAY FEED*, H. Steyskal, M. O'Brien, R. Shore, Rome Air Development Center, Electromagnetic Sciences Division, Antennas & RF Components Branch, Hanscom Air Force Base, MA 01731
3. (2:10) *A DIGITAL BEAMFORMING ARRAY*, John F. Rose, J. M. Loomis, US Army Missile Command, DRSMI-RER, Bldg 5400, Redstone Arsenal, AL 35896
4. (2:30) *WAVE CONTRIBUTIONS TO THE ELEMENT PATTERN OF A CYLINDRICAL ARRAY SURROUNDED BY A DIELECTRIC RADOME*, A. E. Fathy, A. Hessel, Polytechnic Institute of New York, Dept. of Elec. Eng. & Computer Science, Route 110, Farmingdale, NY 11735
5. (2:50) *A MODERATE GAIN ELECTRONICALLY STEERABLE S-BAND ARRAY FOR ORBITER - TDRS APPLICATION*, W. A. Lewton, J. R. Carl, NASA, Lyndon B. Johnson Space Center, Houston, TX 77058
6. (3:40) *DUAL-FREQUENCY MICROSTRIP ANTENNAS*, Y. T. Lo, C. E. Skupien, S. S. Zhong, University of Illinois, Dept. of Elec. Engr., 1406 W. Green St., Urbana, IL 61801, W. F. Richards, University of Houston, Dept. of Elec. Engr., 4800 Calhoun St., Houston, TX 77004
7. (4:00) *THE ADMITTANCE OF AN INFINITELY LONG INSULATED MONOPOLE ANTENNA DRIVEN BY A COAXIAL CABLE*, Eric M. Gurrola, Sandia National Laboratories, Albuquerque, NM 87185
8. (4:20) *ECCENTRICALLY INSULATED ANTENNA THEORY APPLIED TO BEVERAGE ANTENNA*, R. S. Kasevich, D. B. Odom, R. D. Throne, Raytheon Company, Wayland, MA 01778
9. (4:40) *A PRECISION TROPOSCATTER ANTENNA ALIGNMENT TECHNIQUE*, Ashok K. Gupta, The Catholic University of America, Washington, D.C. 20064

USE OF THE SIMPLEX METHOD FOR MICROWAVE PROBLEMS:

A COMPUTER AIDED DESIGN

TECHNIQUE

Robert Blau
Raytheon Company
Bedford, Massachusetts

ABSTRACT

The simplex method of linear programming, which has long been used for the solution of economics and business management problems, is also useful for the solution of diverse types of microwave problems. The simplex method uses a minimum of computer time, requires no matrix inversion, and always produces a global minimum in a finite number of steps. The challenge is to discover how to express a given design problem in linear form. Once this is done, the results are usually swift and dramatic.

In this paper, the simplex method is applied to the redesign of an X-band phased array antenna. The method provides an immediate improvement of 20 dB in the worst side-lobes without sacrificing any other antenna characteristics such as beamwidth or shape factor. The computer program used to do this work is remarkably short and simple. Copies are available upon request.

SIDELOBE LIMITATIONS FOR A PARABOLIC REFLECTOR
WITH A MOVABLE ARRAY FEED

H. Steyskal, M. O'Brien, R. Shore
Electromagnetic Sciences Division
Rome Air Development Center, Hanscom AFB, MA 01731

Limited scan techniques continue to draw interest for many applications. One well known antenna configuration consists of a paraboloidal reflector with a small planar array feed. Beam steering is achieved by moving the feed off axis, while beam distortion is kept low through control of the complex array excitation. However, the problem of what the pattern sidelobe limitations are for the case of a given antenna configuration, a given scan angle and a variable feed array excitation has not been addressed and forms the basis of this paper.

Two methods to determine a suitable feed excitation have been proposed. The first (R.N. Assaly, L.J. Ricardi, IEEE Trans. AP-14, 601-605, 1966; G. Chadwick, IEEE/APS Symp. Digest, 350-353, 1982) is based on reciprocity and can be described as a focal region field match. The second method (R. Tang et al, AFCRL-TR-75-0448, Aug 1975) synthesizes the desired aperture illumination at a number of sampling points with the aid of a multiple beam feed array.

In this paper we compare the above two competing methods from the point of applicability, ease of implementation, and capability to produce low sidelobe antenna patterns. In addition, we consider the perturbation of the desired feed excitation caused by mutual coupling effects in a realistic array feed and its consequences for the antenna pattern.

A Digital Beamforming Array

J. F. Rose, J. M. Loomis

US Army Missile Command

ABSTRACT

An eight element Digital Beamforming (DBF) array is described. The array has the capability of forming flexible multiple simultaneous beams by converting the RF amplitude and phase of each element to a digital format followed by beamforming in a general purpose computer. The subassemblies necessary at each element for downconversion and amplification were measured in terms of phase and amplitude matching between elements. Antenna pattern data was gathered and a variety of antenna patterns are presented. Analysis is performed on the patterns to quantify the errors. These errors are compared to the errors measured on the subassemblies to verify the error effects.

WAVE CONTRIBUTIONS TO THE ELEMENT PATTERN
OF A CYLINDRICAL ARRAY SURROUNDED BY
A DIELECTRIC RADOME*

A. E. Fathy and A. Hessel
Polytechnic Institute of New York
Route 110
Farmingdale, New York 11735

High frequency asymptotic analysis is presented for circumferentially polarized far field radiated by an excited element in a two-dimensional cylindrical phased array surrounded by a dielectric sleeve radome.

The effects of the curved radome manifest themselves in pronounced dips and in an off broadside ripple of a potentially considerable amplitude.

In contrast to the previous work (Hessel-Sureau, IEEE Trans. on A-P, AP-21, 159-164, 1973) the analysis clarifies the role of different guided wave contributions in formation of the element pattern in a curved array environment, by comparing the asymptotic and modal results.

A Moderate Gain Electronically Steerable
S-Band Array for Orbiter - TDRS Application

W. A. Lewton and J. R. Carl

A sixteen element, flush mounted, electronically steerable array is being developed for possible application to Orbiter - TDRS telecommunication links. Four such antennas would be placed symmetrically around the circumference of the Orbiter body. Antenna switching and beam steering would be automatically controlled based on ephemeral information from the on-board computers.

The individual radiating elements are closely spaced square spirals in a four by four square Matrix. The boresight beamwidth is 24 degrees at the center of the operating band. The antenna bandwidth is 1700 to 2500 MHz. The design goal for gain/coverage is +6 dBi over 85 percent of a sphere.

Dual-Frequency Microstrip Antennas

Y. T. Lo, C. E. Skupien, S. S. Zhong
University of Illinois

and

W. F. Richards
University of Houston

Thin microstrip antennas have remarkably compact structure; but they are inherently narrow-banded. To extend their usefulness, the possibility of multiple-frequency operation is often speculated. Some workers have considered a design for dual frequency operation by using actually two patch antennas of different dimensions and interconnected with transmission lines, while others made use of an elaborate microstrip line circuit in an ad hoc fashion for achieving a certain dual-frequency operation. In both cases the unique and attractive feature of compactness of microstrip antennas is compromised.

Obviously, it is highly desirable to have a new design such that a single patch with only one simple feed can be made to operate for two or more discrete bands. This kind of element would find many important applications. For example, for large arrays, they would not only make possible a significant saving in material but also in space and weight, which often are a major problem in space-borne systems.

In this investigation two approaches have been studied, both theoretically and experimentally, in an attempt to achieve that goal. The first investigation is made on annular microstrip antennas. As seen from the cavity model theory, an antenna of this type, if excited for (1,1), (1,2), and (1,3) modes, will all have predominantly broadside radiation of the same polarization. However, unlike disc or rectangular patches, the resonant frequencies for these modes are not of fixed ratios, being dependent on the dimensions of the inner and outer radii. Sets of curves and tables which show this dependence are presented. In addition, the feeding methods and techniques for suppressing undesirable modes are discussed. For most microstrip antennas, such as disc and rectangle, the computed resonant frequency from the cavity model theory is always higher than the measured, due to the fringing field effect. However for annulus, this may not be true since it has two unconnected boundaries. This is also investigated in some detail.

In the second approach, a rectangular patch, excited particularly in the (0,1) and (0,3) modes, is investigated since they both produce broadside radiations of the same polarization. However, the operating frequencies for these modes are at a fixed ratio, approximately 3:1. To remove this restriction, electrically shorting pins are inserted along the modal lines in the (0,3) modal field in the patch. In so doing, the frequency of the (0,1) mode can be varied over a wide range while that of the (0,3) mode is kept unchanged. The frequency variation with the number of pins is tabulated. For the pins investigated so far, the ratio of the two frequencies can be changed from 1.8 to 3. The effect of shorting pins can be predicted with good accuracy by the multipoint theory.

THE ADMITTANCE OF AN INFINITELY LONG INSULATED
MONOPOLE ANTENNA DRIVEN BY A COAXIAL CABLE

Eric M. Gurrola
Electromagnetic Environments Analysis
Division 7553
Sandia National Laboratories
Albuquerque, New Mexico 87185

The common methods of analyzing linear antennas treat the antenna separately from its driving transmission line and use mathematically simple drives such as delta-function generators. However, in an accurate analysis it is necessary to include the interaction between the field produced by the antenna and the transmission line. A rigorous solution for an infinitely long uninsulated monopole antenna driven by a coaxial cable has been investigated (Wu, J. Math. Phys., Vol. 3, 1298-1301, 1962) and numerically evaluated (Morris, SAND 78-1065, 1978). Numerous other papers investigating uninsulated antennas have ensued.

In this paper the admittance of an infinitely long insulated monopole antenna driven by a coaxial cable is investigated. The problem is reduced to solving a single Fredholm integral equation of the first kind with a singular kernel for the electric field in the gap at the drive to the antenna. The integral equation is investigated in the limit that the surrounding medium is a perfect conductor and in the limit that the surrounding medium, the antenna insulation and the coaxial cable insulation are the same material. Both of these limits are checked against other existing theories. Finally, the numerical techniques necessary to solve the integral equation in the low frequency limit are discussed.

ECCENTRICALLY INSULATED ANTENNA THEORY APPLIED TO BEVERAGE ANTENNA:
R.S. Kasevich, D.B. Odom, and R.D. Throne, Raytheon Company, Wayland, MA 01778,
1983

The Beverage antenna finds application as an element in Beverage arrays used for direction finding and communications. Some development work has been performed on Beverage antennas to meet the requirement of a highly directional, over-the-horizon (OTH) bistatic radar receiving antenna.

Of interest in the intended application is the low elevation angle space wave radiation characteristics of the Beverage wave antenna where the contribution from the horizontal wire current is negligible as compared to the ground induced current contribution. The theory of the eccentrically insulated wire antenna has been developed by R.W.P. King, T.T. Wu and L.C. Shen (Radio Sci., 9, 701-709, 1974.), to describe the properties of the horizontal wire closely coupled to a generally lossy media. The theory shows that the wire current induces a surface image electric field at the air-ground interface which is the source of the ground scattered field. Treating this surface image as an equivalent aperture of magnetic current, the far-field is evaluated. Results indicate that significant radiation is possible at very low elevation angles where the contribution from the horizontal wire current is negligible.

Numerical results and comparisons with available data are presented. An experimental program has been designed to specifically measure and evaluate the radiation field contribution from the surface image source and the wire contribution for a range of elevation angles. The initial measurements are planned at ranges from 10 to 50 kilometers, to be followed by a second series at OTH ranges.

A PRECISION TROPOSCATTER ANTENNA ALIGNMENT TECHNIQUE

Ashok K. Gupta
The Catholic University of America
Washington, D.C. 20064

The present paper relates to methods for determining the degree of misalignment of the transmitting and the receiving antenna beams in a radio link operating through a time-variant scatter mechanism, based entirely on the difference in signal-to-noise ratio (or error probability) of the two binary alphabets that such misalignment will cause in the received alphabets introduced by the time-variant scatter mechanism. Analytical results for frequency-shift keying using incoherent detection to the cases of complex exponential and Gaussian fading correlation functions show that, for identical transmitter and receiver frequencies, the difference is proportional to the antenna misalignment. Such results can also be obtained for differentially coherent matched filter receiver for binary data transmission except for DPSK signalling, where binary symmetric operation exists for all fading correlation functions. For unequal transmitter and receiver frequencies, the received signal may be first spectrally-shifted in time domain and then the difference is computed.

Presently known alignment technique based on maximizing the received signal power has serious shortcoming because of deep persistent fading. Another prior-art technique based on cross-correlating the cophasal and quadrature components of the received doppler-spread signal requires a sophisticated hardware. The alignment technique based on third central spectral moment of the received complex envelope requires time differentiation, which is highly sensitive to the noise.

URSI/B-6-2
GUIDED WAVES

Auditorium 2 - AH
Wednesday 1:50 - 5:00

CHAIRMAN: Edward F. Kuester
Electromagnetics Laboratory
Department of Electrical Engineering
University of Colorado
Boulder, CO 80309

1. (1:50) *STRONG POLARIZATION CONVERSION IN RADIATION FROM SURFACE WAVES INCIDENT OBLIQUELY ON A GROOVED DIELECTRIC LAYER*, M. J. Shiau, S. T. Peng, A. A. Oliner, Polytechnic Institute of New York, 333 Jay Street, Brooklyn, NY 11201
2. (2:10) *METHOD OF ANALYSIS FOR NONUNIFORM DIELECTRIC WAVEGUIDES*, S. T. Peng, Polytechnic Institute of New York, Brooklyn, NY 11201, F. Schwering, U. S. Army, CECOM, Ft. Monmouth, NJ 07703
3. (2:30) *HAMILTONIAN THEORY OF COUPLED GRADIENT-INDEX (SLAB) FIBERS*, Walter K. Kahn, George Washington University, Dept. of Elec. Eng. & Computer Sci., Washington, D.C. 20052
4. (2:50) *ASYMPTOTIC THEORY OF ANISOTROPIC OPTICAL FIBERS*, I. V. Lindell, M. I. Oksanen, Helsinki University of Technology, Dept. of Elec. Engr., Radio Lab., Otakaari 5A, Espoo 15, 02150 Finland
5. (3:40) *ON IMPROVING THE NUMERICAL ACCURACY AND THE CONVERGENCE IN DIELECTRIC STEP DISCONTINUITY PROBLEMS*, Mikio Tsuji, Hiroshi Shigesawa, Doshisha University, Dept. of Electronics, Karasuma-Imadegawa, Kamikyo-ku, Kyoto, 602 Japan
6. (4:00) *DETERMINATION OF CONSTITUTIVE PARAMETERS FOR A LOSSY DISPERSIVE BIAXIAL MATERIAL*, N. J. Damaskos, R. B. Mack, W. Parmon, N.J.D.I., P. O. Box 469, Concordville, PA 19331, A. L. Maffett, University of Michigan at Dearborn, Dept. of Mathematics, Dearborn, MI, P. L. E. Uslenghi, University of Illinois at Chicago, Dept. of Electrical Eng. & Computer Sci., P. O. Box 4348, Chicago, IL 60680
7. (4:20) *THE VALIDITY OF THE LOSSLESS APPROXIMATION IN THE ANALYSIS OF TRANSMISSION LINE COUPLING*, Robert G. Olsen, Washington State University, Electrical Engr. Dept., Pullman, WA 99164-2210
8. (4:40) *A DISCUSSION ON THE SPATIAL GREEN'S FUNCTION FOR MICROSTRIP LINE*, Y. L. Chow, M. N. Tutt, University of Waterloo, Electrical Engr. Dept., Waterloo, Ontario, Canada N2L 3G1

STRONG POLARIZATION CONVERSION IN RADIATION FROM
SURFACE WAVES INCIDENT OBLIQUELY ON A
GROOVED DIELECTRIC LAYER

M. J. Shiau, S. T. Peng and A. A. Oliner
Polytechnic Institute of New York
333 Jay Street
Brooklyn, NY 11201

We have previously studied the effects produced when a surface wave is incident obliquely on a periodically-grooved dielectric layer, and have found a variety of interesting physical phenomena, such as mode conversion, extra stop bands, anisotropy, radiation at skew angles, etc. We were particularly interested in radiation phenomena as applied to leaky antennas, and we concentrated on the eigenvalue problem, yielding the phase and leakage constants needed for antenna design. Here, we extend the study to include the eigenvector problem in order to examine the radiation fields themselves, with particular stress on the polarization content.

When the surface wave incidence is oblique, the resulting guided wave (and radiation) becomes hybrid, with both TE and TM content. The degree of polarization conversion in the radiation depends on the deviation of the incidence angle from normal, at which extreme there is no polarization conversion at all. One of the conclusions from the present study is that under appropriate conditions, a surprisingly large amount of polarization conversion occurs even for relatively small deviations from normal incidence; for example, for TM surface wave incidence at an angle of 17.5° from the normal, we found 94% of the total radiated power is converted to the opposite polarization. Both rigorous and approximate methods of analysis have been carried out and will be included in the presentation.

METHOD OF ANALYSIS FOR NONUNIFORM DIELECTRIC WAVEGUIDES

S. T. Peng
Polytechnic Institute of New York
Brooklyn, New York 11201

F. Schwering
U. S. Army, CECOM
Ft. Monmouth, New Jersey 07703

It has been recognized that dielectric structures for use as waveguides and antennas are very attractive for the design of millimeter-wave systems, particularly at the high frequency end of the spectrum. Although uniform dielectric waveguides for use as individual circuit components have been extensively studied in recent years, wave phenomena associated with nonuniform dielectric waveguides remain to be systematically investigated and understood so that circuit components, devices, and antennas can be optimally interconnected to form a millimeter-wave system.

In this work, we utilize the approach of generalized transmission-line equations for the analysis of nonuniform dielectric waveguides. The generalized transmission-line equations are casted in a form that is convenient for the application of an iteration procedure. We first establish a sufficient condition for the convergence of the iteration procedure. Simple analytic formula are then constructed for physical interpretations of wave phenomena associated with nonuniform dielectric waveguides and also for practical design considerations. The results are compared with those previously obtained by other methods, as will be discussed in the talk.

HAMILTONIAN THEORY OF COUPLED
GRADIENT-INDEX (SLAB) FIBERS

Walter K. Kahn

Department of Electrical Engineering & Computer Science
School of Engineering and Applied Science
George Washington University, Washington, D.C. 20052

The operator formalism of quantum mechanics provides an elegant approach to problems associated with the propagation of beams in gradient-index multimode optical fibers via the formal analogy with Hamiltonian Optics which obtains when the time is replaced by the axial coordinate in the fiber. As the potential function corresponds to variation in the refractive index, techniques developed in connection with the harmonic oscillator become available for solution of the optical fiber. In particular coherent states are recognized as beam modes. The phenomena associated with a system of coupled harmonic oscillators, more varied in the quantum mechanical than in the classical regime, have interesting optical counterparts.

Coupling between a system of two gradient index (slab) fibers is analysed. It is shown that in such a system the oscillations about the fiber axis which result when a beam is injected eccentrically can be substantially suppressed.

Numerical results are presented for two identical truncated quadratic index (slab) fibers.

ASYMPTOTIC THEORY OF
ANISOTROPIC OPTICAL FIBERS

I.V.Lindell, M.I.Oksanen
Helsinki University of Technology, Radio Laboratory,
Otakaari 5A, Espoo 15, 02150 Finland

The problem of weakly guiding dielectric waveguide with transversely anisotropic material is considered in this paper. It is shown that when the difference in the dielectric tensor components is a vanishing quantity, the field satisfies asymptotically a differential equation of the vector Schrödinger equation type. The solution is only dependent on the form of the guide and its anisotropic profile. Because the equation is of the standard eigenvalue equation, the Rayleigh quotient functional can be applied for an approximate solution of the propagation constant and field function for the basic modes. The isotropic fiber is a degenerate special case of the problem and in fact more difficult to solve. It is easily demonstrated that the birefringence (difference in propagation properties of two orthogonally polarized basic modes) of the isotropic guide is asymptotically of a smaller order than that of the anisotropic guide.

The method is tested for the well-known isotropic step-index guide and new results are calculated for two types of anisotropic guides: one with an isotropic cladding and anisotropic core and the other with both cladding and core anisotropic.

ON IMPROVING THE NUMERICAL ACCURACY AND THE CONVERGENCE
IN DIELECTRIC STEP DISCONTINUITY PROBLEMS

Mikio Tsuji and Hiroshi Shigesawa
Department of Electronics, Doshisha University
Kamikyo-ku, Kyoto, 602 Japan

Partially corrugated dielectric slabs can be treated by considering a cascaded connection of step discontinuities, each of them is intrinsically a "generalized network", having a finite number of discrete ports (the surface waves), plus a continuum of ports (the continuous spectrum). When a surface wave is incident at an arbitrary angle to a step, coupling between TE and TM modes occurs. Under such a situation, a cascaded connection of a number of steps is successfully analyzed when and only when the noticeable accuracy and the good convergence are obtained for both TE and TM discontinuity problems at each step.

Now, a continuous spectrum comprises both the radiation part within a finite range of the continuum of modes and the reactive part representing localized energy storage. In a usual discontinuity, however, most energy of an incident surface wave couples strongly to a continuum of modes in a limited narrow range within the radiation part. When such a spectrum is expanded into the Gauss-Laguerre functions as seen in published papers, one always suffers from convergence difficulty, because such functions are "good functions" in the entire range of the continuous spectrum.

To avoid this difficulty, we divide the continuous spectrum into three ranges: one corresponds to the radiation part, the second is an optimally scaled extent of the reactive part, and the third, disregarded here, is the rest of the reactive part. Then an appropriate complete set of basis functions in each range is provided by the normalized Legendre functions. This approach, together with the mode matching method in the least-squares sense, is applied for investigating the TM case as well as the TE case.

Numerical results are shown to demonstrate the rapid convergence as well as the noticeable accuracy. A typical result, calculated for a moderate step at the junction of two monomode slabs, shows that a few number of Legendre functions result in 99.999% and 99.99% in the power conservation, for the TE case and the TM case, respectively.

DETERMINATION OF CONSTITUTIVE PARAMETERS
FOR A LOSSY DISPERSIVE BIAXIAL MATERIAL

N.J. Damaskos, R.B. Mack, W. Parmon
N.J.D.I., Box 469, Concordville, PA 19331

A.L. Maffett
Department of Mathematics
The University of Michigan at Dearborn

P.L.E. Uslenghi
Department of Electrical Engineering and Computer Science
University of Illinois at Chicago

An anisotropic material whose permittivity tensor $\underline{\epsilon}$ and permeability tensor $\underline{\mu}$ are represented by 3×3 matrices with zero off-diagonal elements in an (x, y, z) coordinate system is considered. The three diagonal elements of each matrix are different from one another and are in general, complex and frequency-dependent. We wish to determine all six parameters by measuring reflection and transmission coefficients when slabs of the material are inserted in a rectangular waveguide.

Firstly, we prove that, contrary to a published statement, an isolated TE_{n0} mode can exist in a biaxial medium and is sufficient to satisfy the boundary conditions in the waveguide. Secondly, the six parameters are uniquely related to amplitude and phase of reflection and transmission coefficients for the TE_{10} and TE_{20} modes at a specified frequency, and for three different orientations of the sample. Thirdly, the measurement set-up is described and experimental results are discussed. The setup consists of a network analyzer and of a known fixture which permits the separate excitation of the TE_{10} and TE_{20} modes in the same guide (see e.g. Sucher and Fox, Handbook of Microwave Measurements, vol. 1, p. 327).

"THE VALIDITY OF THE LOSSLESS APPROXIMATION IN THE ANALYSIS
OF TRANSMISSION LINE COUPLING"

Robert G. Olsen
Electrical Engineering Department
Washington State University
Pullman, WA 99164-2210

Using the reciprocity theorem, a formula is derived which can be used to calculate the coupling between two lossy parallel wires of finite length above a perfectly conducting plane. One wire is driven by a voltage source while the other is not. Both wires are terminated at each end by arbitrary impedances. Weak coupling is assumed.

The formula is used to examine the conditions under which the lossiness of the wires is important by comparing it to the corresponding lossless formula. Based on this comparison comments will be made about the design of directional couplers and about coupling between power lines and parallel wires. Finally, the formula is used to provide a better model for understanding the results of a recent coupled transmission line experiment (C.R. Paul, IEEE Trans. Electromagnetic Compatibility 24, 335-344, 1982).

A DISCUSSION ON THE SPATIAL GREEN'S FUNCTION FOR MICROSTRIP LINE

Y.L. Chow and M.N. Tutt
Electrical Engineering Department
University of Waterloo
Waterloo, Ontario, Canada. N2L 3G1

The approximate spatial Green's functions for microstrip structures have been constructed and shown to give accurate results (Chow and El-Behery MTT-26, 978-983, 1978; Chow, MTT-28, 393-397, 1980; Fang and Chow, J.Ap.Phy.54(1), 1983). While there are two Green's functions, one for the magnetic current and the other for electric current for the narrow microstrip line only the latter is important. For the latter, this paper gives a rigorous justification on its validity and also gives a physical interpretation on its dispersive effect in terms of the distributed capacitance and inductance of the microstrip line.

The rigorous justification of the validity of the approximate electric current Green's function, is obtained by identifying the images of approximate spatial Green's function with the image terms of the exact spectral Green's function (J.A. Kong, Theory of Electromagnetic Waves, John Wiley and Sons, 1975, pp.215-227). With such identification, it can be shown that the approximate spatial Green's function (with modifications) can be applied not only to short distances ($\ll \lambda/8$) as previously assumed, but also to long distances including radiation and surface wave regions.

Being simple and spatial, the approximate Green's function is easily interpreted. For example, by simple addition of the terms of the approximate Green's function along a straight microstrip line, the distributed capacitance, and inductance of the microstrip line can be obtained. The capacitance and inductance have different frequency dispersions. This difference is readily interpreted when one realizes that in the model of the approximate Green's function, there are more images for the charge, forming the capacitance, than the images for current, forming the inductance. The square root of the capacitance times the inductance gives of course the reciprocal of the velocity of propagation with the correct dispersion. The correct dispersion is taken from Itoh and Mittra (MTT-21, 496-499, 1973).

URSI/B-6-3
DIELECTRIC BODIES

101 - AH
Wednesday 1:30 - 5:00

CHAIRMAN: Akira Ishimaru
Department of Electrical Engineering
University of Washington
Seattle, WA 98195

1. (1:30) *INTERACTION OF THE NEAR-ZONE FIELDS OF AN APERTURE SOURCE ON A CONDUCTING SPHERE WITH A LOSSY DIELECTRIC SPHERE*, Shi-Guo Zhu, Huey-Ru Chuang, Kun-Mu Chen, Michigan State University, Dept. of Electrical Eng. & Systems Sci., East Lansing, MI 48824
2. (1:50) *MAGNETIC AND ELECTRIC FIELD EQUATIONS FOR LOSSY SURFACES*, R. K. Riit, Illinois State University, Dept. of Mathematics, Normal, IL 61761
3. (2:10) *COMPLEX RESISTIVITY OF DISSEMINATED SPHEROIDAL ORE GRAINS WITH NON CONFOCAL IMPEDANCE INTERFACE*, James R. Wait, Peter W. Flanagan, University of Arizona, Dept. of Elec. Eng. & Geosciences, Tucson, AZ 85721
4. (2:30) *ELECTROMAGNETIC SCATTERING BY IMPEDANCE BODIES OF REVOLUTION*, R. D. Graglia, P. L. E. Uslenghi, University of Illinois at Chicago, Dept. of Elec. Engr. & Computer Science, P.O. Box 4348, Chicago, IL 60680
5. (2:50) *INTEGRAL EQUATIONS FOR ANISOTROPIC SCATTERERS*, R. D. Graglia, P. L. E. Uslenghi, University of Illinois at Chicago, Dept. of Electrical Eng. & Computer Sci., P. O. Box 4348, Chicago, IL 60680
6. (3:40) *SURFACE POLARITON MODES*, Thomas B. A. Senior, The University of Michigan, Dept. of Electrical & Computer Eng., Ann Arbor, MI 48109
7. (4:00) *ELECTROMAGNETIC FIELDS IN CYLINDRICALLY STRATIFIED ROTATING MEDIA*, V. G. Daniele, CESPÀ - Politecnico di Torino, Italy, P. L. E. Uslenghi, University of Illinois at Chicago, Dept. of Elec. Engr. & Computer Science, P.O. Box 4348, Chicago, IL 60680
8. (4:20) *SCATTERING BY A LOSSY DIELECTRIC AND MAGNETIC BODY OF ARBITRARY CROSS-SECTION*, Juang-Lu Lin, Boeing Aerospace Company, P. O. Box 3999, Mail Stop 8W-04, Seattle, WA 98124
9. (4:40) *THE SURFACE FIELDS ON AN ABSORBING CIRCULAR CYLINDER OF LARGE RADIUS*, P. Langlois, Université de Provence, Dept. de Radioélectricité, Rue H. Poincaré, 13 397 Marseille, Cedex 13, France, A. Boivin, Université Laval, Dept. de Physique, Ste-Foy, Canada, G1K 7P4

INTERACTION OF THE NEAR-ZONE FIELDS OF AN APERTURE SOURCE ON A CONDUCTING SPHERE WITH A LOSSY DIELECTRIC SPHERE

Shi-Guo Zhu, Huey-Ru Chuang and Kun-Mu Chen
Dept. of Electrical Engineering and Systems Science
Michigan State University, E. Lansing, Mich. 48824

The interaction between the near-zone fields of an aperture source on a metallic structure with a closely located lossy dielectric body is an important topic in many areas including bioelectromagnetic area. This is a difficult problem to analyze because of the complexity of the near-zone fields and the close coupling between the body and the source.

In this study, we consider the geometry of a lossy dielectric sphere placed near a slot source on a conducting sphere. This geometry idealizes the situation of a man exposing to the leakage field of a microwave oven. The spherical geometries were adapted to obtain an exact solution to the problem. With an exact solution, it is possible to accurately estimate the coupling effect between the body and the source. It is also possible to establish the upper bound of error caused by neglecting the body-source coupling, a common approximation used in most of existing studies on the subject.

Assuming that the center of the conducting sphere with radius a is located at the origin O of the spherical (R, θ, ϕ) coordinates, and a slot with a sinusoidal field is located on the spherical surface at $(a, \theta_0, -\alpha < \phi < \alpha)$. Another spherical (R', θ', ϕ') coordinate system is assigned to describe the geometry of the dielectric sphere of radius b , with its origin O' coincides with the center of the dielectric sphere. Between these two coordinate systems, $\theta=0$ line coincides with $\theta'=\pi$ line and the distance between O and O' is R_0 .

The following iterative steps are used to solve the problem:

- (1) Determine the near-zone fields (\vec{E} and \vec{H}) of the slot in terms of vector spherical wave functions in (R, θ, ϕ) coordinates.
- (2) Translate these fields into (R', θ', ϕ') coordinates, using the addition theorem, to give the incident field to the dielectric sphere.
- (3) Determine the internal field of and the scattered field by the dielectric sphere maintained by this incident field.
- (4) Translate the scattered field by the dielectric sphere into (R, θ, ϕ) coordinates to give the incident field to the conducting sphere.
- (5) The scattered field by the conducting sphere caused by this incident field is determined.
- (6) The scattered field by the conducting sphere can be translated back to (R', θ', ϕ') coordinates to give the "second-round" incident field to the dielectric sphere.
- (7) The steps of (3) to (6) are repeated until the sums of partial fields converge.

The final solutions for the internal field in the dielectric sphere and the total external field of the system are then obtained. The body-source coupling is examined.

Magnetic and Electric Field Equations for Lossy Surfaces

R.K. Ritt Illinois State University

Let S be a closed and bounded surface. Let $(\underline{E}, \underline{H})$ be a time dependent electromagnetic field in the exterior of S , generated by the singular current $\underline{S}(x - x_0) \delta(t) p$. Let \underline{n} be the unit outward normal on S , and the field satisfies the boundary condition $\underline{E}_{\text{tan}} = \gamma(\underline{n} \times \underline{H})$, $\text{Re } \gamma \leq 0$. It is then possible to show that for $\text{Re } s > 0$, if $\underline{J}(\underline{y}, s)$ is the Laplace transform, on S , of $\underline{n} \times \underline{H}$, then

$$M) \left[\frac{1}{2} I + A \right] \underline{J} + \gamma B(\underline{n} \times \underline{J}) = -\underline{n}(\underline{y}) \times [\nabla_{\underline{y}} U(\underline{y}, x_0) \times p], \text{ and}$$

$$E) \quad B \underline{J} - \gamma \left[\frac{1}{2} I + A \right] (\underline{n} \times \underline{J}) = \underline{n}(\underline{y}) \times [s^{-1}(s^2 + \nabla_{\underline{y}} \nabla_{\underline{y}} \cdot) U(\underline{y}, x_0) p]$$

where $U(x, y) = (4\pi |x - y|)^{-1} \exp(-s|x - y|)$, and A and B are the well known operators:

$$A \underline{F} = \underline{n}(\underline{y}) \times \iint_S \nabla_{\underline{y}} U(\underline{y}, x) \times \underline{F}(x) dS_x,$$

$$B \underline{F} = \underline{n}(\underline{y}) \times [s^{-1}(s^2 + \nabla_{\underline{y}} \nabla_{\underline{y}} \cdot) \iint_S U(\underline{y}, x) \underline{F}(x) dS_x,$$

whenever \underline{F} is in the tangent field on S . For $\gamma = 0$, M) and E) are the usual magnetic and electric field equations for perfectly conducting surfaces. Since, under the hypotheses, the Laplace transforms of \underline{E} and \underline{H} can be shown to be square integrable in the exterior region, the derivations of M) and E) are easily obtained by manipulation of the Fourier transforms of these Laplace transforms. The solution of M) and E), for very small and very large values of $|\gamma|$, are discussed, and the effect of small changes in γ upon the characteristic frequencies of S is derived.

COMPLEX RESISTIVITY OF DISSEMINATED SPHEROIDAL ORE GRAINS WITH NON CONFOCAL IMPEDANCE INTERFACE

James R. Wait and Peter W. Flanagan
Depts. of Electrical Engineering and Geosciences
University of Arizona, Tucson, AZ 85721

We deal with the model of a mineralized ore zone in the form of a dissemination of metal particles of spheroidal shape. Electrochemical effects are fully accounted for by allowing the particles to exhibit an interface impedance that can have any variation of its complex value as a function of frequency. A quasi static analysis is employed which is justified because the particles are small in terms of the internal wavelength. A complication arises because the outer electrochemical layer, which is being modelled by the interface impedance, is not really confocal with the spheroid geometry. This causes the angular potential functions of order m to be coupled with those of order n which leads to an infinite set of equations to solve for the unknown coefficients. In a somewhat artificial manner this coupling can be eliminated by taking the electrochemical coating to be confocal in such a manner that the interface impedance is proportional to the metric coefficient in the spheroidal coordinates. While this approach gives some insight, it does not really solve the physical problem. Thus the purpose of this analysis is to allow for the influence of the interface impedance at the particle boundary which does not vary in any special manner as a function of the angular coordinates. The question of how to truncate the infinite set of equations is dealt with and various error criteria are established. It appears that the coupling plays a major role in any quantitative description of the induced polarization response of the electrolyte host region when it is loaded with non-spherical metal particles. The results are also relevant to biological systems where there is a change of conduction mode between different phases of the region.
[J. R. Wait, Gerlands Beitrage für Geophysik, vol. 92, no 2, 1983]

Electromagnetic Scattering by Impedance
Bodies of Revolution

R.D. Graglia and P.L.E. Uslenghi
Department of Electrical Engineering and Computer Science
University of Illinois at Chicago

A plane electromagnetic wave is axially incident on a rotationally symmetric scatterer, on whose surface an impedance boundary condition holds. The generalized Maue integral equation for the surface current density is manipulated analytically and then solved numerically for a scatterer of arbitrary profile.

Amplitude and phase of the two components of the surface current density are displayed and discussed for a variety of shapes (sphere, cone-sphere, cone-cylinder-sphere, etc.), for different frequencies and for several values of the relative surface impedance. The role of the relative surface impedance in modifying the surface current is discussed in detail.

Our computer program is precise well into the high-frequency range, as is evidenced by comparing our numerical results with the known exact results for a perfectly conducting sphere of radius a , for $ka = 10$. The program is also capable of reproducing the expected field behavior near singularities (tips and edges).

INTEGRAL EQUATIONS FOR ANISOTROPIC SCATTERERS

R.D. Graglia and P.L.E. Uslenghi

Department of Electrical Engineering and Computer Science
University of Illinois at Chicago

Integral equations for scatterers whose constitutive parameters (conductivity, permittivity and permeability) are homogeneous but anisotropic are derived, both in the time domain and in the frequency domain. No limitations are imposed on the form of the tensors $\underline{\sigma}$, $\underline{\epsilon}$, and $\underline{\mu}$.

The numerical solution of these equations is discussed for a variety of cases: scatterer made of one anisotropic material only, layered structures with different anisotropies in each layer, anisotropic layer coating a perfect conductor.

Numerical results are given for some simple two- and three-dimensional structures involving uniaxial, biaxial and gyrotropic media. Whenever possible, these results are compared with existing solutions, both exact and asymptotic. Applications, such as in microstrip substrates, are discussed.

SURFACE POLARITON MODES

Thomas B.A. Senior

Department of Electrical and Computer Engineering
The University of Michigan, Ann Arbor, MI 48109

For a homogeneous isotropic dielectric body of small electrical size, a low frequency approach may be adequate to approximate the scattered field. The leading (Rayleigh) term in the far field expansion is attributable to an induced electric dipole whose moment can be expressed in terms of the electric polarizability tensor, and the tensor elements then serve to specify the scattering and absorption cross sections to the lowest order in the wave number k . If $\text{Re } \epsilon_r > 0$

where ϵ_r is the relative permittivity of the body, the elements are relatively insensitive to the precise details of the body's shape, and it may be sufficient to replace the body by a simpler one such as a spheroid (T.B.A. Senior and H. Weil, Appl. Phys B29 (117) 1982), but if $\text{Re } \epsilon_r < 0$ this is not in general true.

Many common materials have molecular resonances in the infrared and optical frequency regions, and some interesting effects are seen when we examine Rayleigh scattering over a frequency band that includes a bulk resonance of the material. In the vicinity of such a resonance, $\text{Re } \epsilon_r < 0$. It is found that the body shape now has a critical effect on the absorption, shifting the frequency at which the absorption line or peak recur, and splitting it into many lines. The resonances are of two distinct types and are generally attributed to volume and surface polariton modes in the body (see, for example, D. Langbein, J. Phys. A9 (627) 1976).

The purpose of this paper is to examine the excitation and properties of surface polariton modes at low frequencies. Using the program DIELCOM (T.B.A. Senior and T. M. Willis, IEEE Trans. AP-30 (1271) 1982) developed to solve the electrostatic problem for a homogeneous, rotationally symmetric body of otherwise arbitrary shape, the excitation is explored by progressive deformation of a spheroid. At a value of $\text{Re } \epsilon_r (< 0)$ for which a mode is excited, the field inside (and in the immediate vicinity of) the body is determined, and its properties related to the geometry.

Electromagnetic Fields in Cylindrically
Stratified Rotating Media

V.G. Daniele
CESPA, Politecnico di Torino, Italy

and

P.L.E. Uslenghi
Department of Electrical Engineering and Computer Science
University of Illinois at Chicago

We consider a cylindrically symmetric structure consisting of coaxial layers of different materials (each characterized by permittivity, permeability and conductivity) rotating about the common symmetry axis with different angular velocities. This type of structure is important in a variety of applications, such as electromechanical energy conversion.

Under the assumption of velocities small with respect to the velocity of light, we express the transverse electric and magnetic fields as functions of the axial components E_z and H_z , which are solutions of two coupled differential equations. A Fourier transform with respect to the z -coordinate, followed by a Fourier series expansion with respect to the azimuthal ϕ -coordinate, reduces these differential equations to those encountered in the scattering by a parabolic cylinder. Thus, the most general fields which exist in the bianisotropic media considered herein can be expressed in terms of parabolic cylinder functions.

In the particular case of purely transversal fields, i.e., of fields independent of the z -coordinate, our results reduce to those obtained previously by Tai and Van Bladel.

SCATTERING BY A LOSSY DIELECTRIC AND MAGNETIC
BODY OF ARBITRARY CROSS-SECTION

Juang-Lu Lin
Boeing Aerospace Company
P.O. Box 3999, Mail Stop 8W-04
Seattle, Washington 98124

Scattering by a two-dimensional lossy dielectric and magnetic body of an arbitrary cross-section is investigated numerically and experimentally for both E and H polarized incident waves. Application of super-position and duality principles results in coupled integral equations for the unknown electric and magnetic field intensities within the body material. Following the conventional method of moments technique, the entire body is divided into electrically small cells such that the integral equations can be converted into a set of linear equations by pulse expansion and point matching at the center of each cell. The radar cross sections are then computed based on the scattered fields maintained by the fields within the body material. To check the accuracy of the results, computations on the echo area are compared with either the exact solutions or measurements. The technique presented here has been found useful in modification of the scattering pattern of a metallic object by changing the parameters of the material layers covering the conductor.

THE SURFACE FIELDS ON AN ABSORBING CIRCULAR CYLINDER OF LARGE RADIUS

P. LANGLOIS and A. BOIVIN

Groupe d'Optique Diffractionnelle, Antennes et Holographie GODAH/
LROL, Département de Physique, Université Laval, Ste-Foy, Canada
GIK 7P4.

The exact expression of the surface fields on a circular cylinder is known since Lord Rayleigh. It is given by an infinite series of eigenfunctions. However it is also well known that when the radius of the cylinder is much greater than the wavelength, the convergence of these series is so poor that they are practically unusable. So one must develop some asymptotic expressions for the surface fields and up to now these expressions were known only for "good conductors" (V.A. FOCK : *Electromagnetic diffraction and propagation problems*, Pergamon Press, London 1965).

By a careful asymptotic analysis of the exact eigenfunctions solutions we obtained more general asymptotic expressions of the surface fields. To do so we used the uniform asymptotic expansions of the Bessel and Hankel functions due to F.W.J. OLVER and we took advantage of some relatively recent works of this author concerning the "error bounds" (see his excellent book : *Asymptotics and special functions*, Academic Press, N. York 1974).

Our new results for the surface fields apply to dielectrics as well as to conductors, the only requirement being that they are absorbant (P. LANGLOIS and A. BOIVIN : accepted for publication in Canadian Journal of Physics). In the illuminated region we then found again the Fresnel reflexion coefficients, which was to be expected but had not been proved formally. In the transition region from the illuminated face of the cylinder to the other, that is in the so called "penumbral region" we found a generalization of the Fock's integrals for a "good conductor". Finally we also obtained a generalization of the impedance boundary conditions of Leontovich for the "good conductor", which are themselves a generalization of the Dirichlet and Neuman boundary conditions for a perfect conductor.

These new results on the surface fields make it possible to solve the problem of E.M. diffraction by absorbing cylinders (P. LANGLOIS, accepted for publication in *Optica Acta*).

URSI/E-6-1
ELECTROMAGNETIC NOISE AND
INTERFERENCE

104 - AH
Wednesday 1:30 - 4:20

CHAIRMAN: John R. Herman
GTE - Sylvania Systems Group
Westboro, MA 01581

1. (1:30) *AN ADAPTIVE HIGH-DATA-RATE METEORSCATTER COMMUNICATION SYSTEM*, Ashok K. Gupta, The Catholic University of America, Washington, D.C. 20064
2. (1:50) *COMMUNICATION DEGRADATION MODEL FOR POWER LINES*, Daniel N. March, Montana State University, Dept. of Elec. Engr. & Computer Science, Bozeman, MT 59717
3. (2:10) *EFFECTS OF CW INTERFERENCE ON DIRECT SEQUENCE SYSTEMS*, C. P. Tou, Technical Uni. of Nova Scotia, Dept. of Elec. Eng., P.O. Box 1000, Halifax, Nova Scotia, Canada, B3J 2X4
4. (2:30) *MEASUREMENT OF INTERFERENCE TO TELEVISION RECEPTION CAUSED BY AN ARRAY OF LARGE WIND TURBINES*, Dipak L. Sengupta, Joseph E. Ferris, The University of Michigan, Dept. of Elec. & Computer Engr., Ann Arbor, MI 48109
5. (2:50) *POLARIZATION STUDIES IN RADAR HYDROMETEOROLOGY*, Jerald D. Nespor, Naresh C. Mathur, Wolfgang-M. Boerner, University of Illinois at Chicago, Dept. of Elec. Engr. & Computer Science, P.O. Box 4348, Chicago, IL 60680
6. (3:40) *BRIGHTNESS TEMPERATURE OF THE EARTH AS SEEN FROM GEOSTATIONARY ORBIT*, Ernest K. Smith, Eni G. Njoku, California Institute of Technology, Jet Propulsion Laboratory, 4800 Oak Grove Drive, Pasadena, CA 91109
7. (4:00) *ON THE DIURNAL, SEASONAL AND SOLAR CYCLE DEPENDENCE OF THE EFFECT OF THE GEOMAGNETIC ACTIVITY ON THE SCINTILLATION ACTIVITY AT CREST ZONE OF THE APPLETON ANOMALY*, Yinn-Nien Huang, Telecommunication Laboratories, MOC, P.O. Box 71, Chung-Li, Taiwan, ROC

AN ADAPTIVE HIGH-DATA-RATE METEORSCATTER
COMMUNICATION SYSTEM

Ashok K. Gupta
The Catholic University of America
Washington, D.C. 20064

The present paper analyzes an adaptive high-data-rate meteorscatter communication system which maintains a constant data rate over the trail life-time despite time-varying path losses, time varying doppler and multipath spread during this time. For a 4 MHz binary FSK system and error-rate 0.001, it is known (M.D. Grossi and A. Javed, "Time and frequency spread in meteor burst propagation paths," AGARD 1977 paper No. 244) that the data rate decreases from the time of trail's formulation (460 Kbits/sec.) to the end of the trail life-time (46 Kbits/sec.) under the assumed link conditions. The effect of the doppler spread variations is assumed negligible and the multipath spread increases from 0.35 μ sec to 4.5 μ sec, which can be counteracted by increasing the number of frequency diversity from 14 to 18. The channel gain at the end of the trail decreases by about 10 db resulting in a ten-fold decrease in data rate. In the present paper, we propose the use of M-ary codes to remove this limitation of decreasing data rate for fixed transmitted power. Since the data rate for M-ary signalling is $\log_2 M$ times that of binary modulation, variable M-ary signalling can be adopted to counteract the continuous decrease in data rate over the trail life-time. The larger the decrease in data rate, the larger the value of M should be to maintain the constant data rate at a specified performance over the entire trail life. By the use of larger value of M, one can of course increase the instantaneous data rate (more than 460 Kbits/sec.) at the expense of the bandwidth.

Thus the combination of variable M-ary signalling and frequency diversity results in a high-data-rate continuous transmission during the entire trail life of the meteor burst channel. The proposed system is adaptive in the sense that it adapts to time-varying channel parameters. The information about these parameters can be obtained by well-known path sounding and channel probing techniques.

COMMUNICATION DEGRADATION MODEL FOR POWER LINES

Dr. Daniel N. March
Department of Electrical Engineering and Computer Science
Montana State University
Bozeman, MT 59717

A model using graphical techniques has been devised to predict whether electromagnetic communication systems at residences near proposed power line routes will suffer degradation due to interference from the power line if it is built. The model has been used for AM radio, low and high-band TV, UHF TV, and FM radio. The likely electromagnetic noise at a residence versus distance to the line is based on measurements made at residences before and after construction of similar lines. Variations in the data relative to clear field measurements are made. Before predicting degradation the signal and apriori noise levels need to be measured at residences near the line route. This allows a comparison of existing communications quality with that likely after line construction. The quality is quantized into three regions namely, excellent, marginal, and poor, as functions of the signal-to-noise ratio. These quantizations were based on observations at rural residences. The model can be used to predict how far a residence must be from a power line to have a particular quality communication system. This latter mode of operation is advantageous in high population densities. The model has been adopted for several different power line voltages. It accounts for fair weather or inclement weather as well as whether the receiving antenna points at the line or away from it. The model has been used to evaluate communication degradation problems along alternate routes of power lines. These data were a factor in route selection. Several examples of the model and its uses are given.

EFFECTS OF CW INTERFERENCE ON DIRECT SEQUENCE SYSTEMS

C. P. TOU

Department of Electrical Engineering
Technical University of Nova Scotia
Halifax, Nova Scotia, Canada, B3J 2X4

A direct sequence system is a type of spread spectrum communication systems. One of the significant features of the system is its ability to suppress interference and noise, but the system may still be vulnerable to certain types of interference. At first, we might think that a wideband rather than a narrowband interference would be more harmful to the system. This is however not true except the wideband interference has a high cross-correlation with the desired signal. In fact, a continuous-wave (CW) interference can be detrimental to direct sequence systems.

In this paper, we analyze the effects of CW interference on the performance of direct sequence systems to show how the interference affect the systems under certain conditions, and to discuss how to prevent this type of interference from degrading the operation of the systems.

CW interference may be from external sources such as jamming or due to unbalanced spread spectrum modulators in the systems. If the modulator of the transmitter is not well balanced, it would cause incomplete suppression of the code clock and the carrier which are subsequently transmitted as interference. In the receiver, insufficient suppression of the code clock and the carrier by an unbalanced modulator would allow CW interference to leak directly through the correlator and to cause false lock on the phase lock loop of the tracking circuits. Techniques for suppressing CW interference will be discussed based on the result of the analysis.

MEASUREMENT OF INTERFERENCE TO TELEVISION RECEPTION
CAUSED BY AN ARRAY OF LARGE WIND TURBINES

Dipak L. Sengupta and Joseph E. Ferris
Radiation Laboratory
Department of Electrical and Computer Engineering
The University of Michigan
Ann Arbor, Michigan 48109

Electromagnetic interference to television reception caused by an array of three MOD-2 wind turbines (WTs) at Goodnoe Hills, WA, has been studied by carrying out detailed measurements at a number of sites in the vicinity of the WT array. The commercial TV signals available in the region were used as the RF sources during the measurements. At each site, the total received signals (i.e., direct plus scattered off the rotating blades of the WTs) were recorded on a strip chart recorder and the interference effects were observed on the screen of a TV receiver, and, as appropriate, recorded on a video tape.

It has been found that when the blades of different machines do not rotate in synchronism, each WT produces television interference (TVI) effects individually. When the blades rotate in synchronism, they tend to increase the amplitude of the interference pulses thereby producing enhanced TVI effects. The measurement procedure, selected results and their implications will be discussed.

This work was supported by the Wind Systems Branch, Division of Solar Technology, Department of Energy, under Contract SERI-XE-1246-1.

Polarization Studies in Radar Hydrometeorology

Jerald D. Nespor, Naresh C. Mathur and Wolfgang-M. Boerner
Electromagnetic Imaging Division
Communications Laboratory/SEL-4210
Department of Electrical Engineering
& Computer Science/SEO-1141
University of Illinois at Chicago
Box 4348 851 South Morgan St.
Chicago, Illinois 60680

Polarization, along with amplitude, frequency, phase, and doppler, are the five parameters that completely describe an electromagnetic wave. In propagation through anisotropic media, the polarization state can and usually is the parameter most significantly changed. Due to engineering limitations prior to the last decade, such as achieving high polarization purity within an antenna beam, coupled with the lack of theoretical development, polarization diversity techniques applied to radar meteorology have had a low level of research effort.

There has, however, been substantial progress within the last decade with the development of theory for predicting and interpreting backscatter and propagation measurements and with the construction of antennas with good polarization characteristics, as well as fast polarization switching techniques.

As the scope of research relating to polarization has increased, new ideas for meteorological applications have been proposed. It is the expressed objective of this section to review the current research and to suggest a modified approach to polarization diversity techniques which has the possibilities of adding greater insight and reliability to meteorological identification and classification of static and dynamic precipitation states.

BRIGHTNESS TEMPERATURE OF THE EARTH AS SEEN FROM GEOSTATIONARY ORBIT

Ernest K. Smith and Eni G. Njoku
Jet Propulsion Laboratory
California Institute of Technology
4800 Oak Grove Drive
Pasadena, CA 91109, USA

ABSTRACT

It is customary when estimating the antenna noise temperature (Earth coverage beam) of a satellite in geostationary orbit to take the brightness temperature of the Earth to be 290 K (T_0). In fact the brightness temperature may be considerably less than this value. Now that the operating system noise temperatures of satellite receivers are coming down, the value used for antenna noise temperature is no longer of purely academic interest.

This paper represents a collaboration between a propagation worker (E. K. Smith) in the Earth Satellite Communication Group, Telecommunications Systems Section and a researcher in Earth surface sensing (E. G. Njoku) from the Microwave Atmospheric Sciences Section. The problem addressed is to determine \bar{T}_{ap} , the weighted-average apparent temperature of the main beam (3 dB) of a circularly polarized satellite antenna in geostationary orbit with beamwidth 17.43° , for the frequency range 1 to 60 GHz for every 30° in longitude. A radiative transfer code and surface emission code are used to make first-order estimates of land, sea and atmosphere contributions to the main beam apparent noise temperature as a function of angle off boresight, frequency, cloud cover and rain.

The resultant values for \bar{T}_{ap} for the clear atmosphere range from $0.4T_0$ to $0.9T_0$ for moderate surface water vapor. The fact that \bar{T}_{ap} does not exceed $0.9T_0$ even at the peak of the oxygen absorption at 60 GHz is because the weighting function peaks at a level where the atmosphere is cooler. The higher values of temperature obtained for greater concentrations of water vapor and for cloud and rain are due to the higher ambient temperature at the lower altitudes where absorption is taking place.

ON THE DIURNAL, SEASONAL AND SOLAR CYCLE DEPENDENCE OF
THE EFFECT OF THE GEOMAGNETIC ACTIVITY ON THE SCIN-
TILLATION ACTIVITY AT CREST ZONE OF THE APPLETON ANOMALY

Yinn-Nien Huang
Telecommunication Laboratories, MOC
Chung-Li P.O. Box 71, Taiwan, ROC

The ionospheric scintillation observations have been carried out since March 1977 by receiving 136.1124 MHz beacon signal transmitted from ETS-II geostationary satellite at Lunping Observatory. The subionospheric point is located at 23.0°N; 121.9°E geographic coordinate which is at the crest zone of the so called Appleton anomaly of the F2 layer. The scintillation index, SI, proposed by Whitney et al.(1969) was scaled from the chart recording of the received power amplitude, and was used to represent the scintillation activity.

Using the observed scintillation index data from March 1977 to September 1982, the effect of the geomagnetic activity on the scintillation activity was investigated by use of superposed epoch method. In total 51 zero days ($A_p > 30$) were used for analysis. They are further grouped into different seasons and different solar activity (by use of sunspot number, R) to see the dependence of the effect on season and solar activity. The following Table summarizes the results in which N represents no significant geomagnetic effect was found; and Y represents significant geomagnetic effect was found on the day indicated by the number following Y.

The present study shows that the effect of the geomagnetic activity on the scintillation activity seems to depend on local time, season and sunspot number; for instance, during the period for $R > 130$, no significant effect was obtained.

Local Time	00	01	02	03	04	05	06	07	08	09	10	11	12	13	14	15	16	17	18	19	20	21	22	23
R < 70	N	N	N	N	YO	YO	YO	YO	YO	N	N	N	N	N	N	N	N	N	YO	YO	YO	YO	YO	YO
70 < R < 130	Y2	N	N	YO	N	YO	YO	YO	N	Y1	Y1	N	N	N	N	N	N	N	N	N	N	N	Y2	Y2
130 < R	N	N	N	N	N	N	N	N	N	N	N	N	N	N	N	N	N	N	N	N	N	N	N	N
Summer	N	N	N	N	N	N	N	N	N	N	N	N	N	N	N	N	N	N	N	N	N	N	N	N
Equinox	N	N	N	N	N	N	N	N	N	N	N	N	N	N	N	N	N	N	N	N	N	N	N	N
Winter	YO	YO	YO	YO	YO	YO	YO	YO	N	Y1	Y1	N	N	N	N	N	N	N	N	YO	YO	YO	YO	N
All	N	N	N	N	YO	YO	YO	YO	N	N	Y1	N	N	N	N	N	N	N	N	YO	N	N	N	N

URSI/B-7-1
FREQUENCY SELECTIVE SURFACES AND
SYNTHETIC MEDIA

101 - AH
Thursday 8:30 - 11:40

CHAIRMAN: William F. Richards
Department of Electrical Engineering
University of Houston
Houston, TX 77004

1. (8:30) *RESONANT SCATTERING BY SILVER PARTICLES AT OPTICAL FREQUENCIES*, P. W. Barber, Clarkson Col. of Tech., Dept. of Elec. & Comp. Eng., Potsdam, NY 13676, R. K. Chang, Yale Univ., Center for Laser Diagnostics & Section of Applied Physics, New Haven, CO 06520, H. Massoudi, Univ. of Utah, Dept. of Elec. Eng., Salt Lake City, UT 84112
2. (8:50) *AVERAGE DIELECTRIC PROPERTIES OF DISCRETE RANDOM MEDIA USING MULTIPLE SCATTERING THEORY*, V. N. Bringi, J. Vivekanandan, Colo. State Univ., Dept. of Elec. Eng., Fort Collins, CO 80523, V. K. Varadan, V. V. Varadan, Ohio State Univ., Dept. of Engr. Mech., Fort Collins, CO 80523
3. (9:10) *MULTIPLE SCATTERING THEORY FOR WAVES IN DISCRETE RANDOM MEDIA AND COMPARISON WITH EXPERIMENTS*, V. K. Varadan, V. V. Varadan, Ohio State Univ., Dept. of Engr. Mech. & Atmos. Sci., Columbus, OH 43210, V. N. Bringi, Colo. State Univ., Dept. of Elec. Eng., Ft. Collins, CO 80523, A. Ishimaru, Univ. of Wash., Dept. of Elec. Eng., Seattle, WA 98195
4. (9:30) *SCATTERING OF ELECTROMAGNETIC WAVES FROM A HALF-SPACE OF DENSELY DISTRIBUTED DIELECTRIC SCATTERERS*, L. Tsang, Texas A&M Univ., Elec. Eng. Dept., College Station, TX 77843, J. A. Kong, Massachusetts Institute of Technology, Dept. of Elec. Eng. & Comp. Sci., Cambridge, MA 02139
5. (9:50) *ELECTROMAGNETIC DIFFRACTION FROM METALLIC DOUBLY GRATING OF SEMI-SPHERICAL CAVITIES*, J. Dalmaz, R. Deleuil, E. Toro, Universite de Provence, Dept. de Radioelectricite, Marseille, Cedex 13, France
6. (10:40) *ANALYSIS OF FREQUENCY SELECTIVE SURFACES USING THE SPECTRAL ITERATION TECHNIQUE*, J. P. Montgomery, Georgia Institute of Tech., Eng. Exper. Station, Atlanta, GA 30332
7. (11:00) *SCATTERING FROM FREQUENCY SELECTIVE SURFACES AND PERIODIC GRATING OF FINITE EXTENT*, R. Kastner, Israel Armament Devel. Auth., Raj Mitra, University of Illinois, Elec. Eng. Dept., Urbana, IL 61801
8. (11:20) *THE APPLICATION OF THE SPECTRAL-ITERATION APPROACH TO CONDUCTING MESH REFLECTOR SURFACES*, Jerry C. Brand, J. Frank Kauffman, No. Carolina State Uni., Dept. of Elec. Eng. Raleigh, NC 27650

RESONANT SCATTERING BY SILVER PARTICLES AT OPTICAL FREQUENCIES

P. W. Barber
Department of Electrical and Computer Engineering
Clarkson College of Technology
Potsdam, New York 13676

R. K. Chang
Center for Laser Diagnostics and Section of Applied Physics
Yale University
New Haven, Connecticut 06520

and

H. Massoudi
Department of Electrical Engineering
University of Utah
Salt Lake City, Utah 84112

Much of the work in frequency-dependent electromagnetic scattering has been based on the singularity expansion method (C.E. Baum, in Transient Electromagnetic Fields, L.B. Felsen, Ed., Springer-Verlag, Ch. 3, 1976), whereby the natural frequencies of an object are represented by simple poles in the complex-frequency plane. However, the direct interpretation of spectra resulting from real-frequency excitation has also been considered (P.J. Moser, J.D. Murphy, A. Nagl, and H. Überall, Radio Science, 16, 279-288, 1981 and P.W. Barber, J.F. Owen, and R.K. Chang, IEEE Trans. AP, 30, 168-172, 1982). While most of this recent interest has been concerned with target identification, there are other applications of resonant scattering which are equally important. Principal among these is the exploitation of the large electric fields which occur at resonance.

In this paper we describe the tremendous electric field enhancement which can occur at the surface of silver particles when they are illuminated at a frequency corresponding to excitation of the lowest electric dipole resonance. The resulting orders-of-magnitude amplification of the fields has many applications.

The T-matrix method is used to calculate internal, surface, and scattered fields for spherical and prolate spheroidal silver particles. Of particular interest are the electric field surface distributions which show intense polar fields when a prolate spheroidal particle is illuminated by a plane wave polarized parallel to the axis of revolution. Calculated results show that two resonance regimes exist, a high-Q dipole resonance which is strongly dependent on the material properties of silver, and a broader resonance which is based on the usual size/wavelength considerations. Of related interest is the rapid breakdown of the Rayleigh approximation (electrostatic solution) for the highly conducting silver particles.

AVERAGE DIELECTRIC PROPERTIES OF DISCRETE RANDOM MEDIA
USING MULTIPLE SCATTERING THEORY

V. N. Bringi and J. Vivekanandan
Department of Electrical Engineering
Colorado State University
Fort Collins, Colorado

V. K. Varadan and V. V. Varadan
Department of Engineering Mechanics
The Ohio State University
Columbus, Ohio

The objective of this paper is to use rigorous multiple scattering theory for determining the average or bulk dielectric properties of discrete random media. The random medium is modelled as a random distribution of identical, spherical scatterers imbedded in a homogeneous, unbounded, background medium with prescribed first and second order probability distribution functions. As shown previously by Twersky, the form of the radial distribution function becomes very important at high scatterer concentrations. Two models are considered here based on the statistical theory of dense gases, viz., the Virial series and the self-consistent forms. The average loss tangent of the scattering/absorbing medium is computed as a function of frequency and scatterer concentration, and compared with a frequently used mixture formula, e.g., Maxwell-Garnett. Both homogeneous and concentric, layered spherical scatterers are considered. The results show that multiple scattering losses are significant and must be accounted for when $ka \geq 0.05$. The theory and the computational procedure can thus be used as a mixture formula for ka in the range $0 < ka \leq 10$ and concentrations in the range $0 < c \leq 0.4$.

MULTIPLE SCATTERING THEORY FOR WAVES IN DISCRETE RANDOM MEDIA AND
COMPARISON WITH EXPERIMENTS

V.K. Varadan and V.V. Varadan
Boyd Laboratory, Department of Engineering Mechanics and Atmospheric Sciences
The Ohio State University, Columbus, Ohio 43210 USA

V.N. Bringi
Department of Electrical Engineering
Colorado State University, Ft. Collins, Colorado 80523 USA

A. Ishimaru
Department of Electrical Engineering
Washington University, Seattle, Washington 98195 USA

Acoustic and electromagnetic wave attenuation due to multiple scattering in a discrete random two-phase media is studied. A self-consistent multiple scattering theory using the T-matrix of a single scatterer and a suitable averaging technique is employed. The statistical nature of the position of scatterers is accounted for by ensemble averaging. This results in a hierarchy of equations relating the different orders of correlations between the scatterers. Lax's quasi-crystalline approximation is used to truncate the hierarchy enabling passage to a homogeneous continuum whose bulk propagation characteristics such as phase velocity and coherent wave attenuation can then be studied. Special attention is focused on the pair-correlation function between the scatterers using Self-Consistent Approach (SCA) which is found to be superior to Percus-Yevick Approximation (P-YA) when the volume fraction of scatterers becomes significant. Besides deriving low frequency analytical results for coherent wave speed and attenuation, the dispersion equation has been solved numerically for higher frequencies. The numerical results obtained in this study are compared with experimental values, and the agreement is excellent.

SCATTERING OF ELECTROMAGNETIC WAVES FROM A HALF-
SPACE OF DENSELY DISTRIBUTED DIELECTRIC SCATTERERS

- L. Tsang, Electrical Engr. Dept. and Remote Sensing Center,
Texas A&M University, College Station, Texas 77843
- J.A. Kong, Dept. of Electrical Engr. and Computer Science and
Research Laboratory of Electronics, Massachusetts
Institute of Technology, Cambridge, Mass. 02139

There is a growing interest in scattering of waves from geological materials which are characterized by dense distribution of scatterers. For example, dry snow is a mixture of ice and air. The fractional volume of ice in dry snow is between 10% to 40%. An essential feature of a medium with an appreciable fractional volume of scatterers is that independent scattering is no longer true and the radiative transfer theory with independent scattering phase function is not valid. Foldy's approximation, which has been successful in accounting for scattering effects in tenuous media, is also not applicable. In this paper, we consider the scattering of a plane wave obliquely incident on a half space of densely distributed dielectric scatterers. The quasi-crystal-line approximation is applied to truncate the hierarchy of multiple scattering equations and the Percus-Yevick result is used to represent the pair distribution function. The coherent reflected wave is studied with these two approximations. The incoherent scattered wave is calculated with the distorted Born approximation. In the low frequency limit, closed form expressions are obtained for the effective propagation constants, the coherent reflected wave and the bistatic scattering coefficients. Results at higher frequencies are calculated numerically. The advantage of the present approach is that in the low frequency limit, it reproduces the effects of specular reflection, Fresnel reflection coefficient, Brewster angle and Clausius-Mossotti relation. In addition to these classical results, the bistatic scattering coefficients are also calculated. The theory has been successfully applied to match backscattering data from dry snow at microwave frequencies.

ELECTROMAGNETIC DIFFRACTION FROM METALLIC DOUBLY GRATING OF SEMI-SPHERICAL CAVITIES

J. DALMAS, R. DELEUIL and E. TORO

Département de Radioélectricité, Université de Provence, Rue H. Poincaré, 13 397 MARSEILLE, CEDEX 13.

The aim of this paper is to study the diffraction of an electromagnetic plane wave from a doubly periodic perfectly conducting grating, assumed to be infinitely extended. This grating is made of semi-spherical cavities periodically distributed along two perpendicular axis.

The field within the semi-spherical cavity regions is described with the help of the Debye potentials and expanded in terms of eigenfunctions of the spherical coordinate system. This field must satisfy the boundary conditions at the perfectly conducting semi-spherical surface. The total electric field in the free-space region (I) above the doubly grating surface may be expressed as the sum of an incident plane wave and an infinite series of outgoing plane waves (Rayleigh expansion). The different components of the fields (incident and diffracted) are given by means of the Bromwich potentials. The continuity of the fields at the fictitious boundary F between the (I) and (II) regions is obtained by writing the continuity of the tangential components of the electric fields and their normal derivatives. The continuity of these tangential components on the perfectly conducting plane surface P is expressed, too.

A numerical implementation of the theory is realized. It must be noted that a possible expansion of this theory is to consider a doubly grating of semi-prolate spheroidal cavities which are well adapted to the study of a class of solar selective structures.

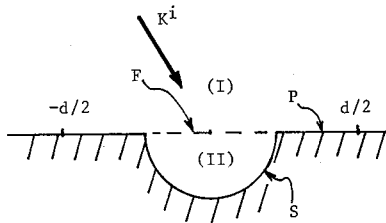

ANALYSIS OF FREQUENCY SELECTIVE SURFACES
USING THE SPECTRAL ITERATION TECHNIQUE

J. P. Montgomery
Georgia Institute of Technology
Engineering Experiment Station

The spectral iteration technique has recently been applied to the solution of frequency selective surfaces (C. H. Tsao and R. Mittra, IEEE Trans. on Antennas and Propagat., March 1982, pp. 303-308). The purpose of this paper is to critically discuss the convergence of the spectral iteration technique. In fact, the algorithm published will fail to converge in some cases. However, the variational factor can be changed to a current base rather than an electric field base and convergence restored. Special attention is placed on the convergence of the inductive reactance and capacitance susceptance (both with and without a dielectric substrate) of an array of thin strips. A comparison with exact results obtained via the Wiener Hopf method shows that the solution generally converges very uniformly. However, the number of terms must generally be greater than 128 for an accuracy of $\pm 5\%$. Better accuracy can be obtained by extrapolation. The technique has also been extended to periodic elements obeying an impedance boundary condition.

SCATTERING FROM FREQUENCY SELECTIVE SURFACES
AND PERIODIC GRATINGS OF FINITE EXTENT

R. Kastner
RAFAEL
Israel Armament Development
Authority

R. Mittra
Electrical Engineering Dept.
University of Illinois
Urbana, Illinois

Conventionally, frequency selective surfaces and other periodic gratings, e.g., aperture arrays, are analyzed using the assumption that they are infinite in extent, although clearly the dimensions of practical FSS and array structures are necessarily finite. A number of methods, e.g., mode matching, moment method, and spectral-Galerkin approach, are available for analyzing infinite periodic structures. All of these methods are based on a Floquet-type representation of the fields in a unit cell, whose dimensions are typically on the order of a wavelength. However, none of these techniques allow convenient extension to the more practical geometry which has a large, but finite, number of array cells. However, an alternative approach, called the Spectral-Iterative Technique (SIT), has been found suitable for analyzing periodic as well as isolated scatterers [Ko and Mittra, *IEEE Trans. on Antennas & Propagation*, 25, 187-197, 1977; Tsao and Mittra; *ibid.*, 30, 303-308, 1982, and Kastner and Mittra, *ibid.* (to be published)] and is eminently suited for analyzing a finite grating. The infinite grating solution can be employed as a convenient starting point for the iteration procedure, although this is not necessary, and almost any zero-order solution can be employed for this purpose. The edge effects caused by the truncation of an infinite grating are easily delineated in the SIT approach which yields the periodic field distribution in the entire finite-sized structure.

To illustrate the application of SIT to finite-sized gratings, an array of $0.2\lambda \times 0.2\lambda$ square metallic patches in a $0.4\lambda \times 0.4\lambda$ cell was analyzed for the case of normal incidence and for both the x- and y-polarized cases. It is assumed that the FSS structure has six cells in the x-direction, whereas it is infinite in the y-direction. J_x and J_y , the two components of the current on the patches, were computed for all patches, and the differences between the center and edge cells were clearly evident from these computations.

The built-in boundary condition check in the SIT method guarantees the accuracy of the solution once the convergence is achieved. The method presented is very general and is expected to find wide applications to other scattering problems of practical interest.

THE APPLICATION OF THE SPECTRAL-ITERATION APPROACH
TO CONDUCTING MESH REFLECTOR SURFACES

Jerry C. Brand and J. Frank Kauffman
North Carolina State University
Raleigh, NC 27650

Knitted mesh surfaces currently in use for reflectors on space deployable antennas are not solid and continuous but are perforated and periodic. This type of surface exhibits reflection characteristics which are frequency dependent and, as such, must be carefully analyzed. The analysis could be formulated in terms of classical integral equations or the Method of Moments, but particular problems arise which prevent the development of a convenient solution algorithm. However, the periodic nature of the mesh surface allows the application of a novel technique to the problem (C.H. Tsao and R. Mittra, IEEE AP-30, No. 2, p. 303-308, 1982).

This technique, the spectral-iteration approach, utilizes the periodic nature of the mesh to construct a possible solution for determining reflection characteristics of the surface using Floquet's theorem, the Discrete Fourier Transform (DFT), and a variational expression. The result is an iterative solution process which can be applied to mesh structures. A test case using infinite length parallel wires is chosen since the scattering solutions are well documented. The results indicate that convergence can only be guaranteed when the wire separation is a large portion of a wavelength unless special precautionary steps are taken. These steps include initializing the process with a more suitable trial field, smoothing the corrective variational expression and filtering the non-contributing Floquet modes. Results of these procedures are presented and their applicability to the mesh problem discussed. The reflection characteristics of a typical mesh surface are explored and several problems that arise when applying this technique to various mesh surfaces are addressed.

URSI/B-7-2
ELECTROMAGNETIC THEORY

Auditorium 2 - AH
Thursday 8:30 - 11:40

CHAIRMAN: P. L. E. Uslenghi
Department of Electrical Engineering
University of Illinois at Chicago
Chicago, IL 60680

1. (8:30) *REFLECTIONS ON LAUNCHING FOCUS WAVE MODES FROM CLASSICAL ANTENNAS*, James Neill Brittingham, Lawrence Livermore National Lab, P.O. Box 5504, L-156, Livermore, CA 94550
2. (8:50) *A DOUBLE-VARIATIONAL METHOD FOR COMPUTING THE END EFFECTS OF ANTENNAS AND TRANSMISSION LINES*, David C. Chang, Edward F. Kuester, University of Colorado, Dept. of Electrical Engineering, Boulder, CO 80509
3. (9:10) *FORMULATION OF THE ELECTROMAGNETIC SCATTERING BY A RESISTIVE WEDGE USING THE KONTOROVICH-LEBEDEV TRANSFORM*, Ivan J. Lefkovic, ERM, Infrared & Optics Division, P. O. Box 8618, Ann Arbor, MI 48107
4. (9:30) *INHOMOGENEOUS PLANE WAVES: REFLECTION AND REFRACTION AT A LOSSY DIELECTRIC INTERFACE*, P. L. Overfelt, D. J. White, Naval Weapons Center, Michelson Laboratory, Code 3814, China Lake, CA 93555
5. (9:50) *TRANSIENT PROPAGATION AND SCATTERING IN THE WEAKLY DISPERSIVE REGIME*, L. B. Felsen, E. Heyman, Polytechnic Institute of New York, Dept. of Elec. Engr. & Computer Science, Route 110, Farmingdale, NY 11755
6. (10:40) *SOME RESULTS OF THE WIGNER-DISTRIBUTION MATRIX FORMULATION FOR THE ELECTRIC FIELD IN A STOCHASTIC DIELECTRIC*, Dimitri S. Bugnolo, Florida Institute of Technology, Dept. of Electrical & Computer Eng., Melbourne, FL 32901
7. (11:00) *WELL POSED SPECTRAL MODELS FOR DIELECTRIC FLUCTUATIONS*, Dimitri S. Bugnolo, Florida Institute of Technology, Dept. of Electrical & Computer Eng., Melbourne, FL 32901
8. (11:20) *CERENKOV PHENOMENON VIEWED AS AN ELECTROSTATIC PROBLEM IN A MOVING MEDIUM*, C. T. Tai, University of Michigan, Dept. of Electrical & Computer Eng., Ann Arbor, MI 48109

REFLECTIONS ON LAUNCHING FOCUS WAVE MODES FROM
CLASSICAL ANTENNAS*

James Neill Brittingham, PhD
Lawrence Livermore National Laboratory
Livermore, CA 94550

At a recent meeting a paper [Focus Wave Modes in Homogeneous Maxwell's Equations - TE Modes, J. N. Brittingham, 1982 International Symposium Digest Antennas and Propagation, Vol. 2, pp. 656-659, Albuquerque, New Mexico] containing new, unique mathematical solutions to Maxwell's equations was presented. These solutions represent three-dimensional, nondispersive, source-free electromagnetic pulses which propagate in free space. The pulses propagate in a straight line at light-velocity. The pulses' amplitudes decrease in front of, behind, and transverse to the axis of propagation. Besides the pulses being nondispersive, they retain the identical pulses' shapes for all time as they propagate through space. It is this focusing of the pulses which gives them the name Focus Wave Modes [abbreviated FWM]. The far-field amplitude away from the moving pulse-centers decrease as the inverse of the distance from the pulse-centers. It is natural to question how might such electromagnetic pulses be launched. This paper presents some ideas on this topic.

Since an antenna is generally some surface on which electrical currents are given this study begins by specifying an antenna surface. The antenna surface chosen here is a plane which is perpendicular to the axis of propagation. This antenna plane is assumed to be fixed in space with time varying electrical currents. To find the antenna currents which might launch the FWM into free space a method similar to the procedure outlined by Harrington [Time-Harmonic Electromagnetic Fields, R. F. Harrington, McGraw-Hill, 1961, pp. 110-111] is used. In this approach the equivalence theory and image principle are used to obtain equivalent electrical currents on the plane which excite the FWM fields into space. The currents' pulse functions are described by the magnetic fields tangential to the antenna plane. On investigation these pulse functions are found to be composed of simple functional parts with each one of these parts simple enough to be generated by present-day circuitry. There are a few drawbacks with this approach in launching of the FWM fields. One is that to launch such a pulse which would propagate forever would require a current source at each point on the antenna surface. But, if one is interested in launching pulses which will stay focused for some finite distance and then disperse, there is hope of using such an antenna for limited distances. Future engineering studies are needed to find how well these finite element antennas might perform. There is another problem associated with the present FWM mathematical formulations. Even though the pulse functions are three-dimensional, they have an infinite electromagnetic energy associated with them. In the future more research is needed to find FWM solutions which have finite electromagnetic energy. Admittedly there are many voids in the present technology necessary to launch such electromagnetic pulses, but the exciting prospect of being able to launch such pulses makes this a compelling new research area. This paper is presented hoping to generate interest in this new area.

A DOUBLE-VARIATIONAL METHOD FOR COMPUTING THE
END EFFECTS OF ANTENNAS AND TRANSMISSION LINES

David C. Chang and Edward F. Kuester,
Electromagnetics Laboratory, Department of
Electrical Engineering, Campus Box 425
University of Colorado, Boulder, CO 80309

L.A. Vainshtein (Sov. Phys. Tech. Phys., 6, 19-29, 1961) introduced a novel "double-variational" functional which he used to calculate the impedance of a cylindrical linear antenna. Unlike conventional scalar stationary functionals, Vainshtein's expression contains two distinct trial functions, and is stationary with respect to both. Vainshtein's functional has more recently been used by Shameeva (Radio Eng. Electron. Phys., 15, 240-249, 1970; 16, 745-755, 1971; 22 (10), 135-137, 1977) and her colleagues to calculate the reflection and transmission coefficients for the current at an open circuit and at a bend in a two-wire transmission line. Unfortunately, a kind of ad hoc assumption is made in this work about the form of the reflected current waves, (one which is not ameliorated by the variational property), and it is not clear how the method could be used in a more general situation.

In this paper, we will present a modified form of Vainshtein's functional which does not require any assumption about the form of the reflected current (other than as it is used as a trial function), but yields a refined expression for this current along with an approximate form for the reflection coefficient when a very simple trial current distribution is assumed. This functional is complementary to Vainshtein's, in that it is not naturally suited to the calculation of transmitted current distributions, while Vainshtein's requires no ad hoc assumptions to deal with these.

The modified stationary functional will be used to calculate the reflection coefficient from the end of a linear antenna, from the end of a coaxial transmission line joined to a circular waveguide, and from a truncated microstrip transmission line. This reflection coefficient shows both the effects of the power radiated from the open-ended strip, as well as capacitive effects due to quasistatic fringing fields near the end of the strip. Our results will be compared with others available in the literature.

FORMULATION OF THE ELECTROMAGNETIC SCATTERING
BY A RESISTIVE WEDGE USING THE KONTOROVICH-LEBEDEV TRANSFORM

Ivan J. LaHaie
Infrared and Optics Division
Environmental Research Institute of Michigan
P.O. Box 8618
Ann Arbor, Michigan 48107

The electromagnetic scattering of an E- and H-polarized plane wave normally incident upon a resistive wedge is formulated using the Kontorovich-Lebedev (K-L) transform. By decomposing the fields into components which are symmetric and antisymmetric about the bisector of the wedge, the transformed resistive boundary conditions lead to four uncoupled functional equations for the four transformed unknowns (two for each polarization). By restricting the included angle of the wedge, the functional equations can be expressed in two forms: as linear, second order difference equations with variable coefficients, or, by applying a technique developed by the author, as Fredholm integral equations of the second kind over the Banach space of uniformly bounded, continuous functions on a semi-infinite line. The former are not amenable to solution using standard techniques, but the latter admit a uniformly convergent Neumann series expansion in powers of $1/\eta$ for E-polarization, and in powers of η for H-polarization, where η is the normalized resistivity. Bounds for the radii of convergence of the series are developed which are functions of the included angle of the wedge. Within the bounds developed, there are no values of η for which the series converge simultaneously for both polarizations, and hence the results cannot be justifiably applied to an arbitrarily polarized incident plane wave.

INHOMOGENEOUS PLANE WAVES: REFLECTION AND REFRACTION
AT A LOSSY DIELECTRIC INTERFACE

P. L. Overfelt and D. J. White
Michelson Laboratory, Physics Division
Naval Weapons Center, China Lake, California 93555

Inhomogeneous plane waves are waves of the form $e^{i\vec{k}\cdot\vec{r}}$, where \vec{k} is the complex propagation vector, $\vec{k} = \vec{k}_r + i\vec{k}_i$. They are the general representation of the more commonly used homogeneous plane waves of the same form where $\vec{k}_r \times \vec{k}_i = 0$, i.e., \vec{k}_r and \vec{k}_i are colinear. Physically, the two wave forms are differentiated by the fact that, in the homogeneous case, the surfaces of constant phase and amplitude coincide; for inhomogeneous waves, they are oriented at some arbitrary angle to one another. The problem of reflection and refraction of an inhomogeneous plane wave at an interface between vacuum and a lossy medium has been approached in various ways, notably via the standard Snell's law formulation (J.S. Stratton, Electromagnetic Theory, McGraw-Hill, 1941; M. Born and E. Wolf, Principles of Optics, Pergamon, 1964). However, it has not been treated in an explicit and comprehensive manner. In addition, the problem of reflection and refraction of an inhomogeneous plane wave at an interface between two lossy media has received little formal attention.

This presentation addresses both of the above problems. The explicit reflected and transmitted electric and magnetic fields are found by solving the wave equation, assuming an inhomogeneous plane wave form of solution and applying the appropriate boundary conditions. The reflection and transmission coefficients developed from this approach are seen to agree with previous methods. A complex form of Snell's law is used to indicate the relationship between the complex angle of refraction, the complex angle of incidence, and the material parameters of both media. Applications of inhomogeneous plane waves to both lossless media ($\vec{k}_r \cdot \vec{k}_i = 0$), involving the mechanism of total internal reflection, and lossy media ($\vec{k}_r \cdot \vec{k}_i \neq 0$) under various restrictions are discussed.

TRANSIENT PROPAGATION AND SCATTERING IN THE WEAKLY DISPERSIVE REGIME

by

L.B. Felsen and E. Heyman

Department of Electrical Engineering and Computer Science/Microwave Research Institute
Polytechnic Institute of New York
Farmingdale, NY 11735

Wave processes in physical homogeneous bulk media usually exhibit properties of dispersion, which imply that the wavenumber $k(\omega)$ of a plane wave is a non-linear function of frequency. Even in non-dispersive bulk media, the presence of inhomogeneities or boundaries may affect certain wave types in a dispersive manner. However, these dispersive phenomena are weak at sufficiently high frequencies. Propagation in an inhomogeneous environment or along curved boundaries may then be expressed in terms of local plane waves without dispersion. When these local plane waves are used to synthesize an impulsive response, they yield a Cagniard-deHoop type transient field in closed form. The resulting expression is valid for a certain time interval following the arrival of the wavefront at the observer. For impulsive point or line sources in the presence of a plane boundary separating two different homogeneous non-dispersive half spaces, the Cagniard-deHoop solution, including the lateral wave, is known to be exact for all time. For inhomogeneous media or surface fields on convex objects, the solution is more restricted. The presentation deals with this class of phenomena in a unified manner, basing the validity of Cagniard-deHoop type results on the extent to which dispersion can be neglected in the relevant wave processes. In particular, it is shown that clusters of dispersive creeping waves behave like a non-dispersive lateral wave field near the wavefront traveling around a smooth scatterer. Some observations are made about dispersive corrections.

SOME RESULTS OF THE WIGNER-DISTRIBUTION MATRIX FORMULATION FOR THE
ELECTRIC FIELD IN A STOCHASTIC DIELECTRIC

Dimitri S. Bugnolo

Florida Institute of Technology
Melbourne, Florida

In a recent work (D.S. Bugnolo & H. Bremmer, In: Vol. 61, "Advances in Electronics and Electron Physics," Academic Press 1983.), the Wigner-distribution matrix formulation has been used to derive a set of transport equations for the tensor Wigner function in a time-variable, anisotropic stochastic dielectric.

In this paper we present some of the results of a computer simulation of the approximate transport equation for the principal component of the matrix, in a time-invariant, isotropic dielectric. This simulation addresses the problem of propagation in the 1 cm to 1 mm wavelength region.

WELL POSED SPECTRAL MODELS FOR DIELECTRIC FLUCTUATIONS

Dimitri S. Bugnolo

Florida Institute of Technology
Melbourne, Florida

The Fourier transform relating the space time correlation function and the spectrum of a time-variable stochastic dielectric is given by:

$$h_{ik}(\vec{a}, \tau) = \int d\vec{k}' d\omega' \mathcal{E}^{-i(\vec{k}' \cdot \vec{a} + \omega' \tau)} P_{ik}(k', \omega')$$

A given spectral form will be said to be 'well posed', if the integrals in the limit as $\vec{a} \rightarrow 0$, $\tau \rightarrow 0$, yields the mean squared value for the fluctuations, $\langle \mathcal{E}^2 \rangle$.

In this paper we exam a few of the more common spectral forms in the literature. We find that while the Norton class of functions are indeed 'well posed', the van-Karman function is not. We conclude that the class of van-Karman functions for the space-wise spectrum are only 'well posed' in the limit where the inner scale size goes to zero, or where $K_m \gg K_0$, where K_0 is the wavenumber associated with the outer scale.

We shall also present some computer results of the error associated with 'ill posed' spectral forms.

CERENKOV PHENOMENON VIEWED AS AN
ELECTROSTATIC PROBLEM IN A MOVING MEDIUM

C. T. Tai
Radiation Laboratory
Department of Electrical and Computer Engineering
University of Michigan
Ann Arbor, Michigan 48109

Abstract

The theory of Cerenkov radiation was developed by Frank and Tamm (Doklady An SSSR, 14, 107, 1937) as an electrodynamic problem of a moving charge in a material medium with a speed greater than that of the speed of light in the medium. Nag and Sayied (Proc. of Royal Soc. A235, 544, 1956) treated the same problem by considering it as an electrostatic problem of a charge placed in a moving medium. They used Minkowski's original constitutive relations for a moving medium as the foundation of their theory. In the present work we have adopted the same point of view but have simplified the treatment by introducing the proper steady-state vector potential and scalar potentials to facilitate the formulation of the problem. Minkowski's relations have also been reduced to a more attractive form to enhance the description of the gauge condition between the potential functions. The formulation is first applied to a static charge in a moving lossless isotropic medium. It is then extended to a lossy moving medium. Cerenkov phenomenon in a circular waveguide is investigated for a static charge and for an oscillating dipole. Some of the unfamiliar aspects of the fields in this class of problems will be pointed out.

URSI/B-8-1
MEASUREMENTS

Auditorium 1 - AH
Thursday 1:30 - 2:50

CHAIRMAN: L. Wilson Pearson
Department of Electrical Engineering
University of Mississippi
University, MS 38677

1. (1:30) *AN INFRARED INVESTIGATION OF SURFACE CURRENTS ON METAL PLATES*, R. M. Sega, M. H. Hellbusch, J. P. Jackson, R. W. Burton, University of Colorado, Colorado Springs, Dept. of Electrical Engineering, Colorado Springs, CO 80933, V. M. Martin, U.S. Air Force Academy, Dept. of Physics, CO 80840
2. (1:50) *DETERMINATION OF MICROWAVE INDUCED RESONANT PATTERNS IN SYMMETRICAL TARGETS BY INFRARED DETECTION OF JOULE HEATING*, J. P. Jackson, D. A. Kelly, R. M. Sega, R. W. Burton, University of Colorado, Colorado Springs, Dept. of Electrical Engineering, Colorado Springs, CO 80933
3. (2:10) *A DUAL POLARIZED 35 GHZ FMCW MEASUREMENT RADAR*, R. M. Barnes, G. M. Vachula, Sperry Research Center, 100 North Road, Sudbury, MA 01776
4. (2:30) *STATISTICAL DISTRIBUTION OF RELAXATION TIMES FOR OIL SHALE DIELECTRIC*, R. S. Kasevich, Raytheon Company, Equipment Division / MS 4-1-157, 528 Boston Post Road, Sudbury, MA 01776

AN INFRARED INVESTIGATION OF SURFACE CURRENTS
ON METAL PLATES

R.M. Sega, M.H. Hellbusch, J.P. Jackson, R.W. Burton
Department of Electrical Engineering
University of Colorado, Colorado Springs
Colorado Springs, Colorado 80933

V.M. Martin
Department of Physics
U.S. Air Force Academy, CO 80840

An infrared measurement technique for determining the magnitude of surface currents has been extended to metal plates of several wavelengths in size and the signal to noise ratio increased through image processing and elevation of incident microwave power density. A comparison is made with magnetic field probe measurements and theoretical solutions for metallic flat plates illuminated with a normally incident, plane electromagnetic wave.

Coatings are used as "transducers" such that energy is deposited in the coating as a function of the resultant electric field and will manifest itself as a temperature increase on the coating surface. A field probe is used to correlate current measurements obtained by detection of surface fields with measurements obtained by thermal patterns and to investigate the fields present at the conductive/emissive coating location both with and without the coating on the metal target.

Targets of larger electrical size with correspondingly more complex patterns are studied without sacrificing IR resolution. The infrared signal to noise is increased with image processing techniques and related to current values. This study of infrared obtained surface current amplitude distributions compared with electromagnetic computer code calculations and probe measurements on flat plates is an essential step toward the infrared measurement of current distributions on more complex shapes.

DETERMINATION OF MICROWAVE INDUCED RESONANT PATTERNS
IN SYMMETRICAL TARGETS BY INFRARED DETECTION OF JOULE HEATING

J.P. Jackson, D.A. Kelly, R.M. Sega, R.W. Burton
Department of Electrical Engineering
University of Colorado, Colorado Springs,
Colorado Springs, Colorado 80933

Consider a plane microwave incident on a target of uniform composition. Depending on the conductivity of the target, wavelength, and target geometry, resonant current patterns can be set up. These patterns give rise to associated joule heating by which they can be observed directly by an infrared thermovision camera. We have studied target configurations in which all the above variables were held constant except for conductivity. We show by infrared photographs that as conductivity is varied so does resonant pattern structure. We then compare these observations with theoretical predictions for flat plates and spheres.

A typical example of a resonant pattern on a 2λ plate at 3.0 GHz is shown in Figure 1. Bright areas correspond to increased joule heating.

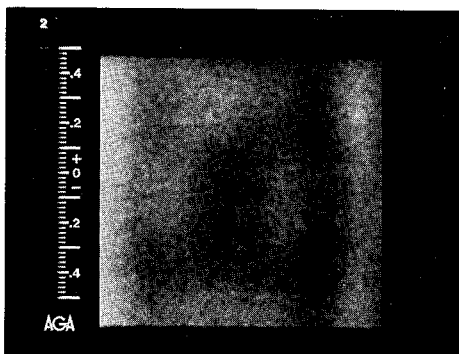

Figure 1

A DUAL POLARIZED 35 GHz FMCW MEASUREMENT RADAR

R.M. Barnes and G.M. Vachula
Sperry Research Center
100 North Road
Sudbury, MA 01776

Polarization null/maxima measurements have been made on a set of generic targets using a testbed dual polarized millimeter radar designed and built specifically for polarization-based target discrimination algorithm development. The radar is a 35 GHz frequency modulated continuous wave (FMCW) system with a single range gate. It has 20 dBm average power, 2° antenna beamwidth, and a 500 MHz electronically tunable bandwidth (and was configured as a constant frequency system for these null measurements). The radar was real-time computer controlled in transmit polarization; on receive, real-time Stokes parameters were output from the dual-polarized IF/video subsystem.

Both resonance-region and geometric-optics region measurements can be taken with this testbed radar using an outdoor measurement range with the target mounted on a two meter-high polyfoam support pylon at a range from the radar of 20 to 100 meters. The support pylon was rotated on a ground level turntable including a digital shaft encoder for aspect angle data logging. Backscatter from the turntable and the bottom of the pylon were minimized by use of a radar fence located halfway between the radar and the target.

For each data run, the target elevation angle was fixed and a slow turn on the turntable commenced. At each aspect, Stokes parameters were measured, averaged to reduce receiver noise effects, and recorded on floppy diskette, along with calibration and ancillary information. These data were read into the Sperry Research Center Univac 1106 computer, in which Stokes vectors were mapped into null polarizations to be used as input for other data analysis. The set of co-polarized and cross-polarized nulls (together with scattering amplitude) maps uniquely into the relative phase polarization scattering matrix, which in turn (for the monochromatic case) can be determined using Stokes vectors measured with orthogonal transmit polarization pairs.

STATISTICAL DISTRIBUTION
OF RELAXATION TIMES FOR
OIL SHALE DIELECTRIC

BY

R. S. KASEVICH

ABSTRACT

Radio frequency methods have been proposed for assaying oil shale deposits and as a diagnostic tool during in-situ processing. Specifically, Judzis has shown that a correlation exists between shale richness and dielectric loss tangent at 500 MHz and 24° but no discernible relationship between ϵ' and oil shale richness between 10^7 and 10^9 hertz. (R. Nottenburg, et al, *Thermochimica*, 31, 39-46, 1979).

Analysis of measured complex dielectric constants of oil shale has shown that by characterizing the oil shale radio frequency absorption mechanism as a distribution of relaxation times and assuming this distribution is statistical in nature, a remarkably accurate theoretical description of the experimental data is obtained. The possibility of using a statistical distribution of relaxation times was indicated by making a rough comparison between the structures of the molecular complexes found in cable insulating oils and kerogen in oil shale. (R. M. Hakim, *IEEE Trans. Elec. Insul.*, E16, 4, 158-164, 1971.) The particular group or groups of polar molecules which give rise to a dipole relaxation mechanism in these oils is not yet determined, but the benzene ring structure could lead to a charge unbalance and dipole formation giving rise to a relaxation mechanism. Application of radio frequency electric fields will change the angular direction of dipoles by jumping over one or more potential energy barriers. The relaxation time is, therefore, controlled by the probability of jumping over the potential energy barriers which are dependent on the local molecular arrangement and interaction, as well as the shape of the individual molecules. Using Wagner's theory describing a statistical distribution of relaxation times according to the law that the logarithms of the relaxation times of the various molecular groups are grouped about the logarithm of the most prominent relaxation term τ_0 , excellent agreement with experimental data has been obtained. (W. A. Yager, *Physics*, 7, 434-450, 1936.)

AUTHOR INDEX

Author	page	Author	page
Auton, J, R.....	12, 14	Eftimiu, C.....	17, 68
Aydin, K.....	88	Eom, H, J.....	74, 75
Bahar, E.....	37, 38	Evell, G, W.....	35
Balling, P.....	27	Farhat, N, H.....	70
Barber, P, W.....	130	Fathy, A, E.....	96
Barnes, R, M.....	150	Felsen, L, B.....	91, 143
Barrick, D, E.....	37, 38	Ferris, J, E.....	125
Blanchard, A, J.....	73	Fessenden, D, E.....	45
Blau, R.....	93	Fischer, M.....	61
Boerner, W.....	62, 63, 65, 126	Fitzwater, M, A.....	38
Boivin, A.....	120	Flanagan, P, W.....	114
Bolomey, J, C.....	72	Fung, A, K.....	74, 75
Bondyopadhyay, P, K.....	19	Galindo-Israel, V.....	26
Borden, B.....	67	Ge, D, B.....	70
Borgiotti, G, V.....	6	Goodman, D, M.....	13
Brand, J, C.....	137	Gould, K, L.....	91
Bringi, V, N.....	88, 131, 132	Graglia, R, D.....	115, 116
Brittingham, J, N.....	139	Gupta, A, K.....	101, 122
Brown, A, C, Jr.....	56	Gurrola, E, M.....	99
Bruce, R, L.....	26	Hanson, D, F.....	43
Bruck, D.....	61	Harker, K, J.....	44
Bugnolo, D, S.....	144, 145	Hellbusch, M, H.....	148
Burke, G, J.....	46	Hessel, A.....	96
Burns, M.....	64	Heyman, E.....	143
Burton, R, W.....	148, 149	Hoofar, A.....	18
Butler, C, M.....	3, 4, 43	Huang, Y.....	128
Carl, J, R.....	97	Huddleston, P, L.....	17
Chang, D, C.....	18, 140	Hung, C, C.....	25
Chang, D, C, D.....	24	Hurst, M.....	87
Chang, R, K.....	130	Imbriale, W, A.....	26
Chen, K.....	112	Ingram, J, D.....	91
Cheng, D, H, S.....	10	Ishimaru, A.....	31, 132
Cheo, A.....	33	Izadian, J, S.....	40
Chow, Y, L.....	110	Jackson, J, P.....	148, 149
Chu, T, H.....	70	Jaggard, D.....	70
Chuang, H.....	112	Jofre, L.....	72
Coblin, R, D.....	51	Jorgensen, R.....	27
Dahleh, M.....	86	Kahn, W, K.....	105
Dalmas, J.....	134	Kasevich, R, S.....	100, 151
Damaskos, N, J.....	108	Kastner, R.....	136
Daniele, V, G.....	118	Kauffman, J, F.....	137
Davis, W, A.....	90	Kaupp, V, H.....	76, 77, 78
Deleuil, R.....	54, 134	Kelly, D, A.....	149
DiFonzo, D, F.....	22	Kim, C, S.....	55
Duchene, B.....	60	Kim, T, J.....	53
Dudley, D, G.....	13, 15	King, R, W.....	76
Dunbar, B, J.....	91	Knepp, D, L.....	30
		Kong, J, A.....	133

Author	page
Kuester, E, F.....	140
Kumar, P, N.....	29
LaHaie, I, J.....	141
Lang, K, C.....	24
Lang, R, H.....	32
Langenberg, K, J.....	61
Langlois, P.....	54, 120
Lee, B, S.....	22
Lee, C, Q.....	64
Lee, H.....	84
Lee, S, W.....	8
Lennon, J, F.....	36
Lewton, W, A.....	97
Lin, J.....	119
Lindell, I, V.....	106
Ling, H.....	8
Lo, Y, T.....	81, 83, 98
Loomis, J, M.....	95
Luh, H.....	23
MacDonald, H, C.....	76, 77, 78
Mack, R, B.....	108
Maffett, A, L.....	108
Manara, G.....	2
Mankoff, S.....	70
March, D, N.....	123
Martin, V, M.....	148
Massoudi, H.....	130
Mathur, N, C.....	126
Matthews, E, W.....	23
Matthews, N, D.....	77
Medgyesi-Mitschang.....	52
Michalski, K, A.....	4
Miller, E, K.....	46
Mirmira, V, K, S.....	63
Mittra, R.....	9, 25, 41, 42, 87, 136
Montgomery, J, P.....	135
Morgan, M, A.....	12, 16
Nespor, J, D.....	126
Nevels, R.....	80, 86
Njoku, E, G.....	127
O'Brien, M.....	94
Odom, D, B.....	100
Oksanen, M, I.....	106
Oliner, A, A.....	103
Olsen, R, G.....	109
Overfelt, P, L.....	142
Jverly, M.....	80
Papa, R, J.....	36
Parmon, W.....	108
Pathak, P, H.....	50

Author	page
Pearson, L, W.....	51
Pelosi, G.....	2
Peng, S, T.....	33, 103, 104
Peronnet, G.....	72
Pichot, C.....	60
Pisaruck, M, A.....	78
Post, R, E.....	71
Qiu, Y.....	57, 58
Rahmat-Samii, Y.....	21, 26
Rao, S, M.....	89
Richards, W, F.....	81, 82, 83, 98
Ritt, R, K.....	113
Roberts, T.....	23
Rojas-Teran, R.....	50
Rose, J, F.....	95
Sarkar, T, K.....	47, 48
Schneider, A.....	32
Schwering, F.....	104
Scott, W, G.....	23
Sega, R, M.....	148, 149
Seker, S.....	32
Seliga, T, A.....	88
Sengupta, D, L.....	125
Senior, T, B, A.....	117
Shegetti, R.....	64
Shen, M.....	58
Sheshadri, M, S.....	9
Shiau, M, J.....	103
Shigesawa, H.....	107
Shore, R.....	94
Simon, J.....	15
Singh, S.....	81, 82
Skupien, C, E.....	98
Smith, E, K.....	127
Smith, G, S.....	7
Smoll, A.....	23
Steyskal, H.....	94
Stone, W, R.....	66
Sultan, M, F.....	41, 42
Tabbara, W.....	60
Taflove, A.....	89
Tai, C, T.....	146
Taylor, R, L.....	36
Tew, M, D.....	55
Throne, R, D.....	100
Tiberio, R.....	2
Toro, E.....	134
Tou, C, P.....	124
Tran, H, B.....	53
Tsang, L.....	86, 133

Author	page
Tsuji, M.....	107
Tutt, M, N.....	110
Umashankar, K.....	89
Uslenghi, P, L, E.....	108, 115, 116, 118
Vachula, G, M.....	150
Van Blaricum, M, L.....	12
Varadan, V, K.....	131, 132
Varadan, V, V.....	131, 132
Vivekanandan, J.....	131
Wait, J, R.....	5, 114
Waite, W, P.....	76, 77, 78
Wang, D, Y.....	52
Weyker, R.....	15
White, D, J.....	142
Williams, J, T.....	5
Wilton, D, R.....	81, 82
Wolkoff, E, A.....	10
Wright, S.....	81, 83
Xu, X.....	3
Yang, C.....	65
Yeh, C.....	31
Zhong, S, S.....	98
Zhu, S.....	112
Zinecker, J, R.....	81, 83

